



SPACE POLICE

5984



1

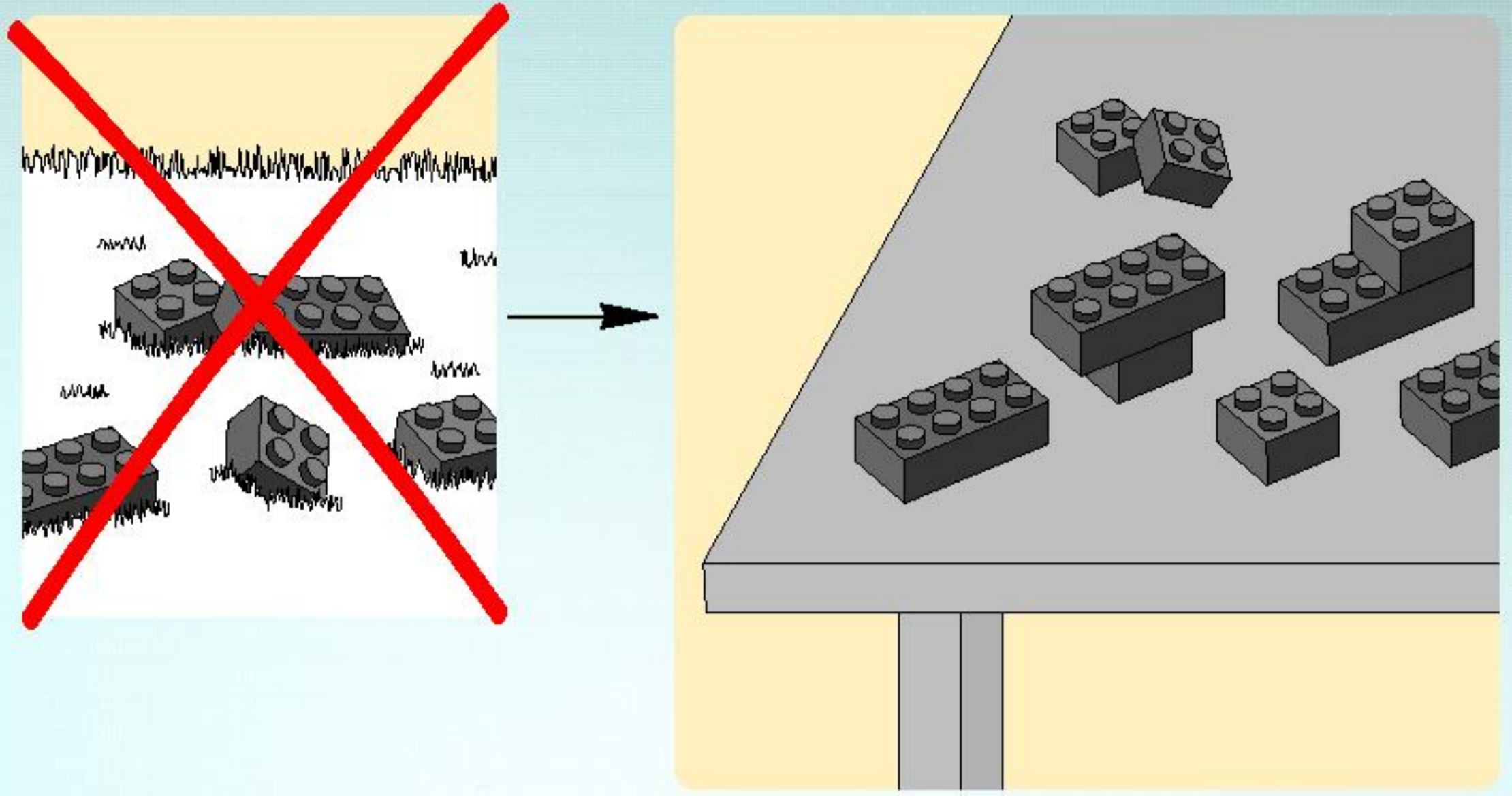

2

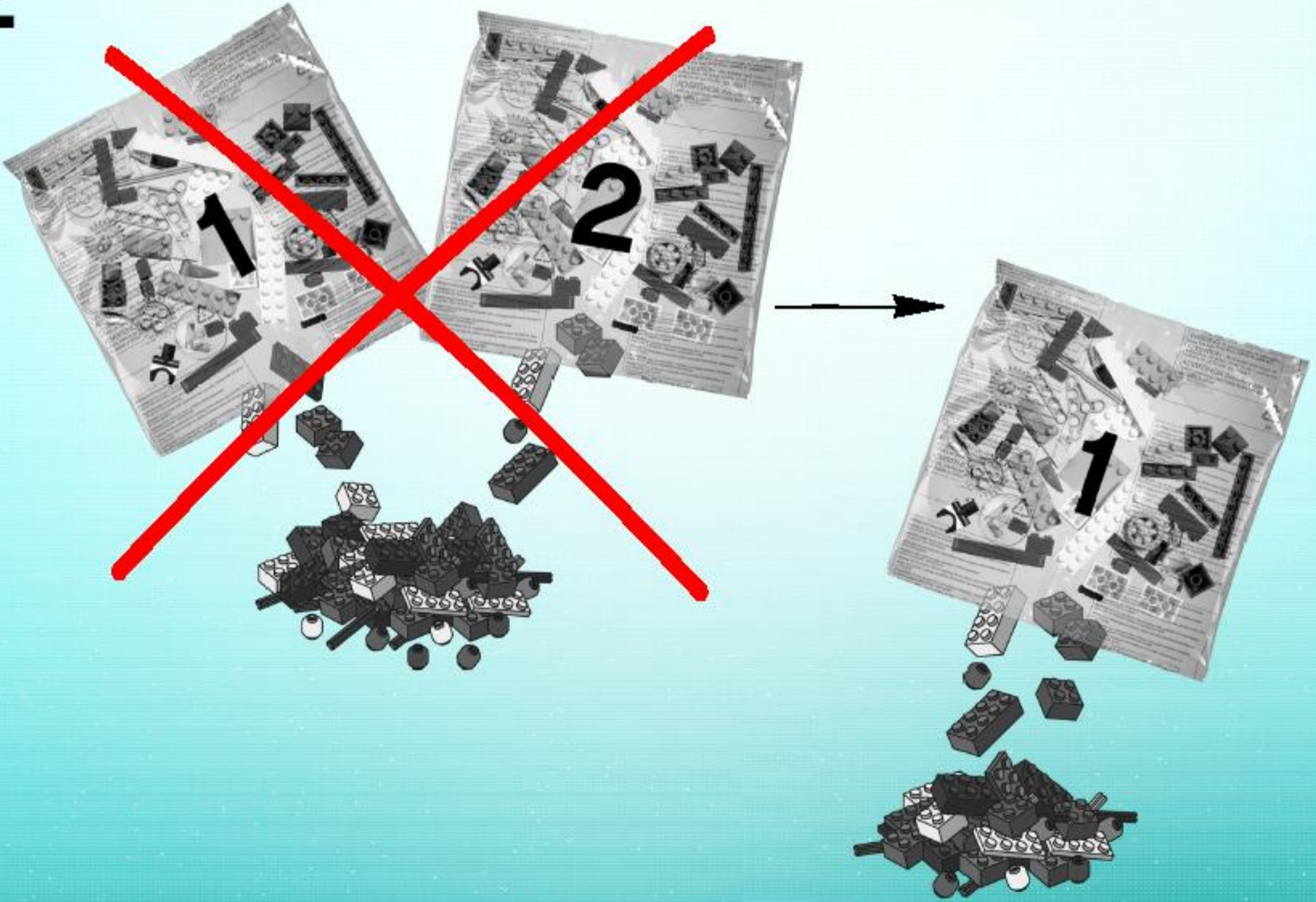

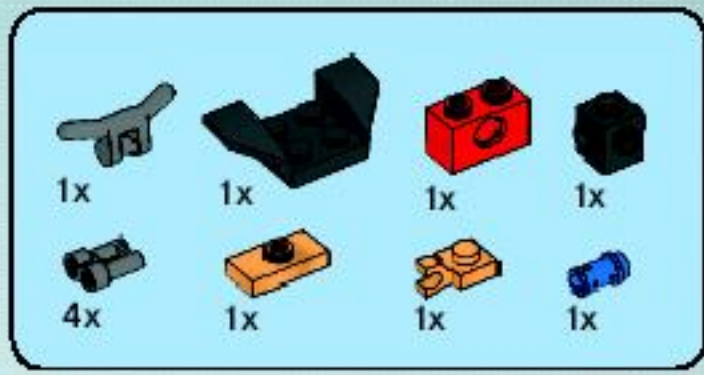
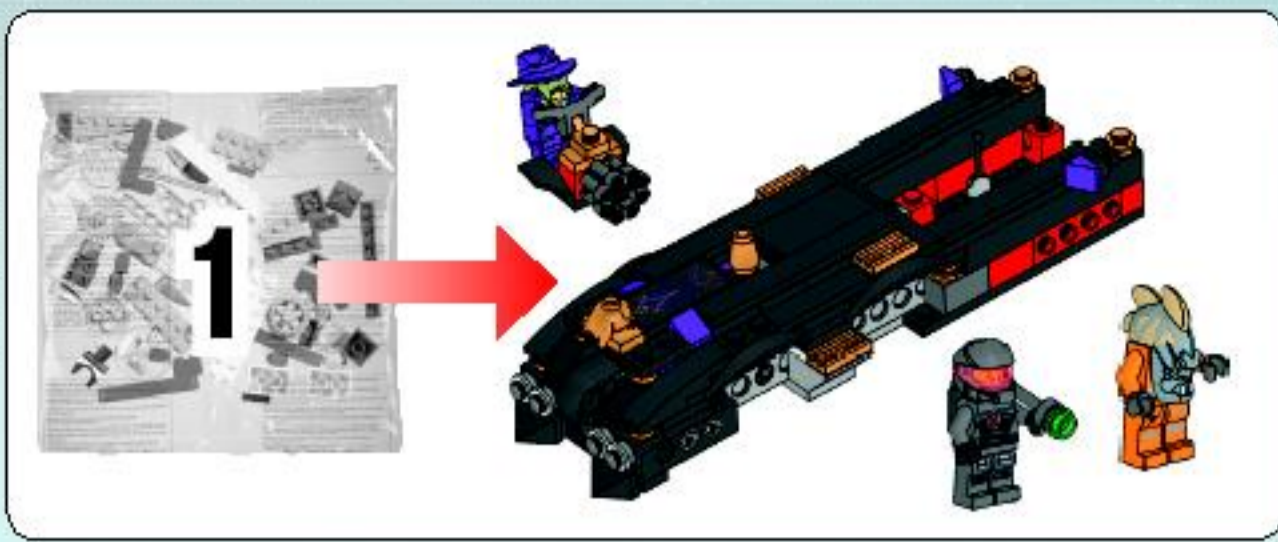

3

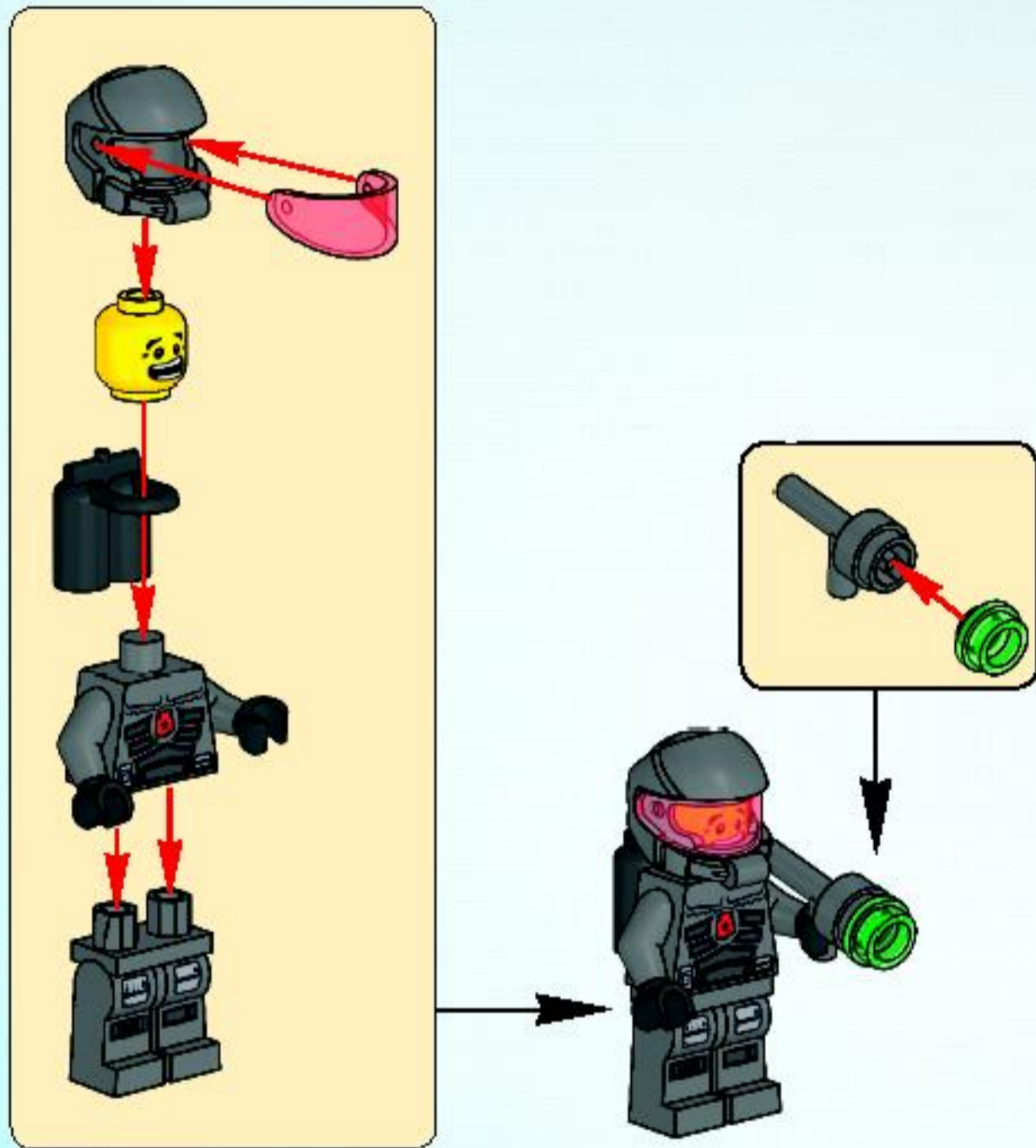

4

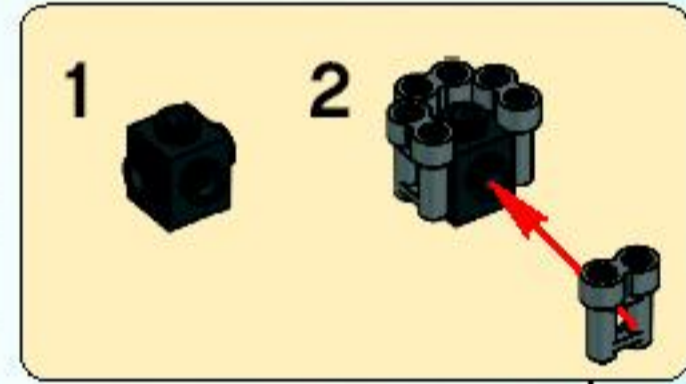
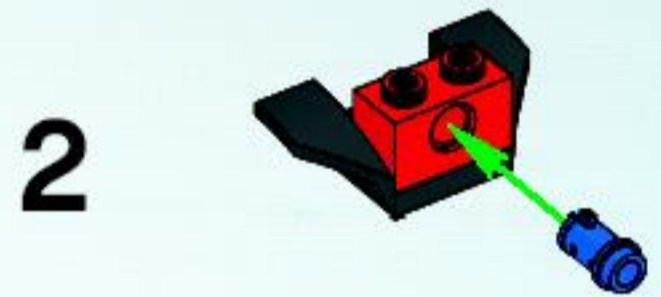
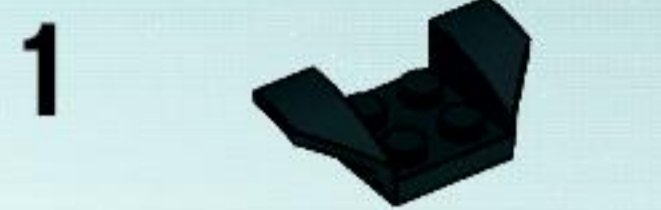

4

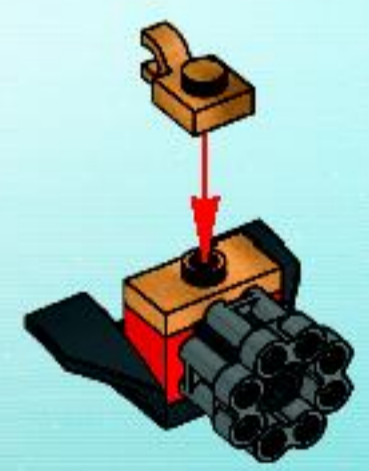

5



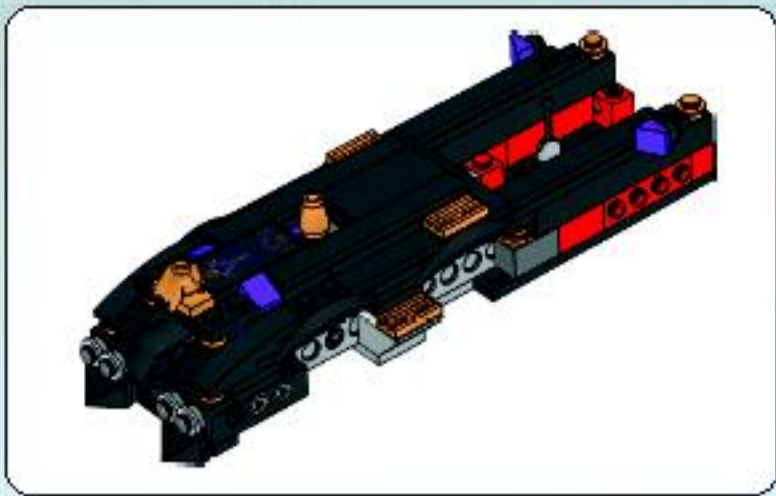

1

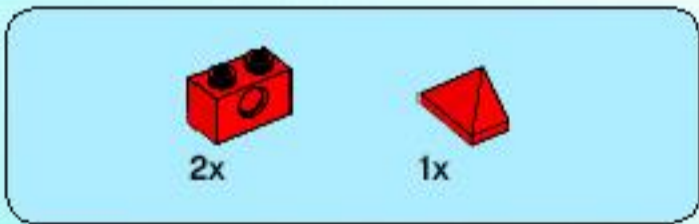

2

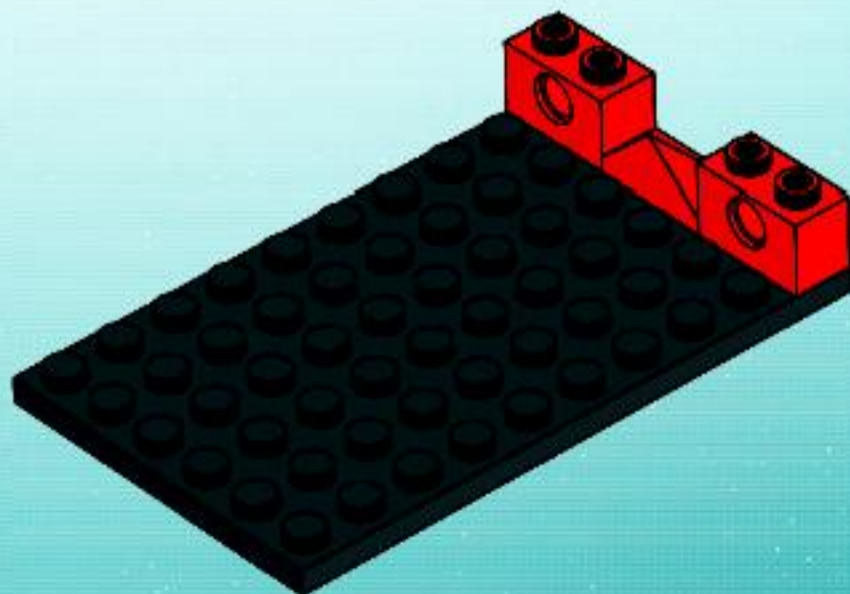

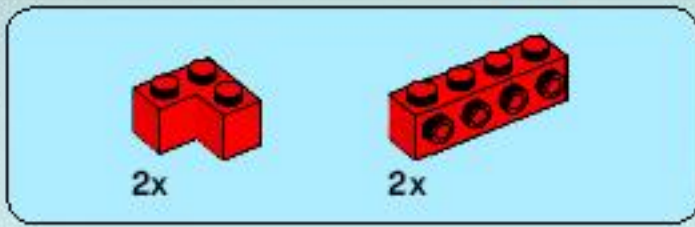

3

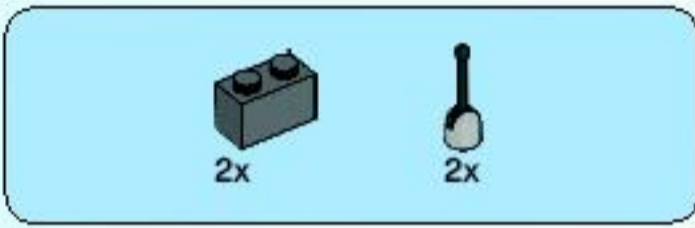
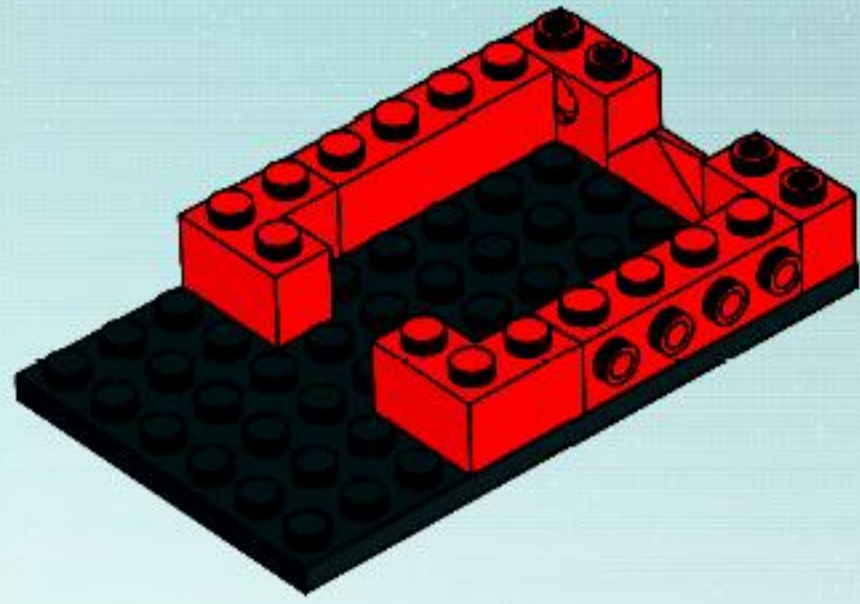

4

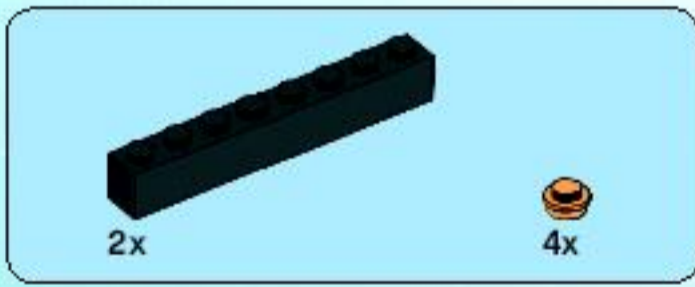
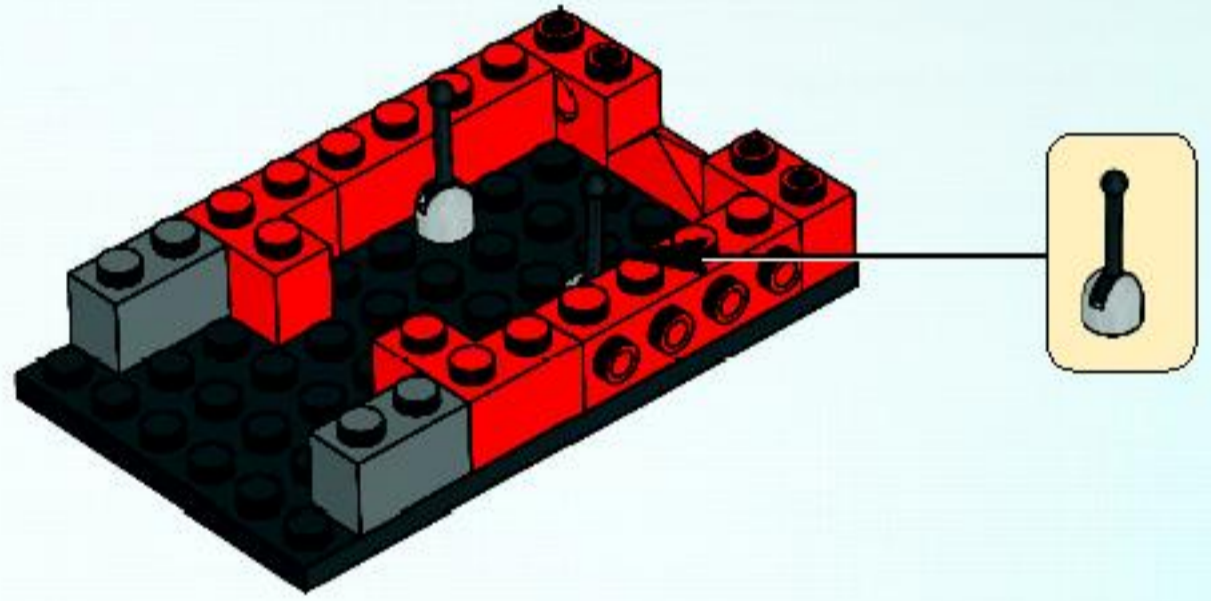

5

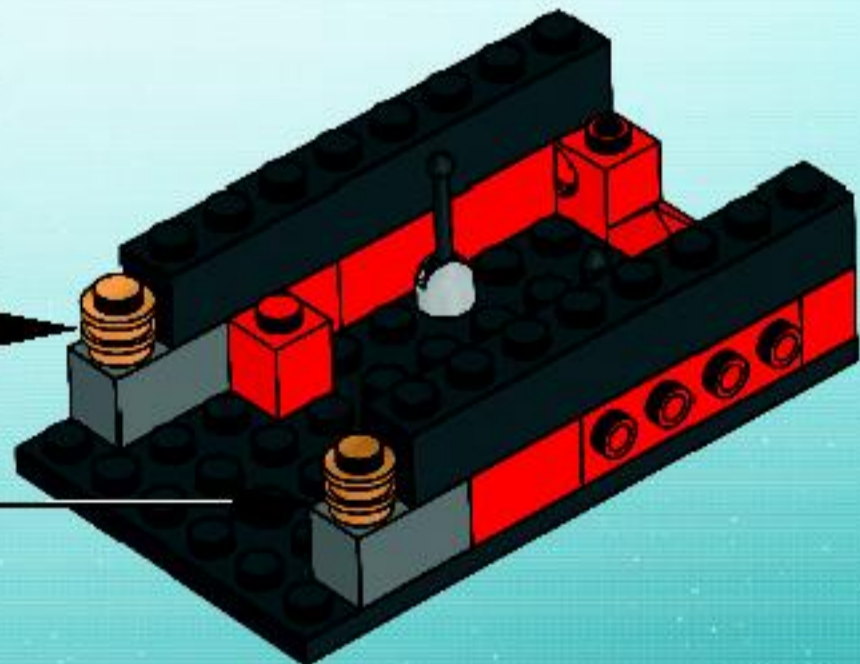
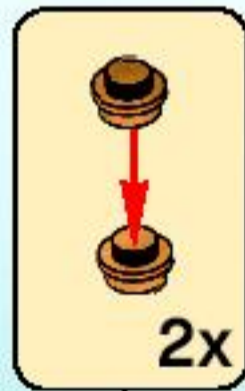

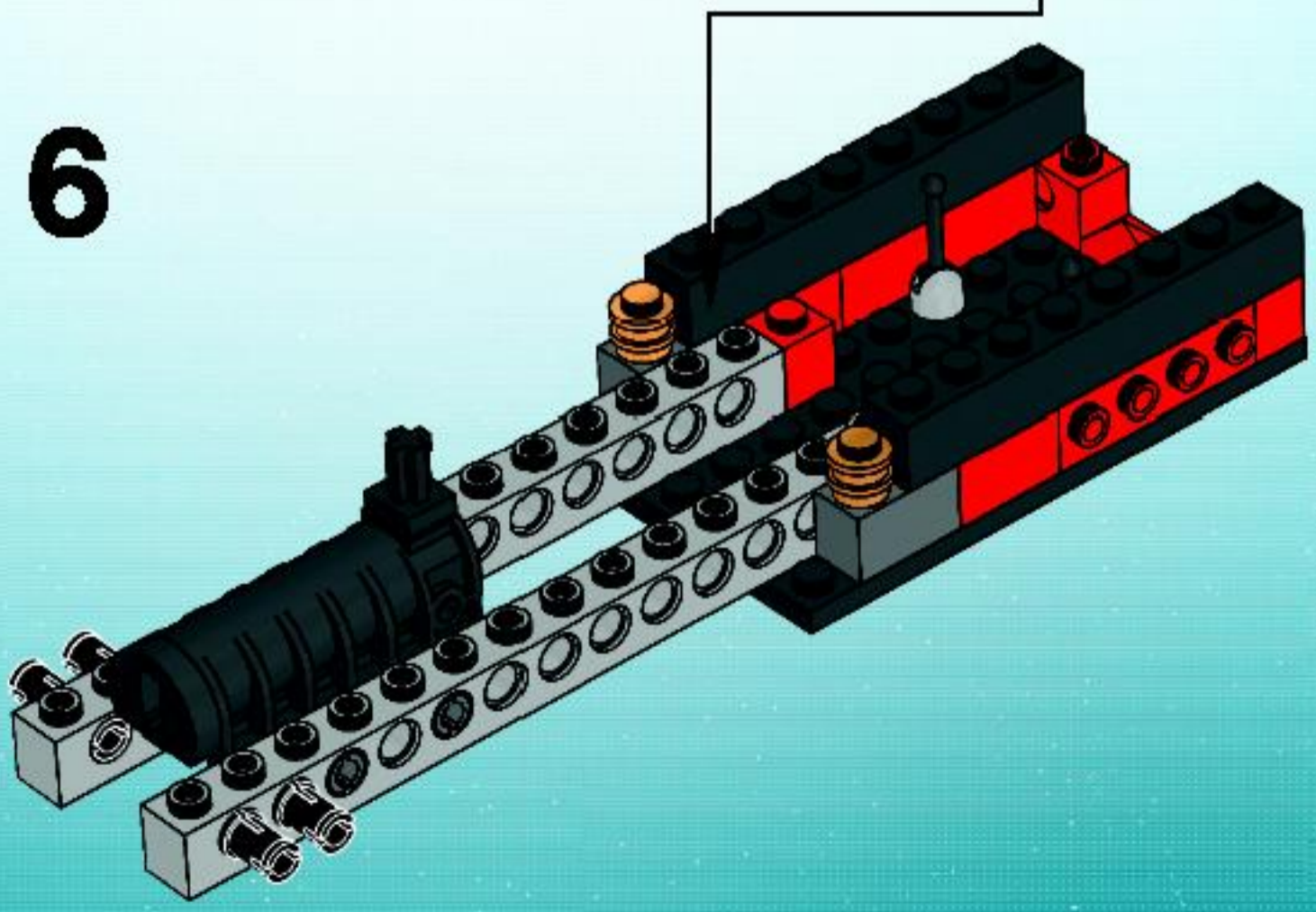
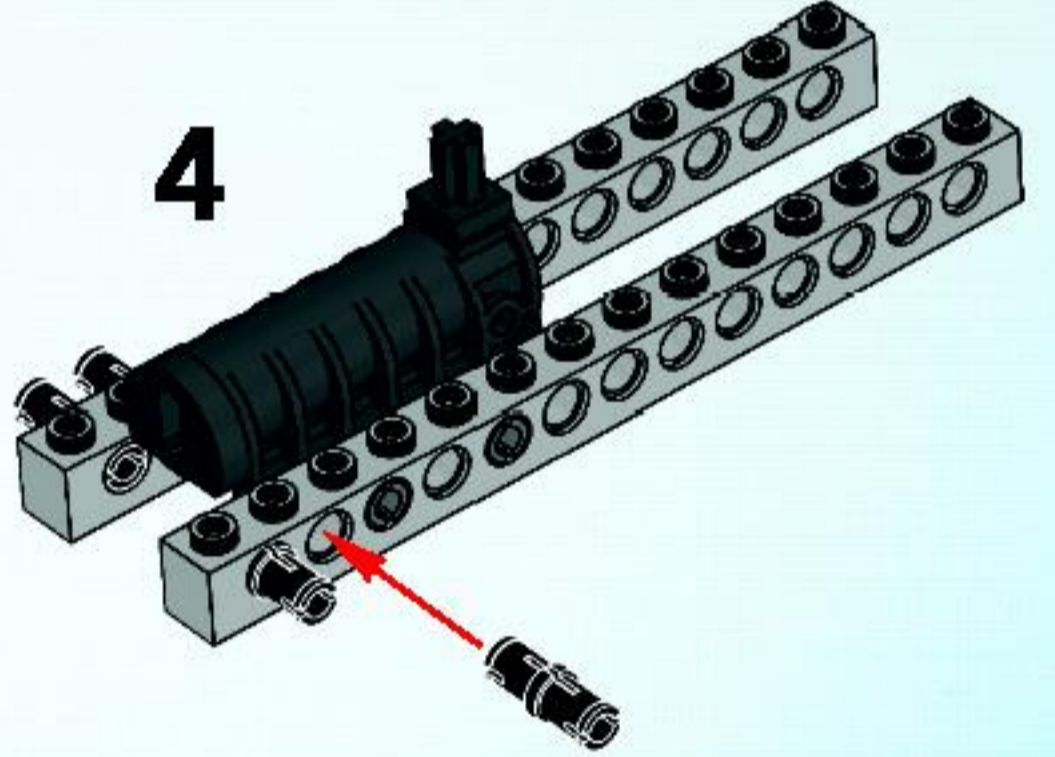
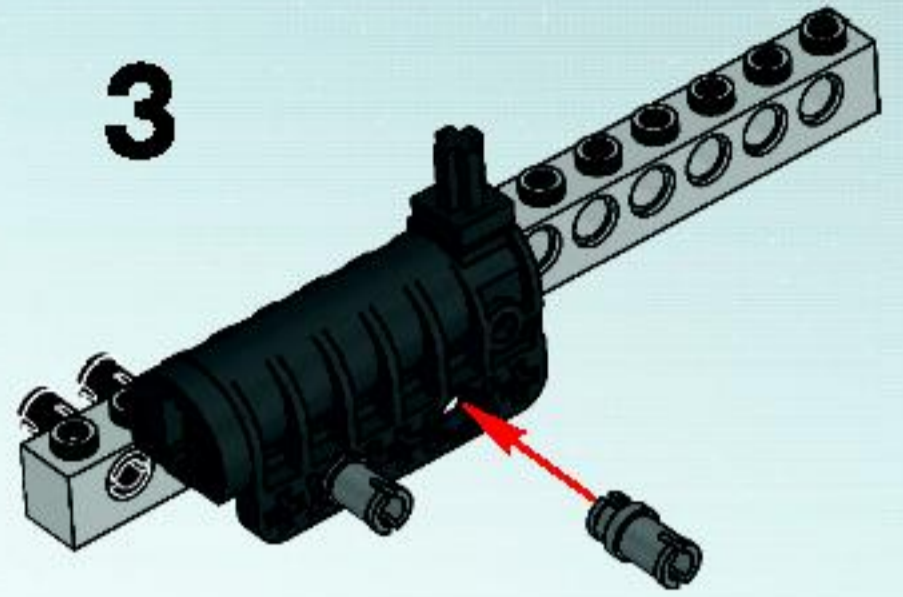
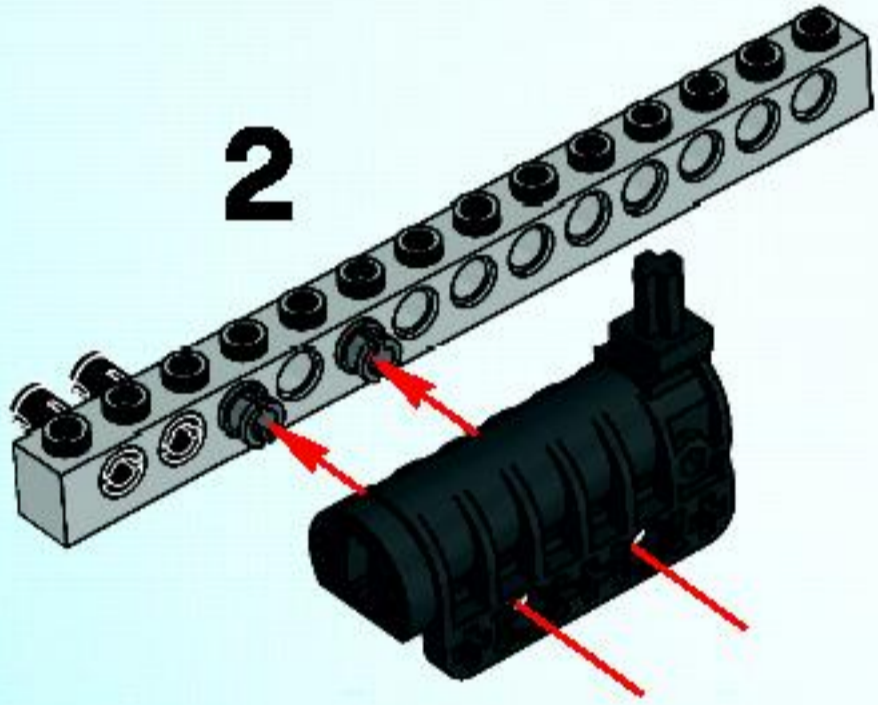
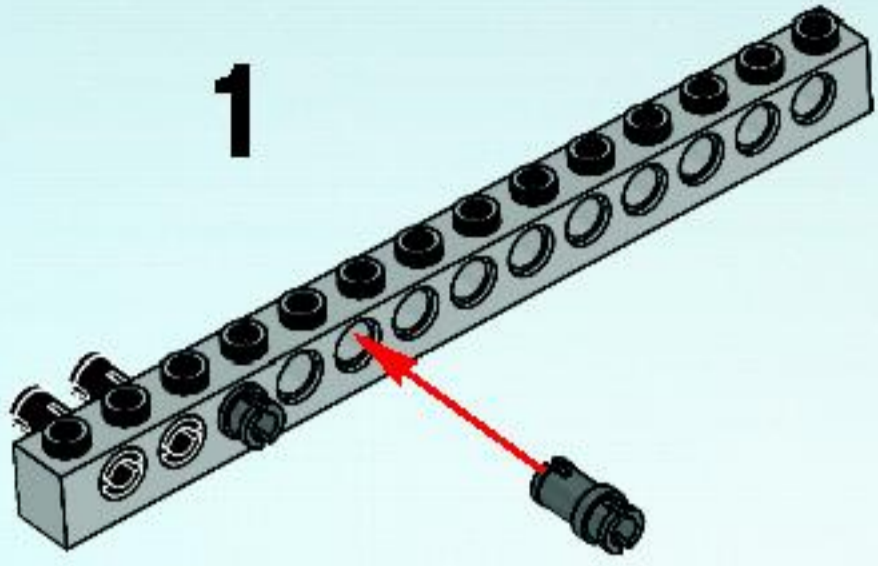
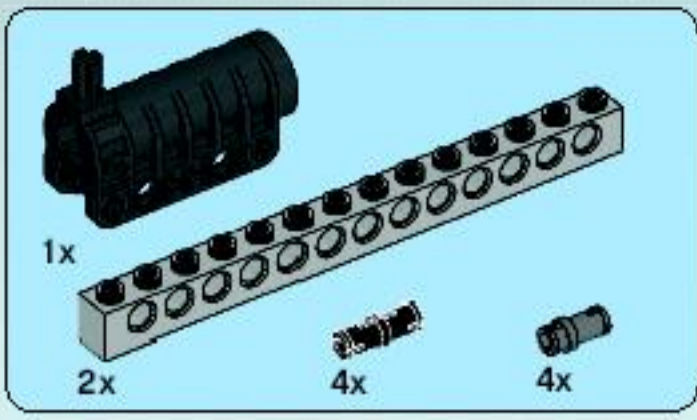



7

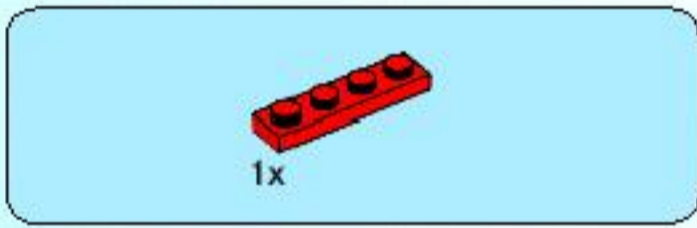
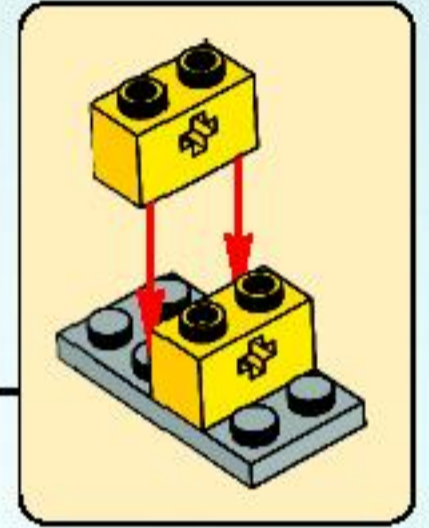
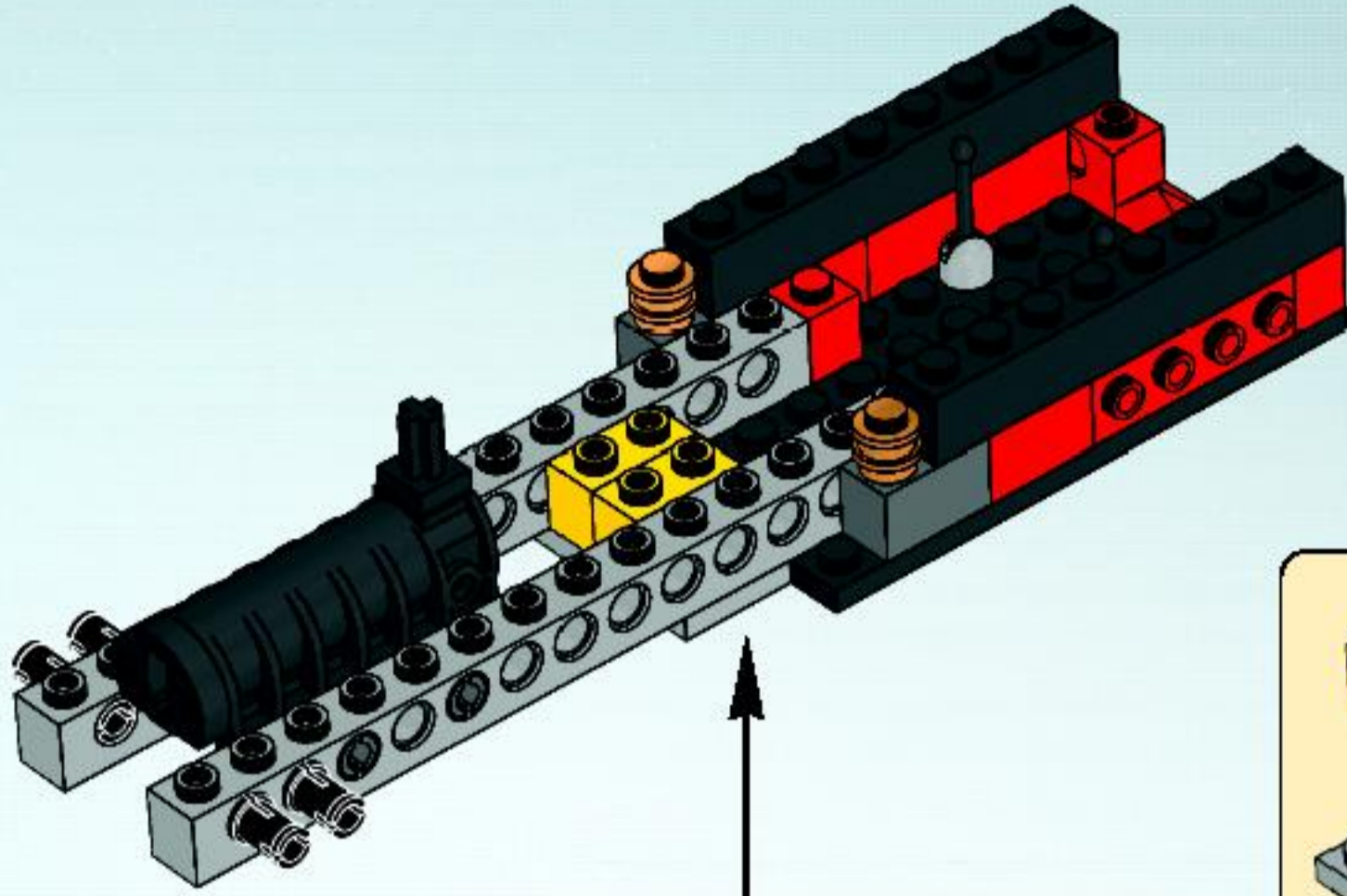

8

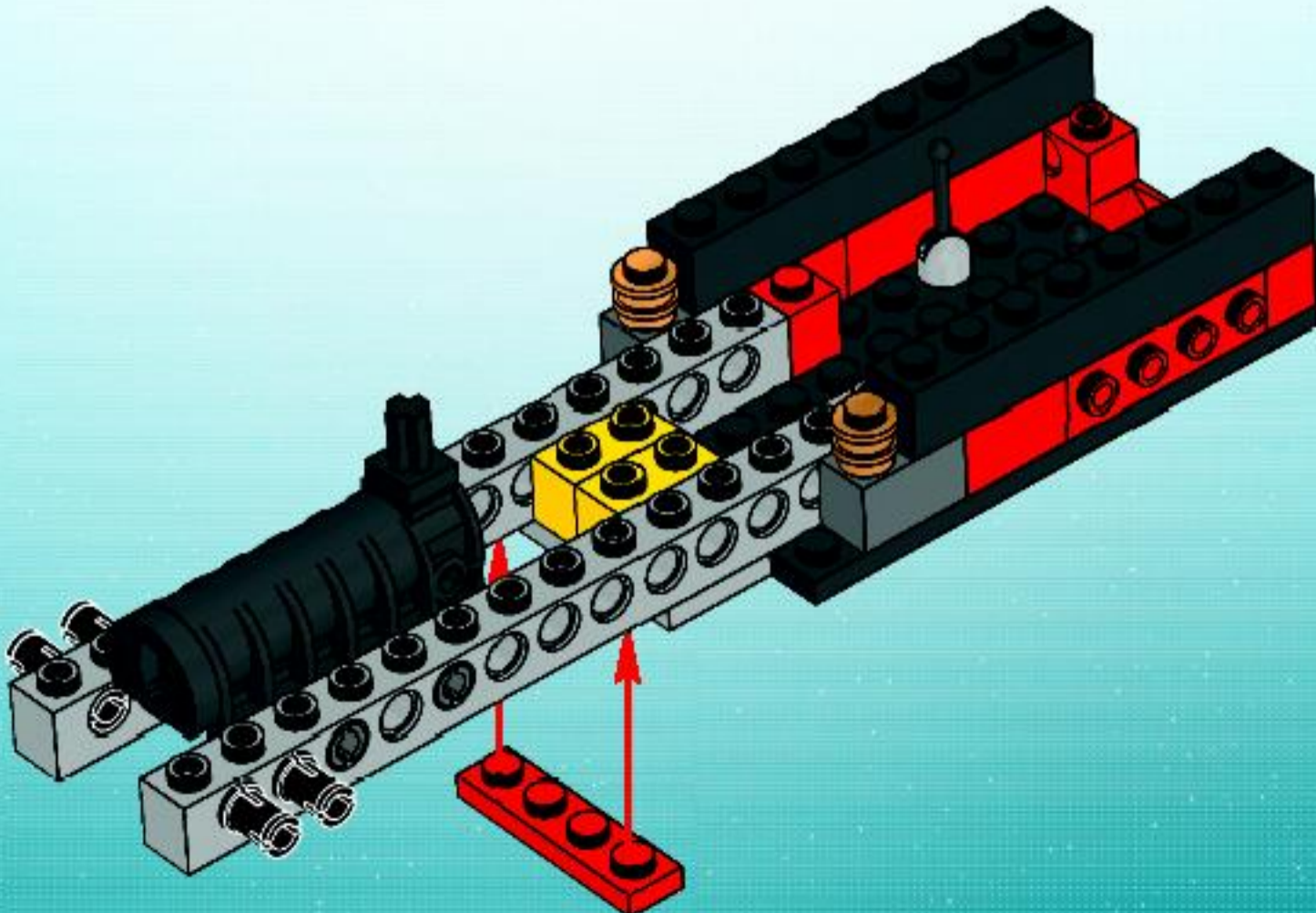



2x

9

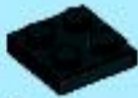
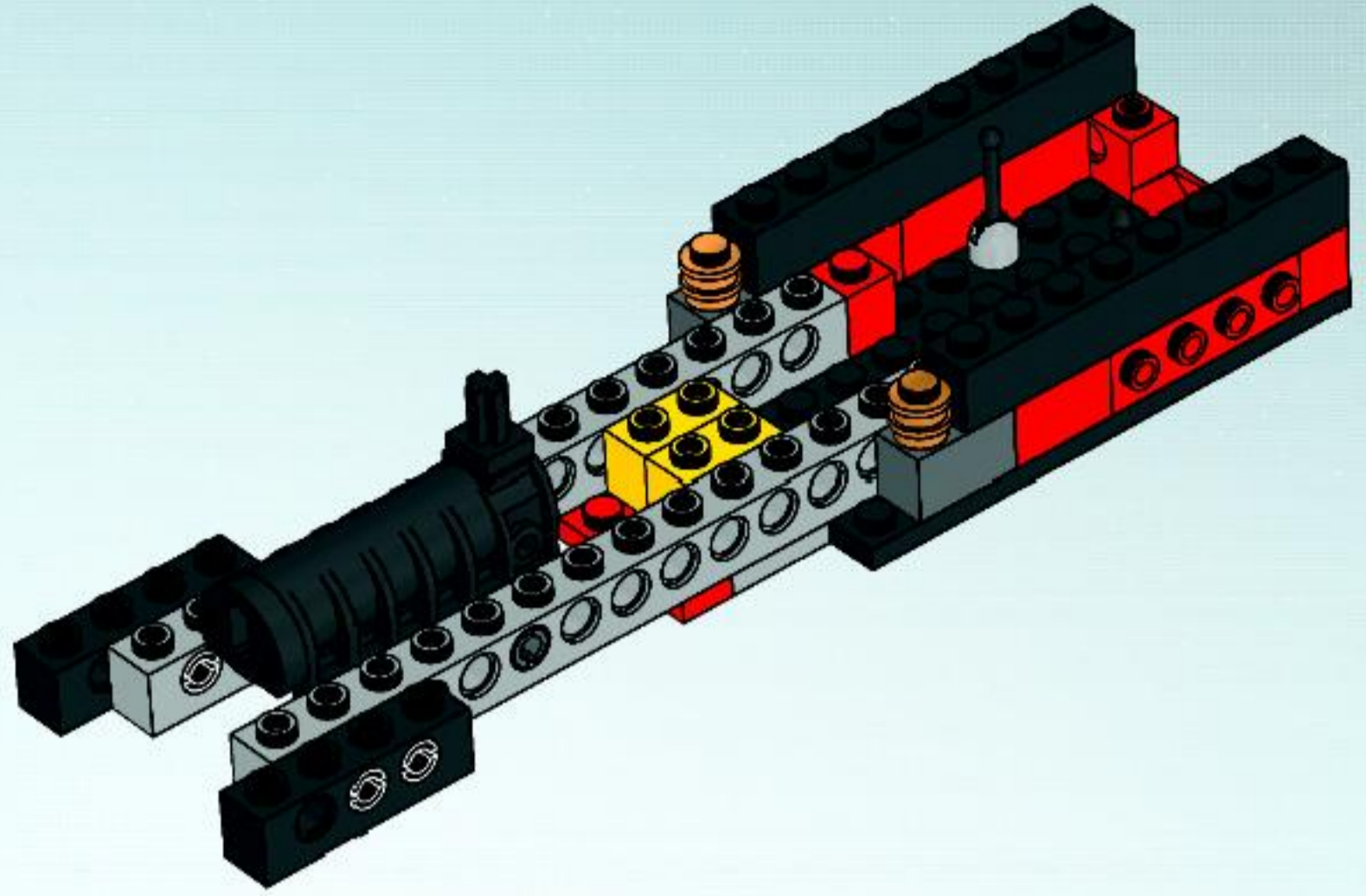

2x



1x

10

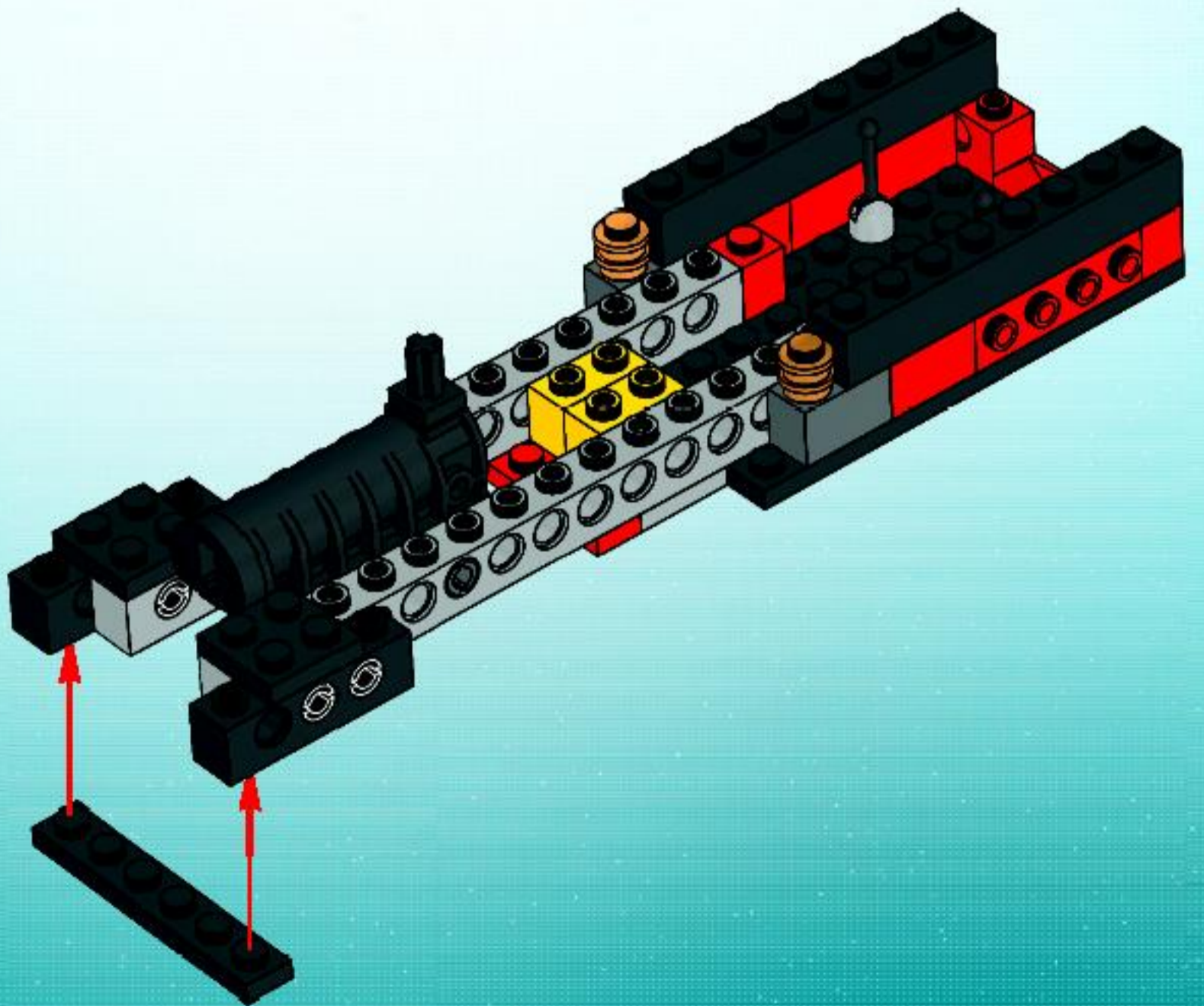

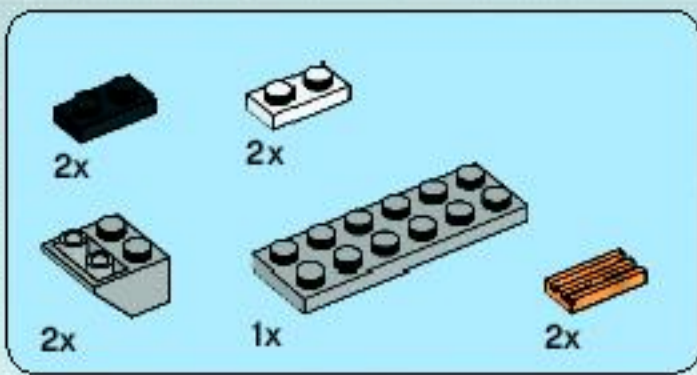

11

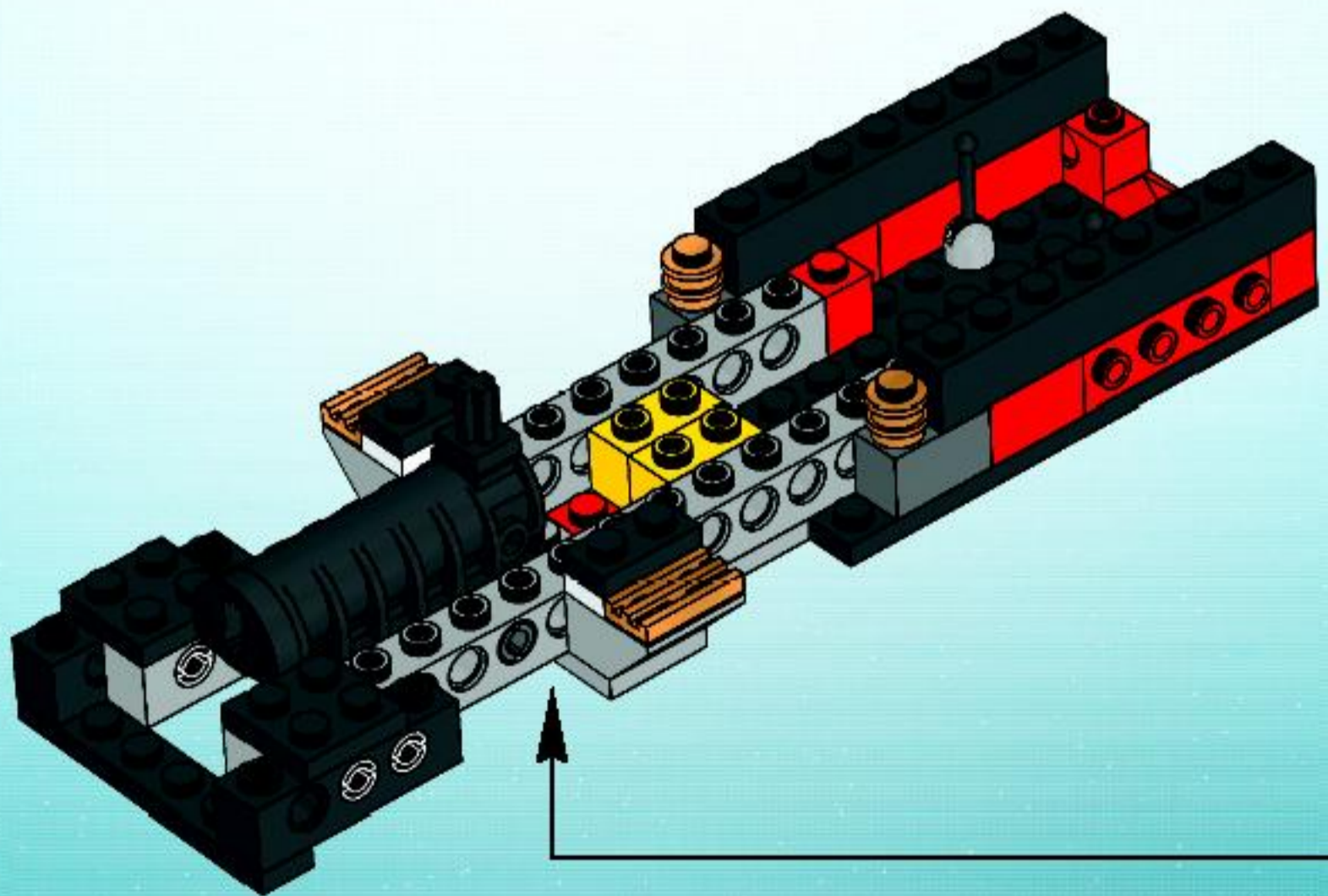
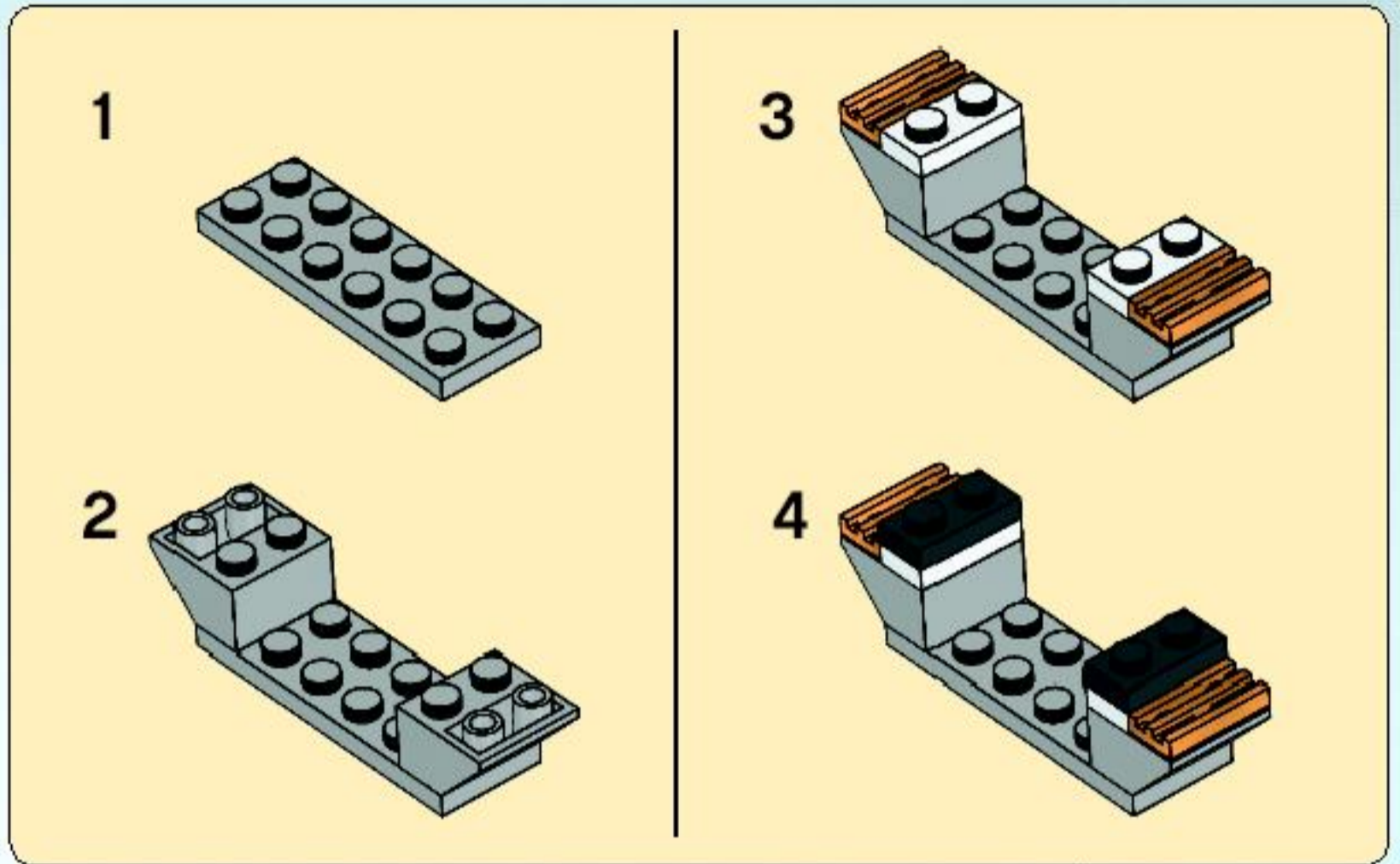



2x

12

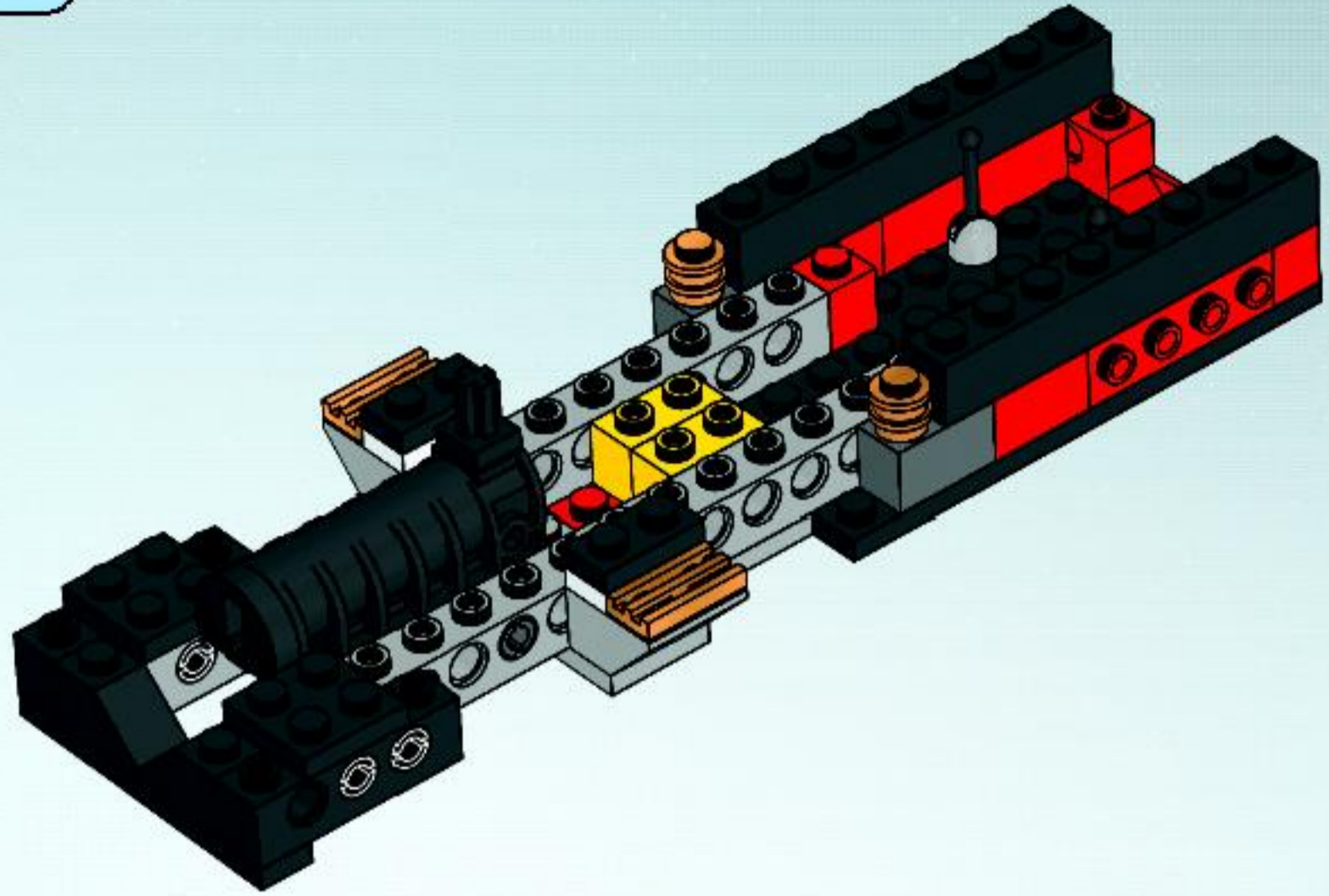

2x

13

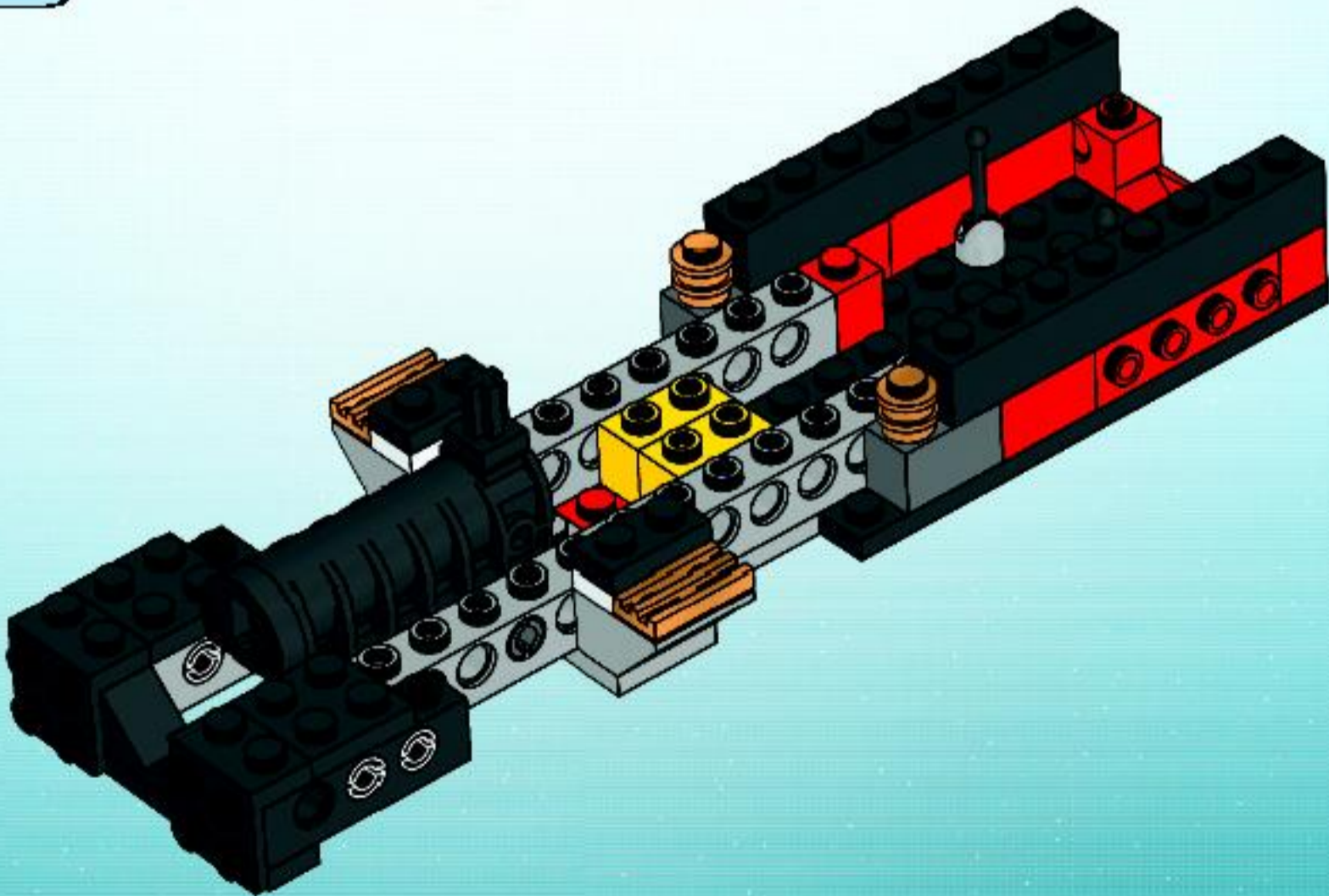



14

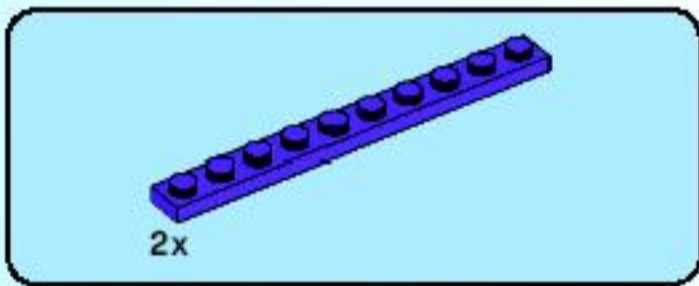
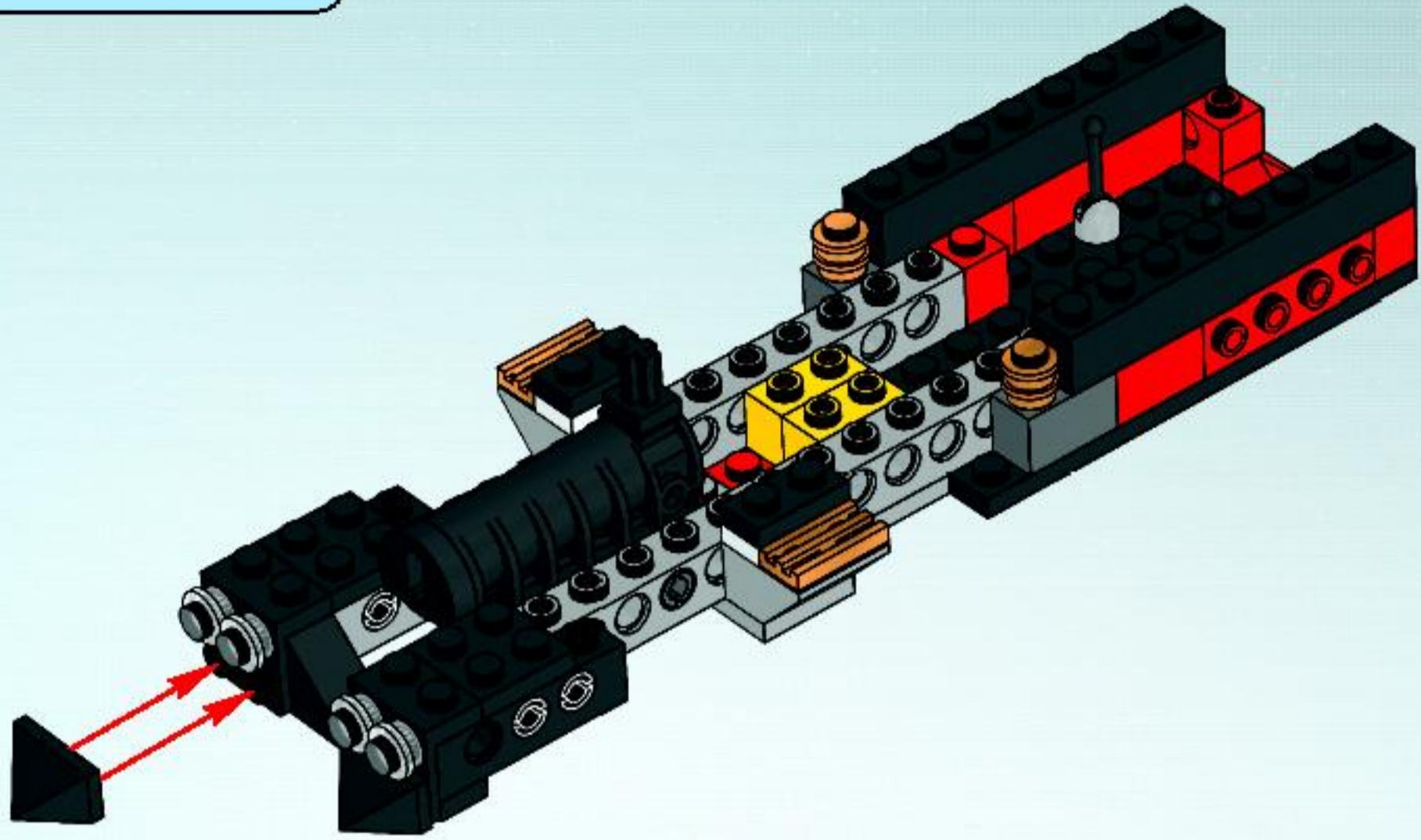

15

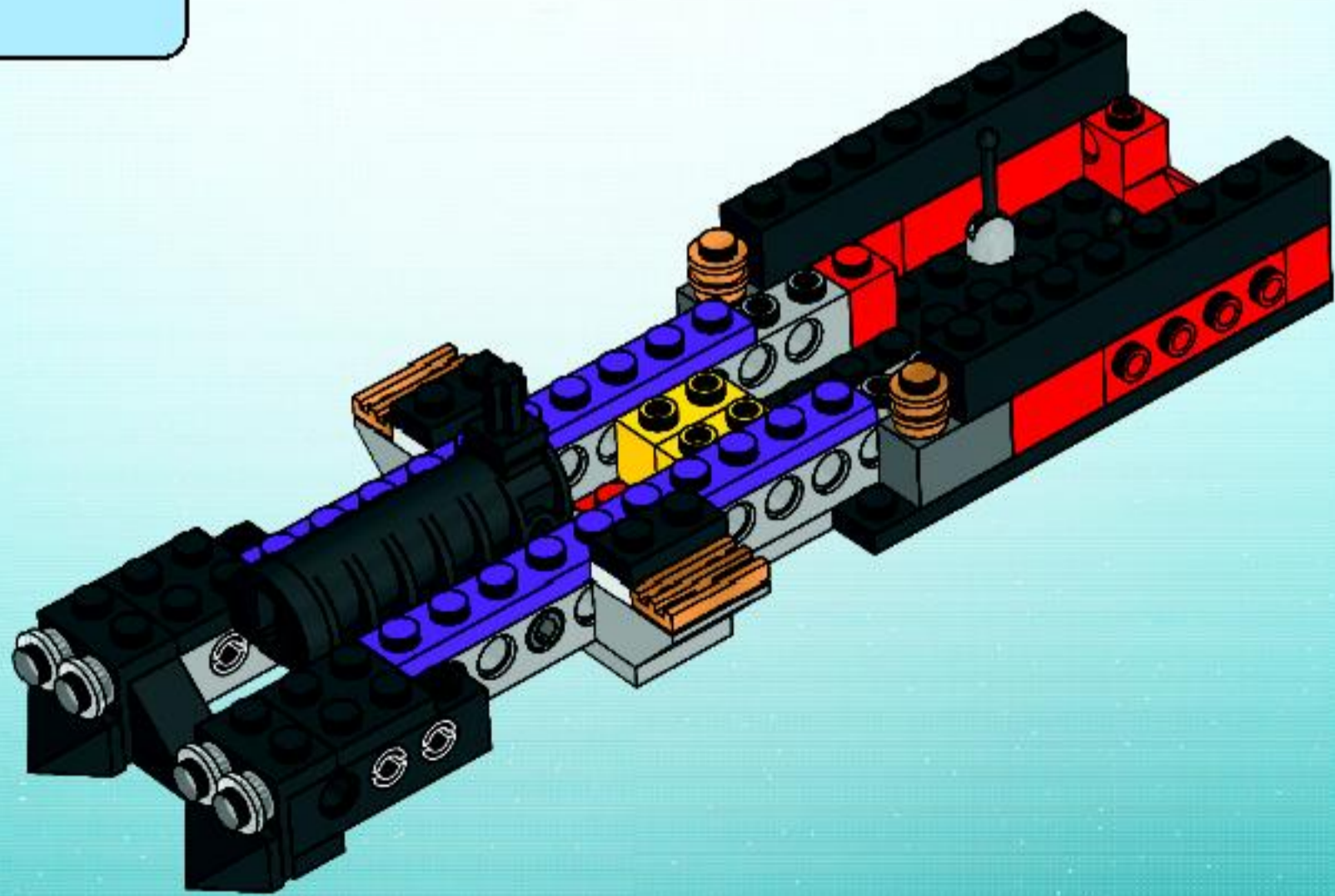



2x



2x

16

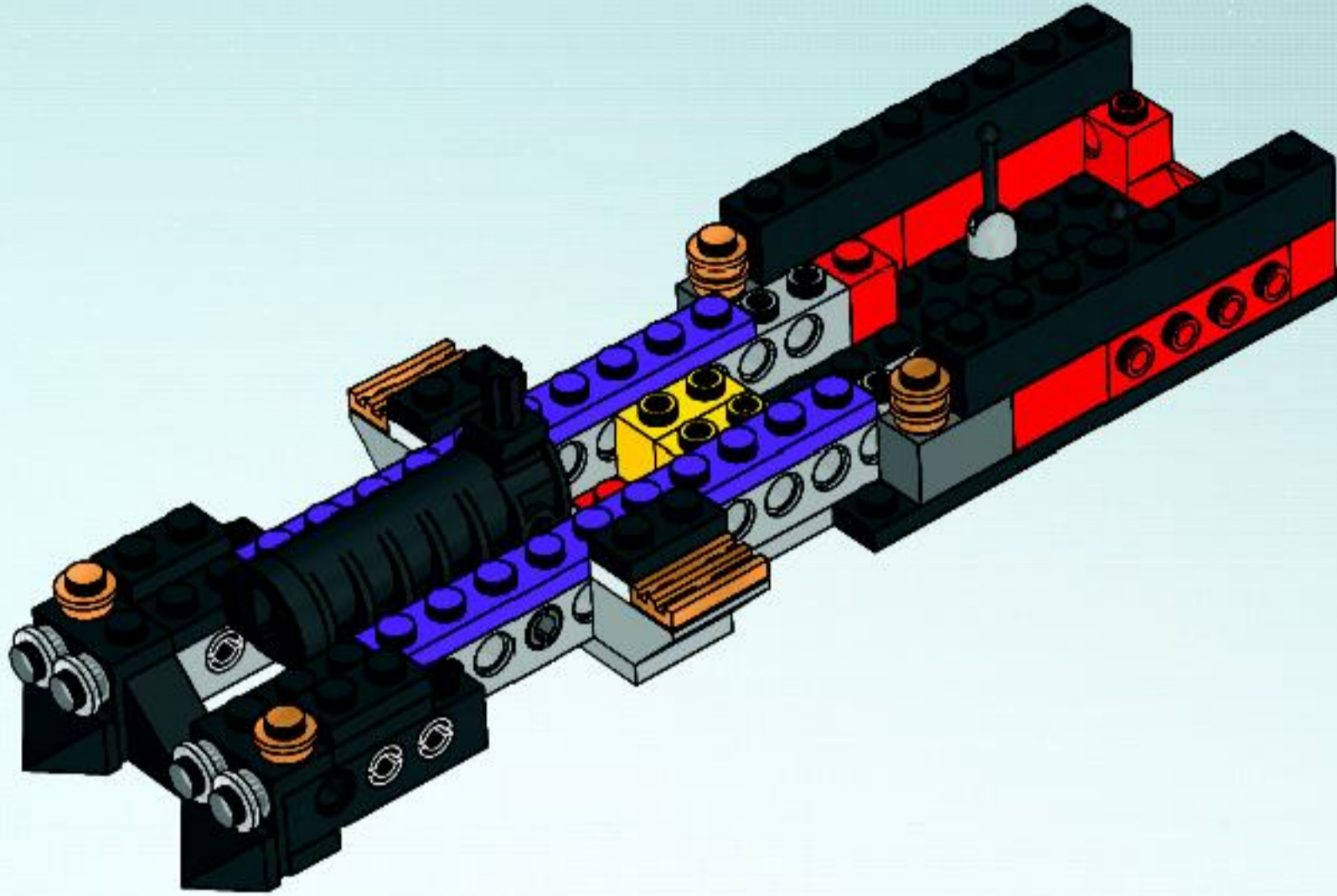

2x

17

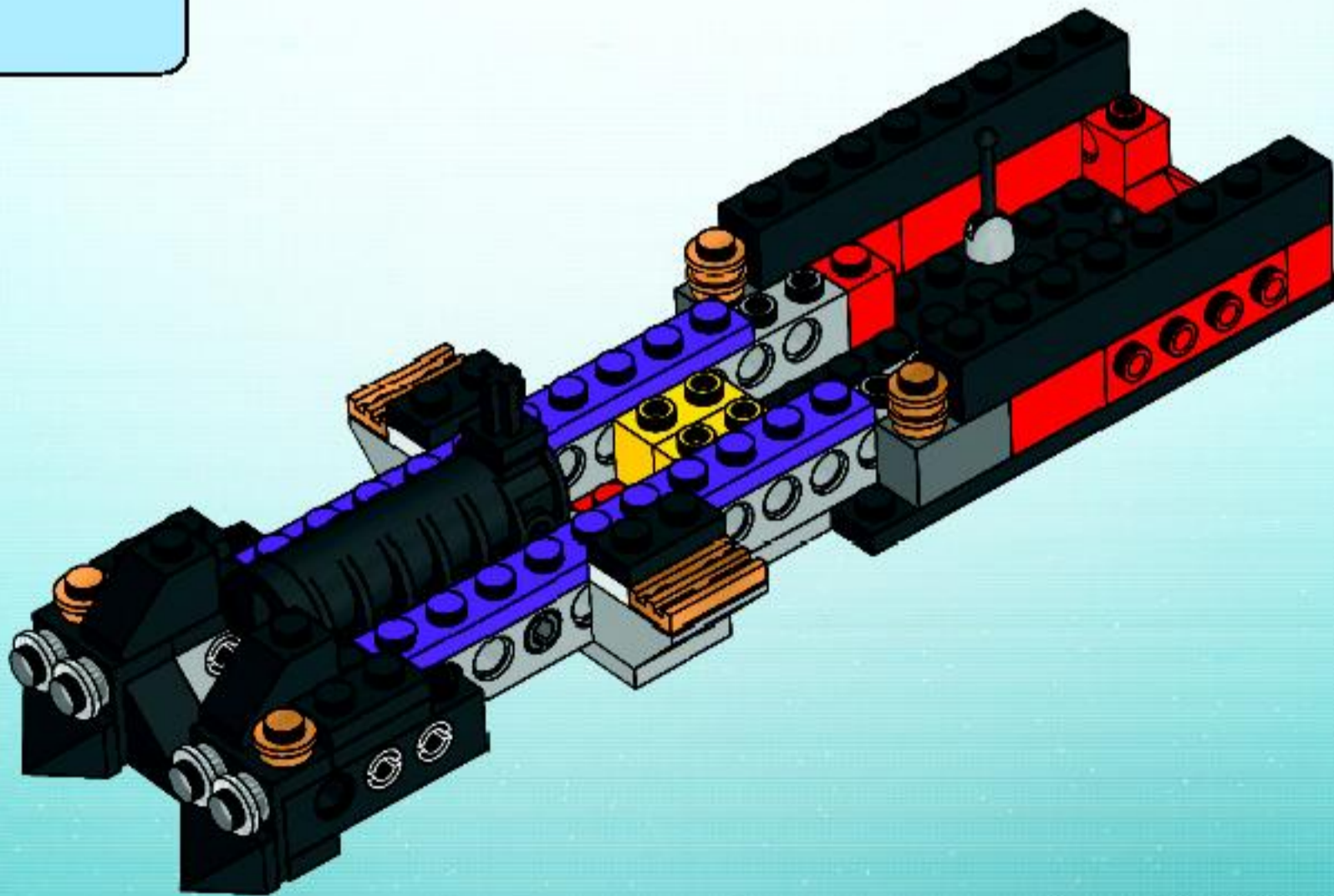

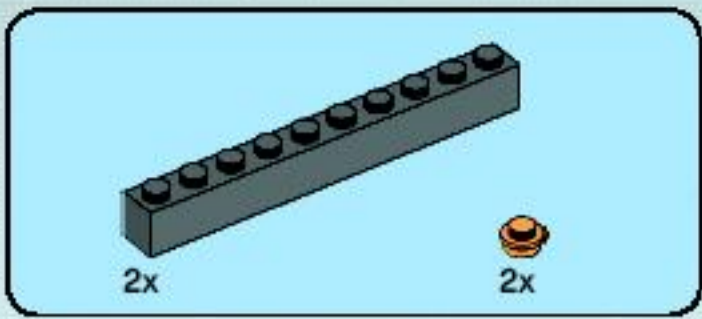

18

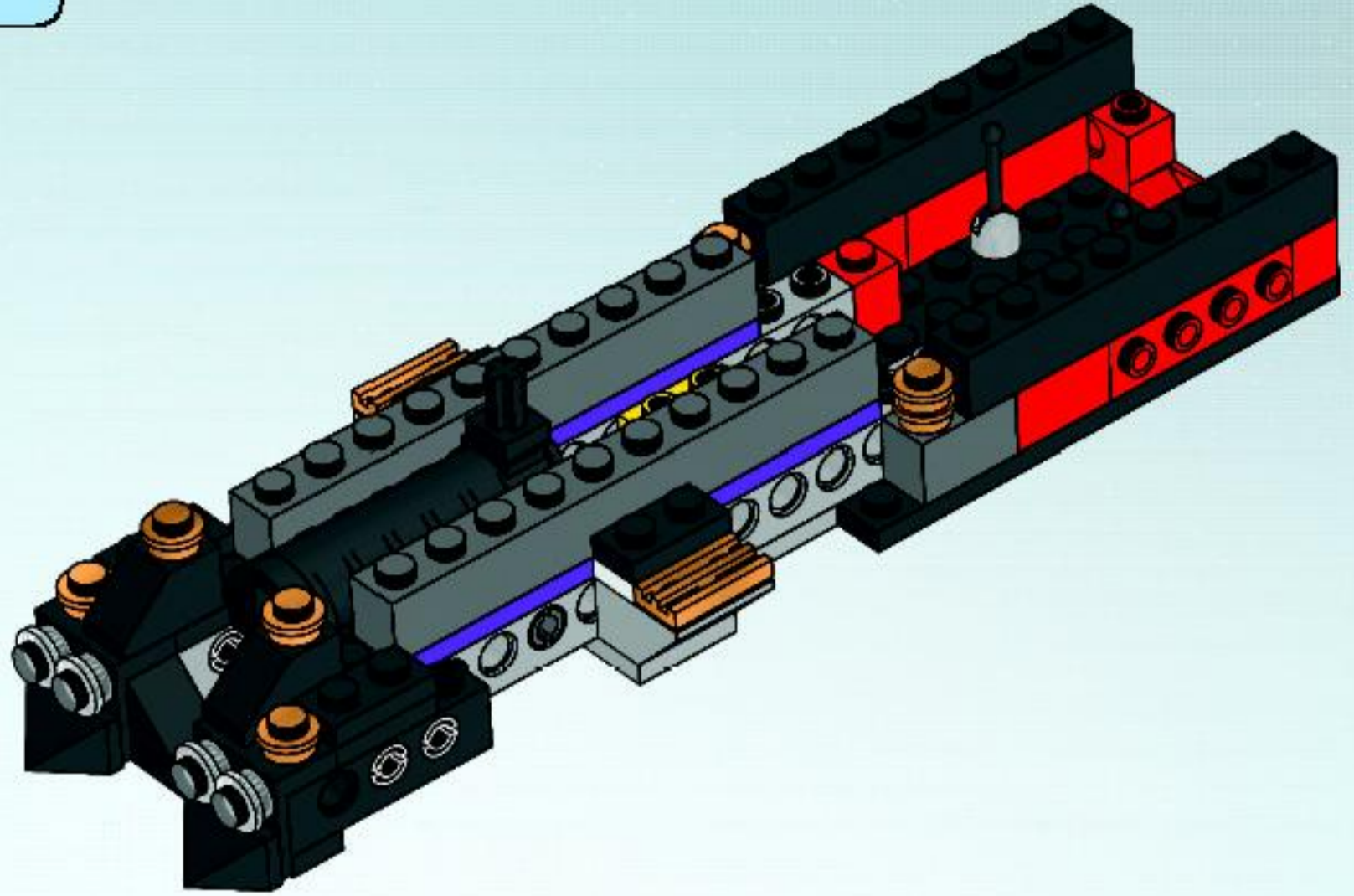

19

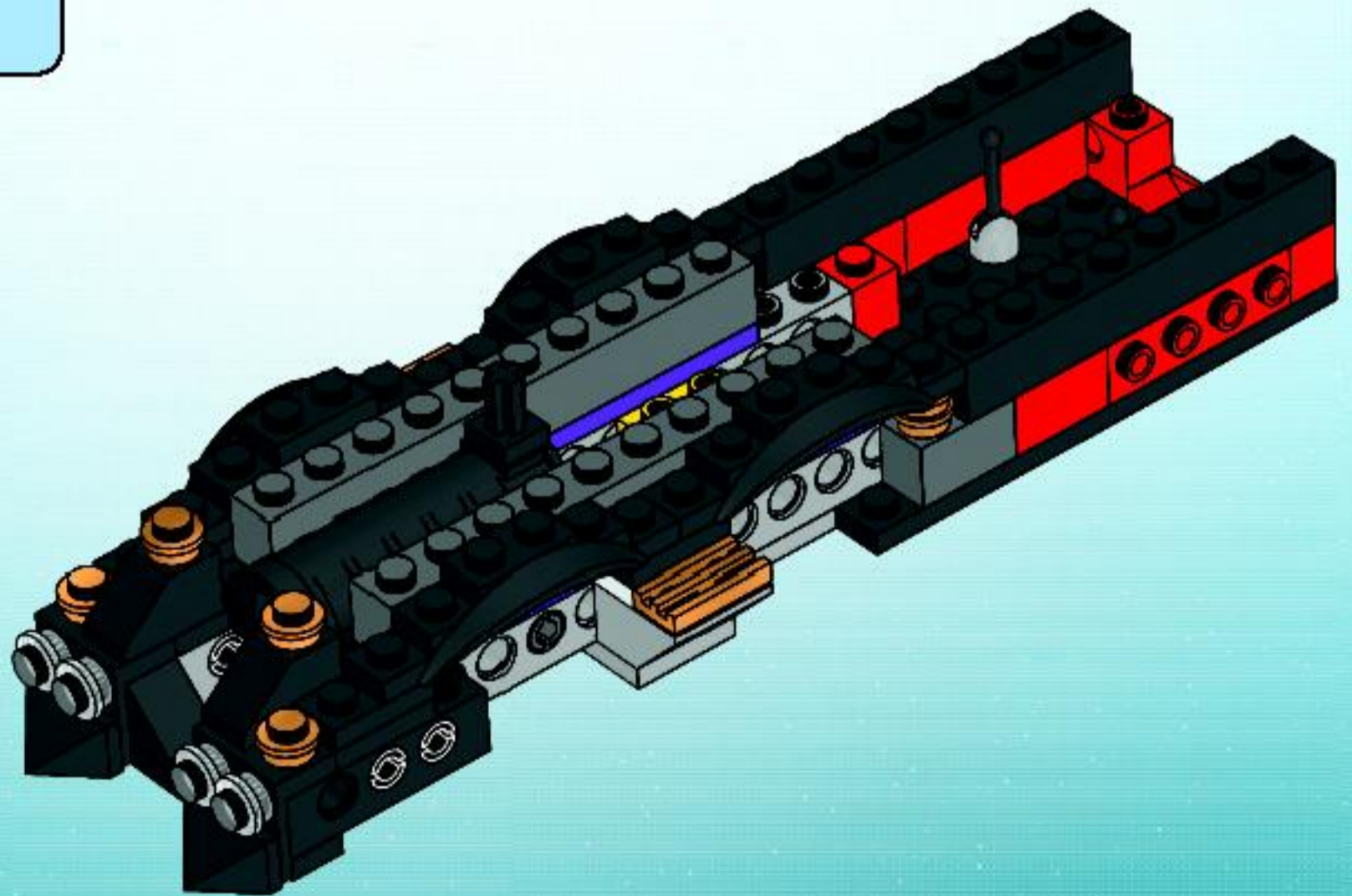

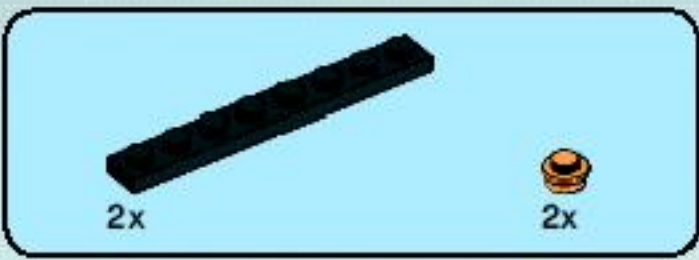

20

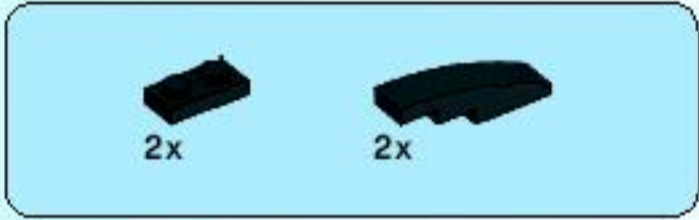
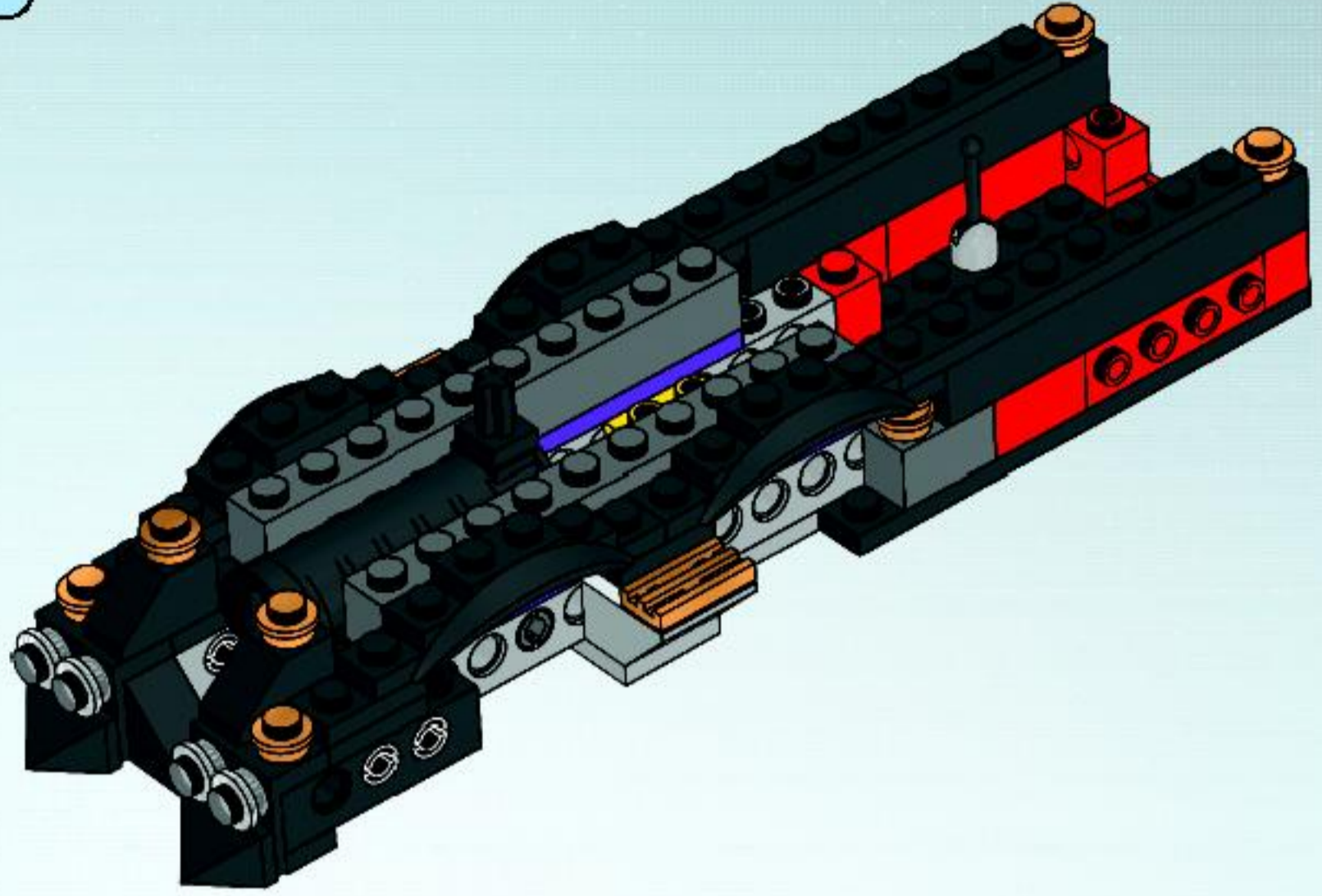

21

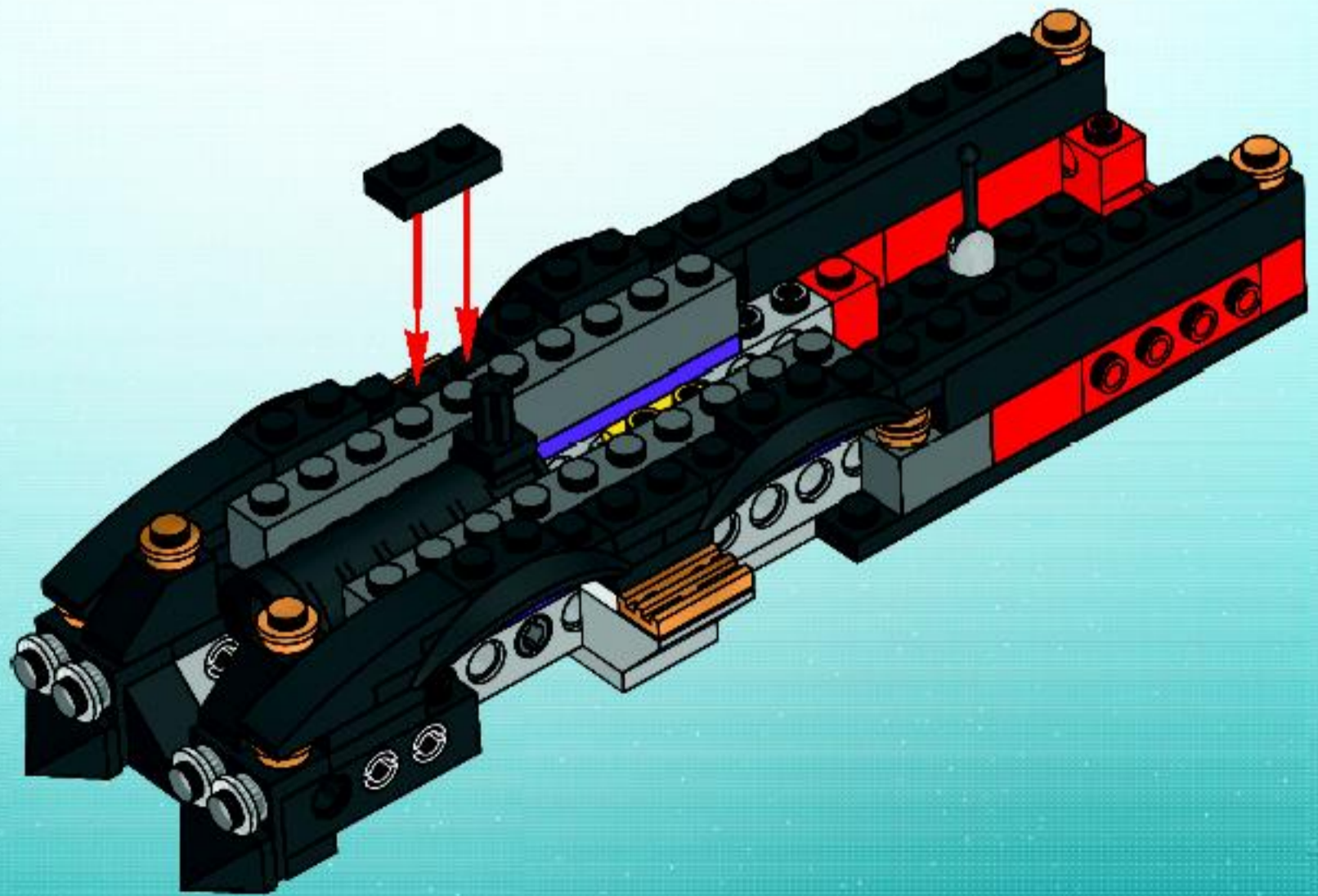

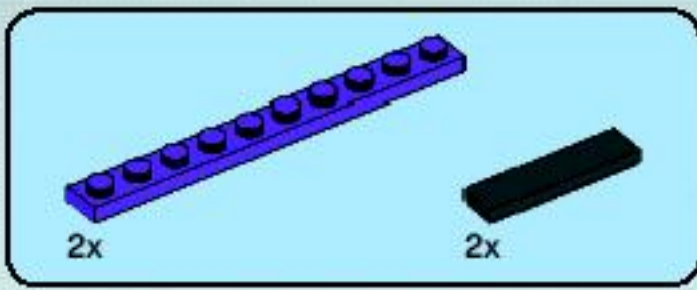

22

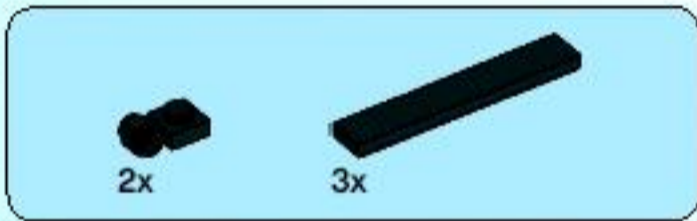
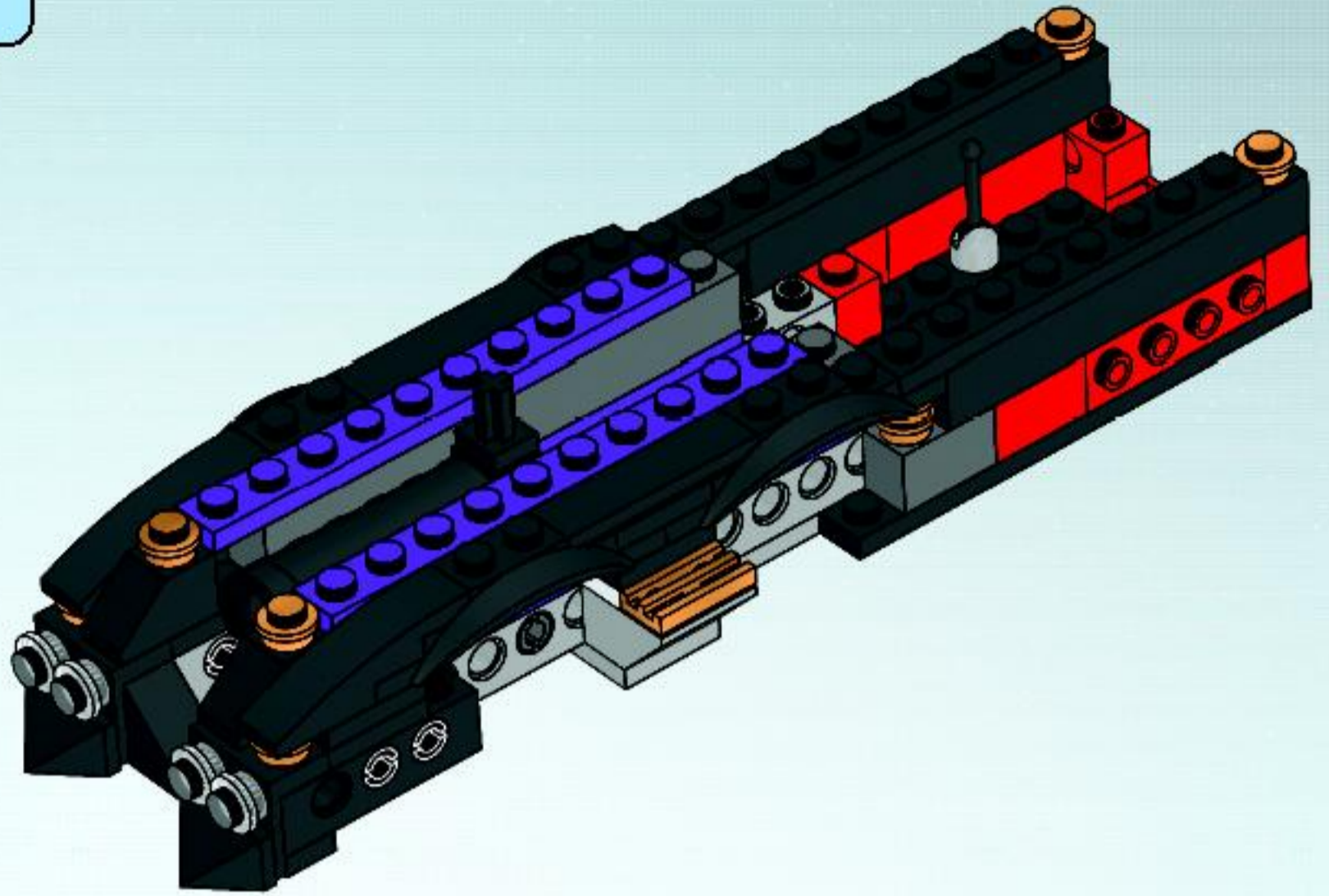

23

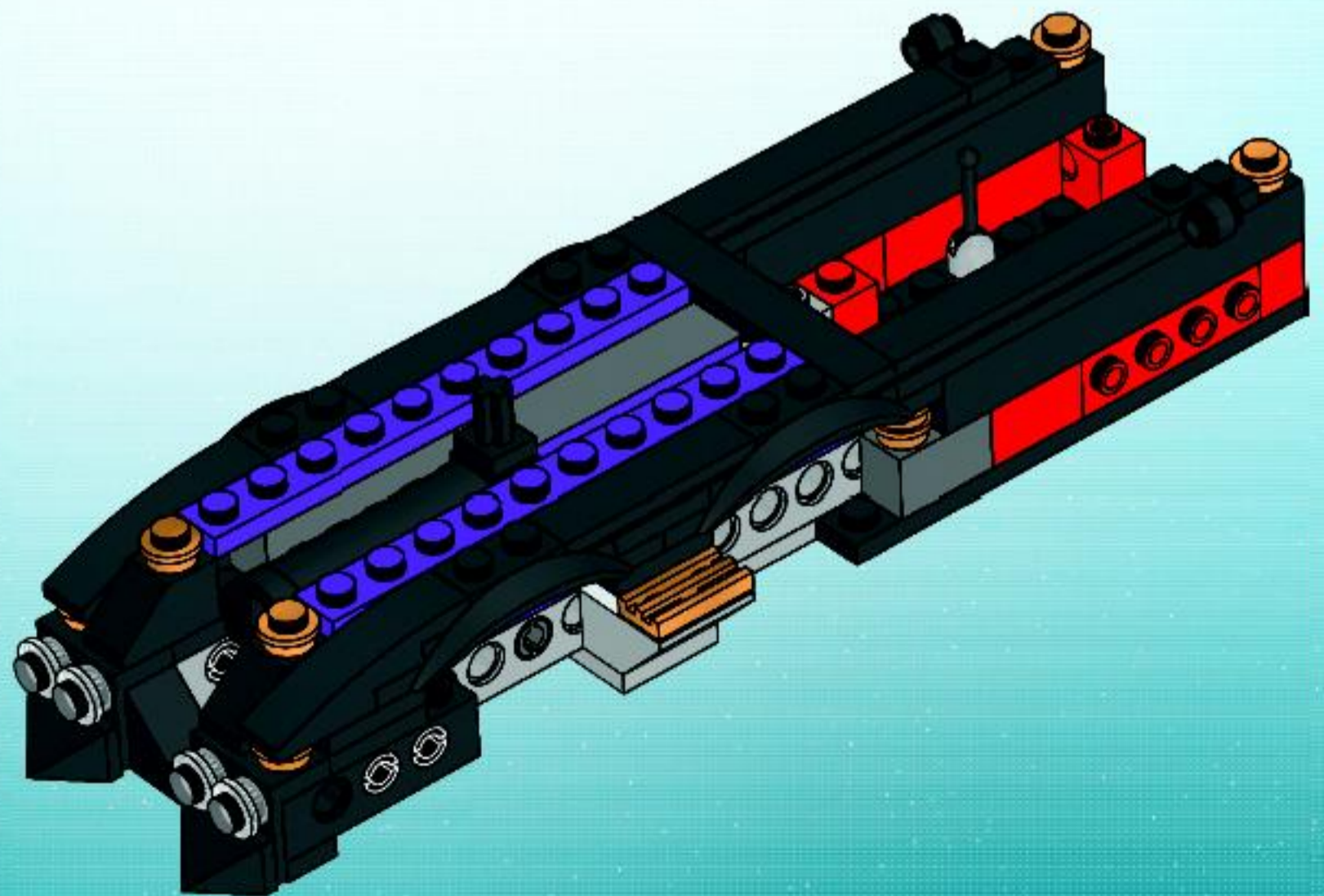

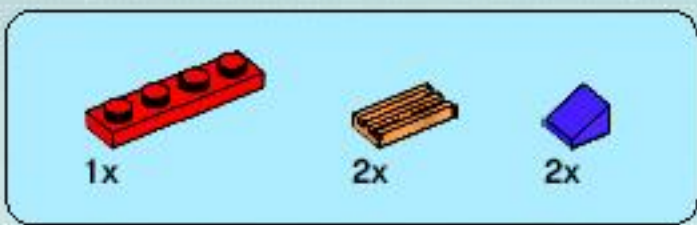

24

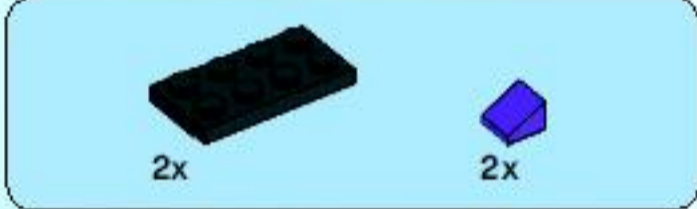
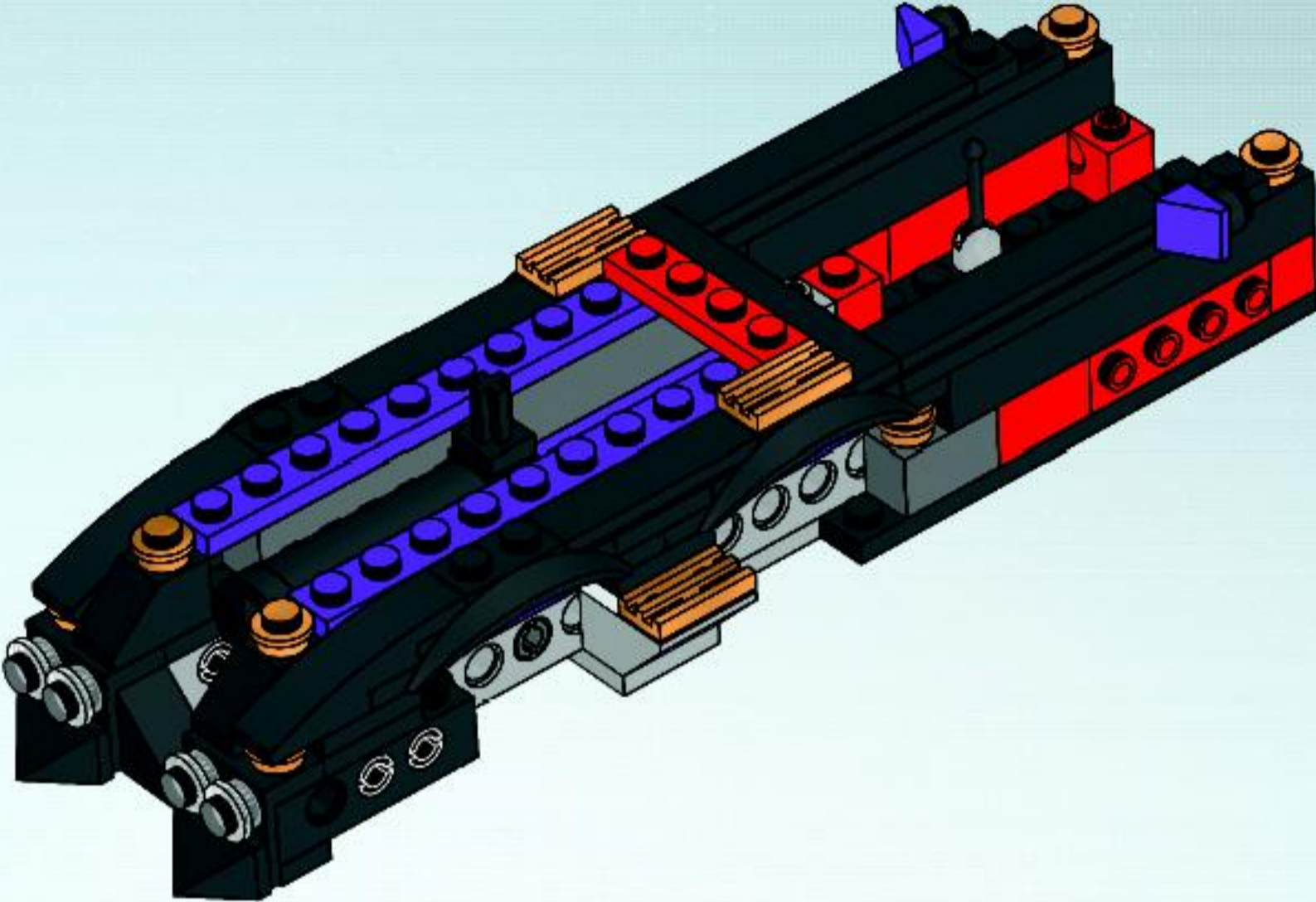

25

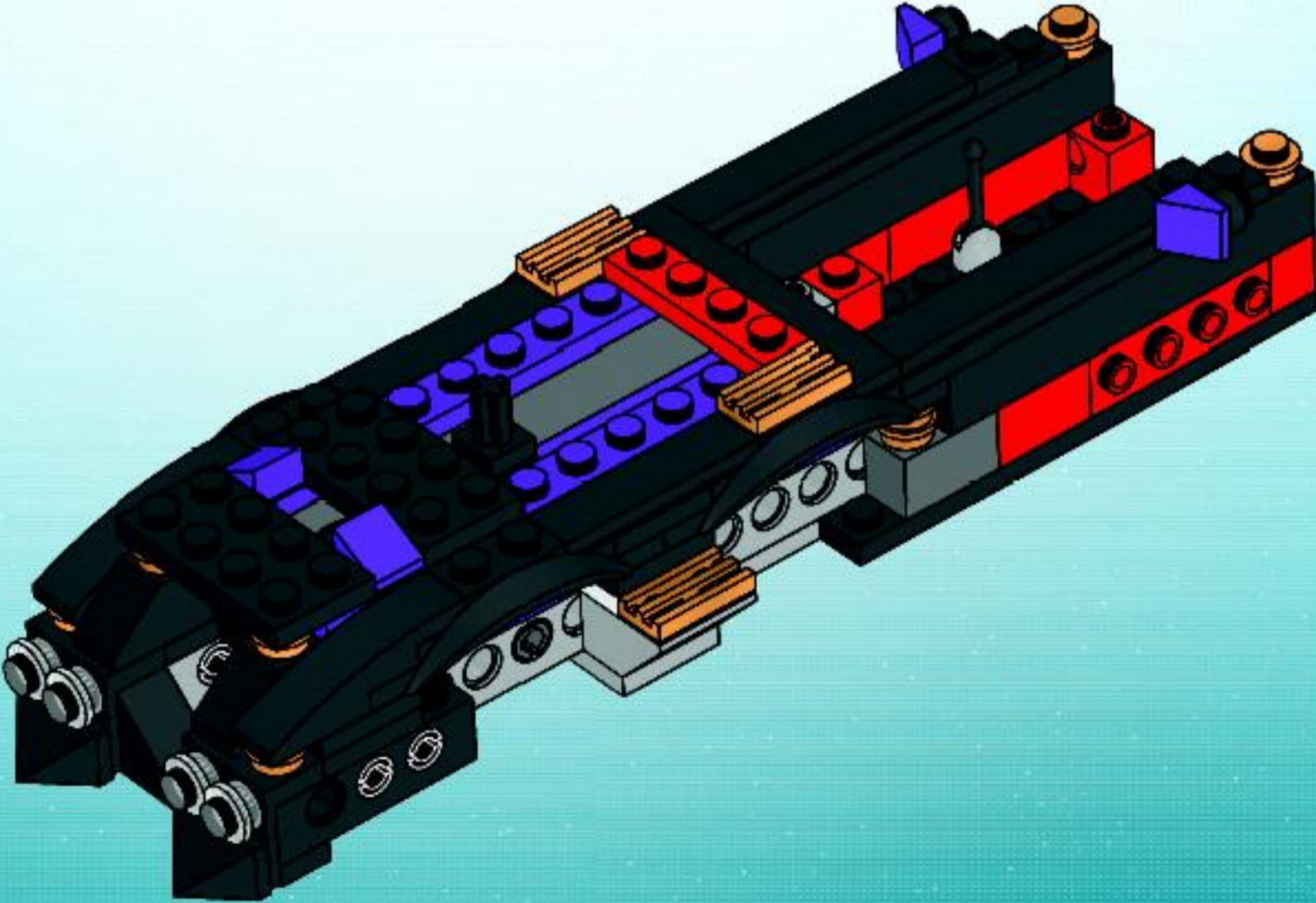



26

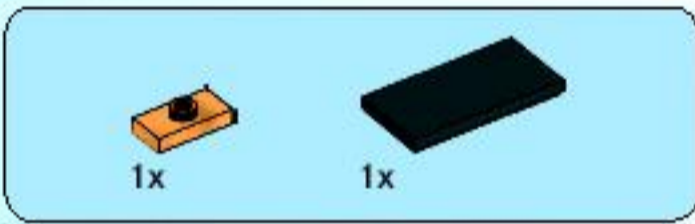
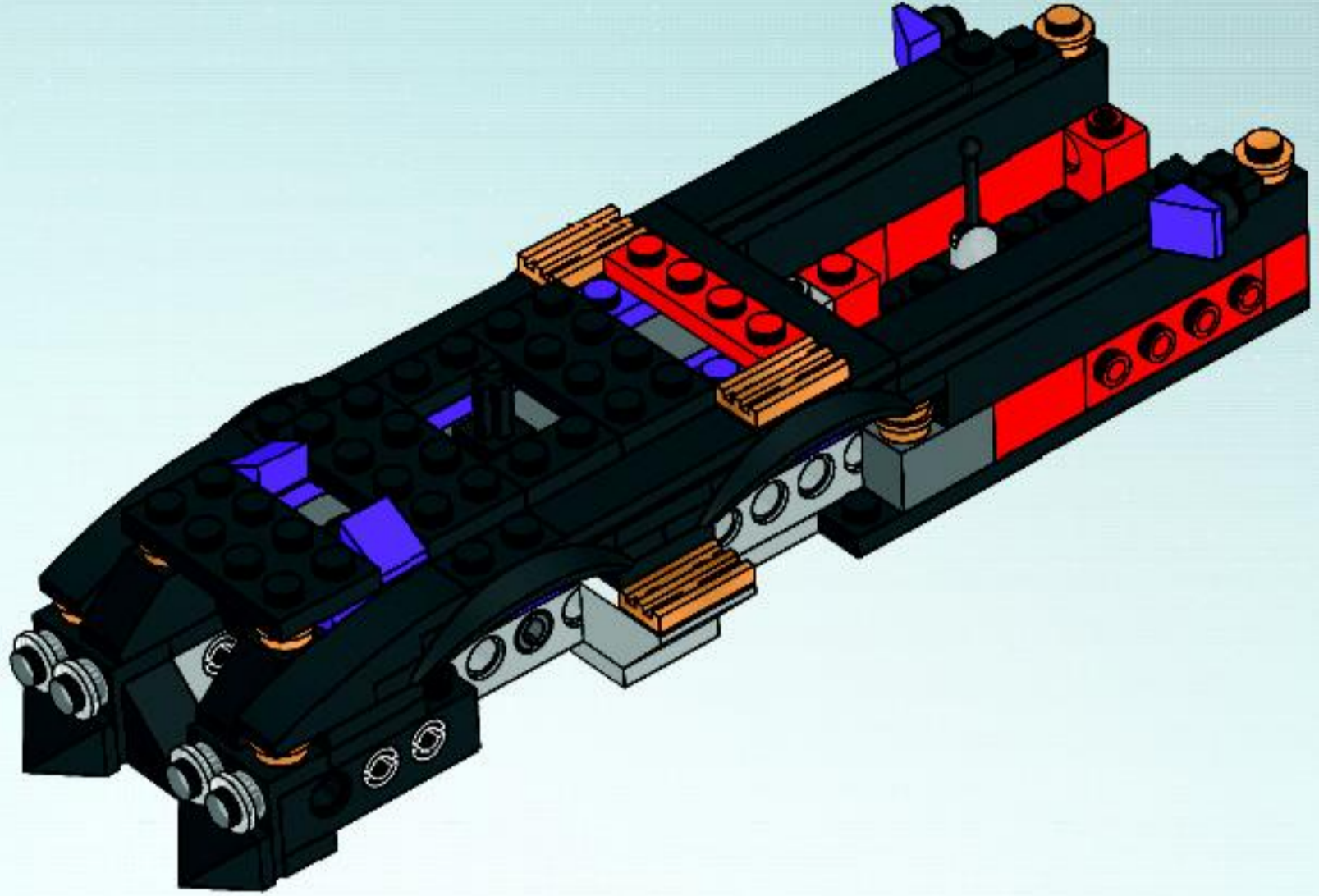

27

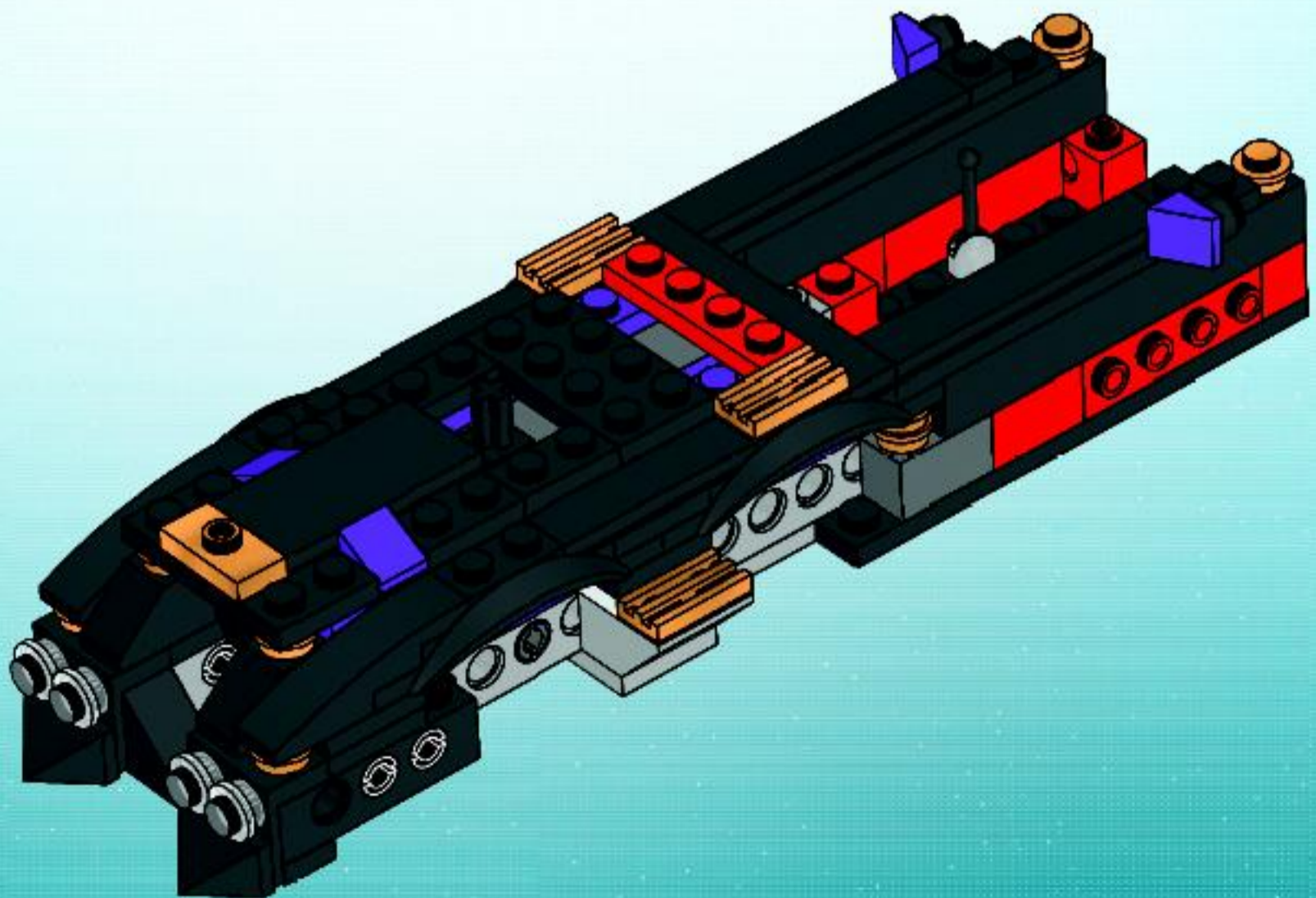

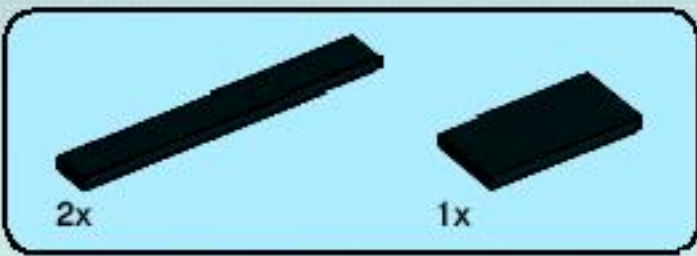

28

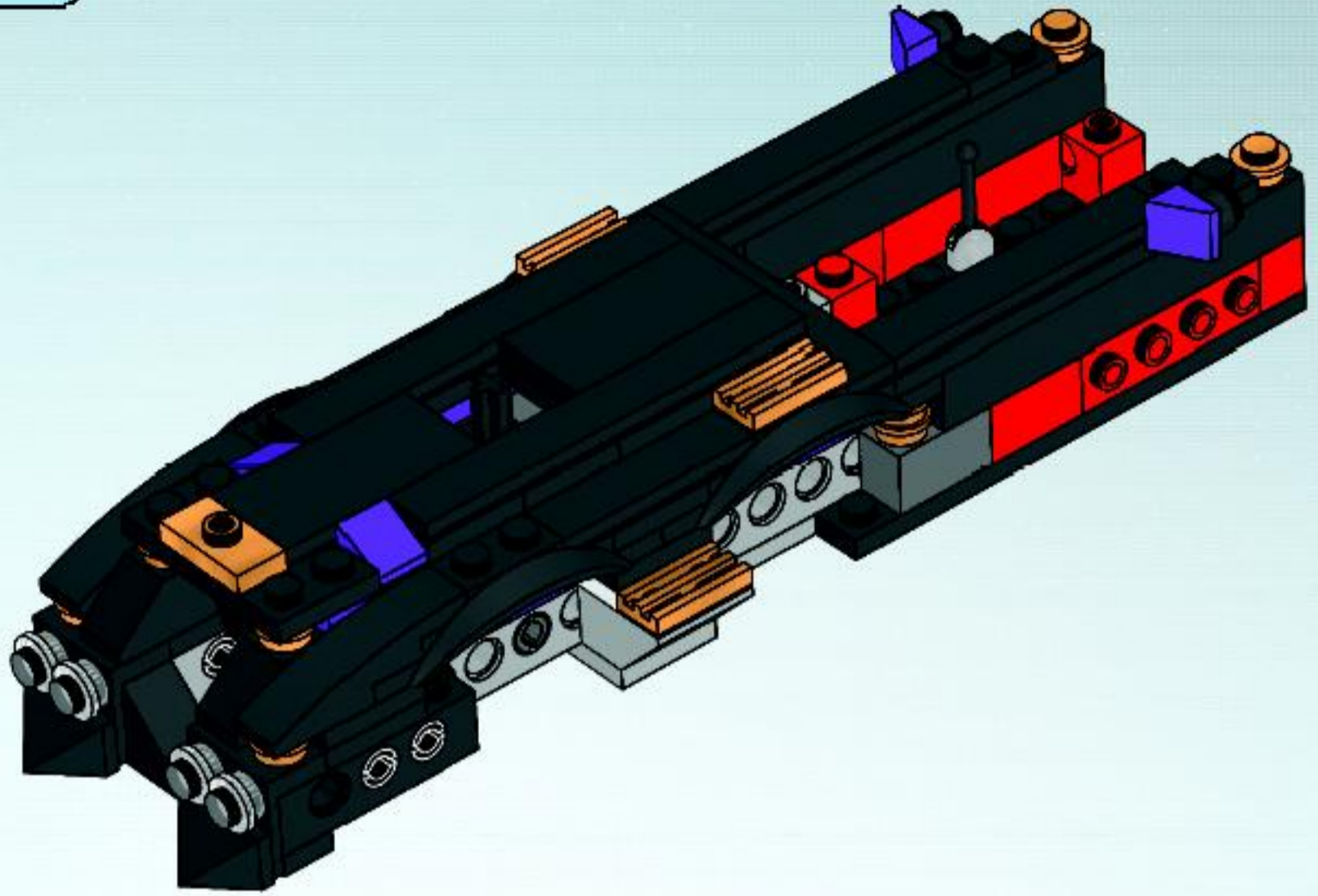

29

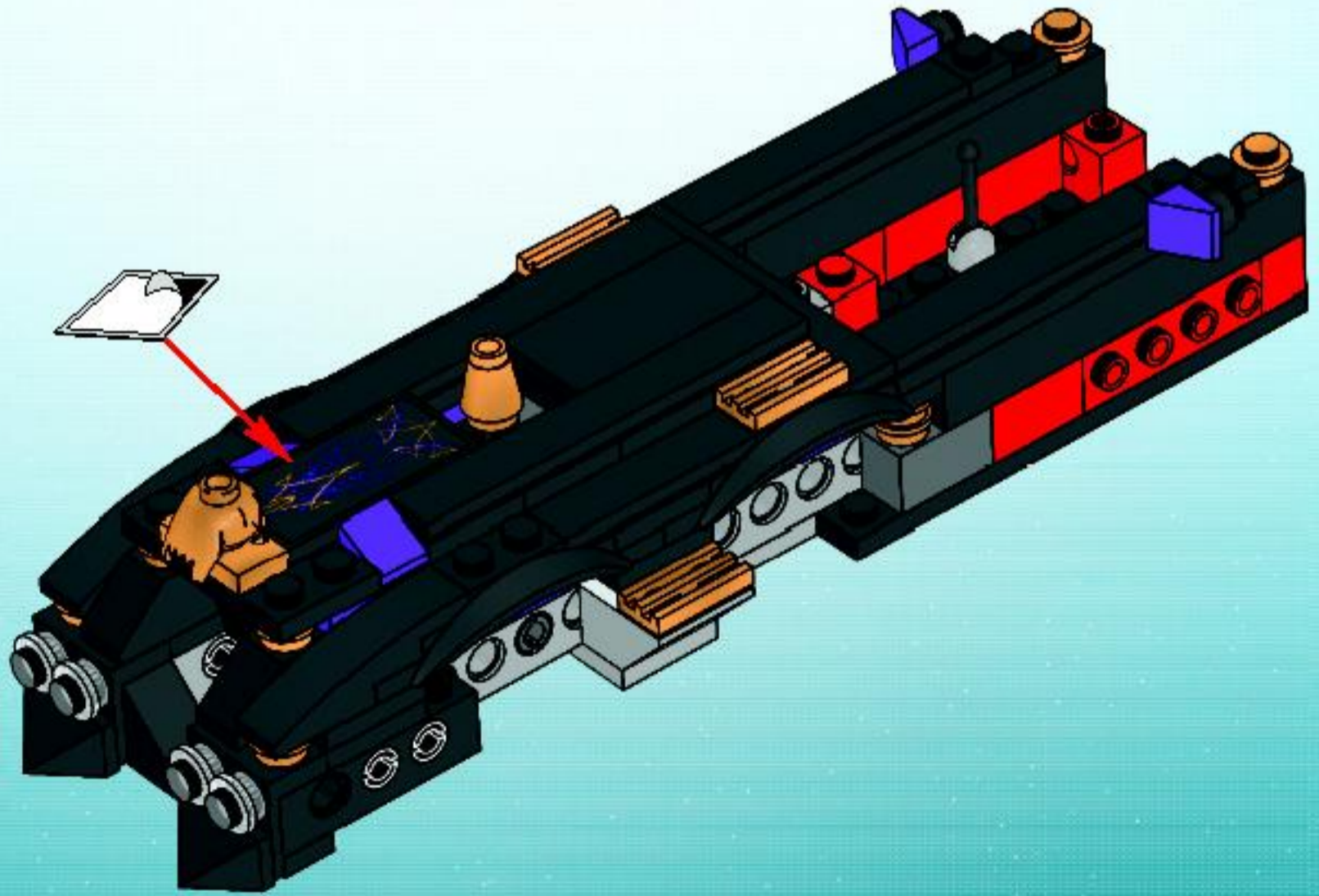

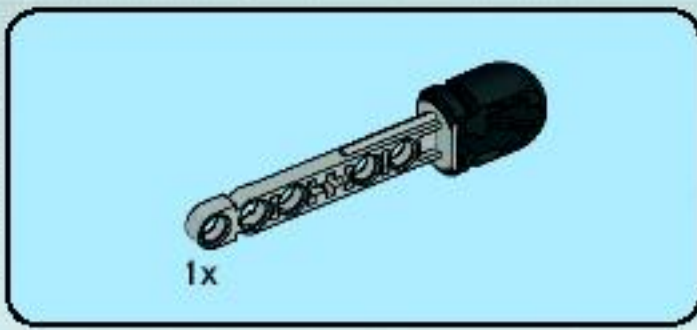

30

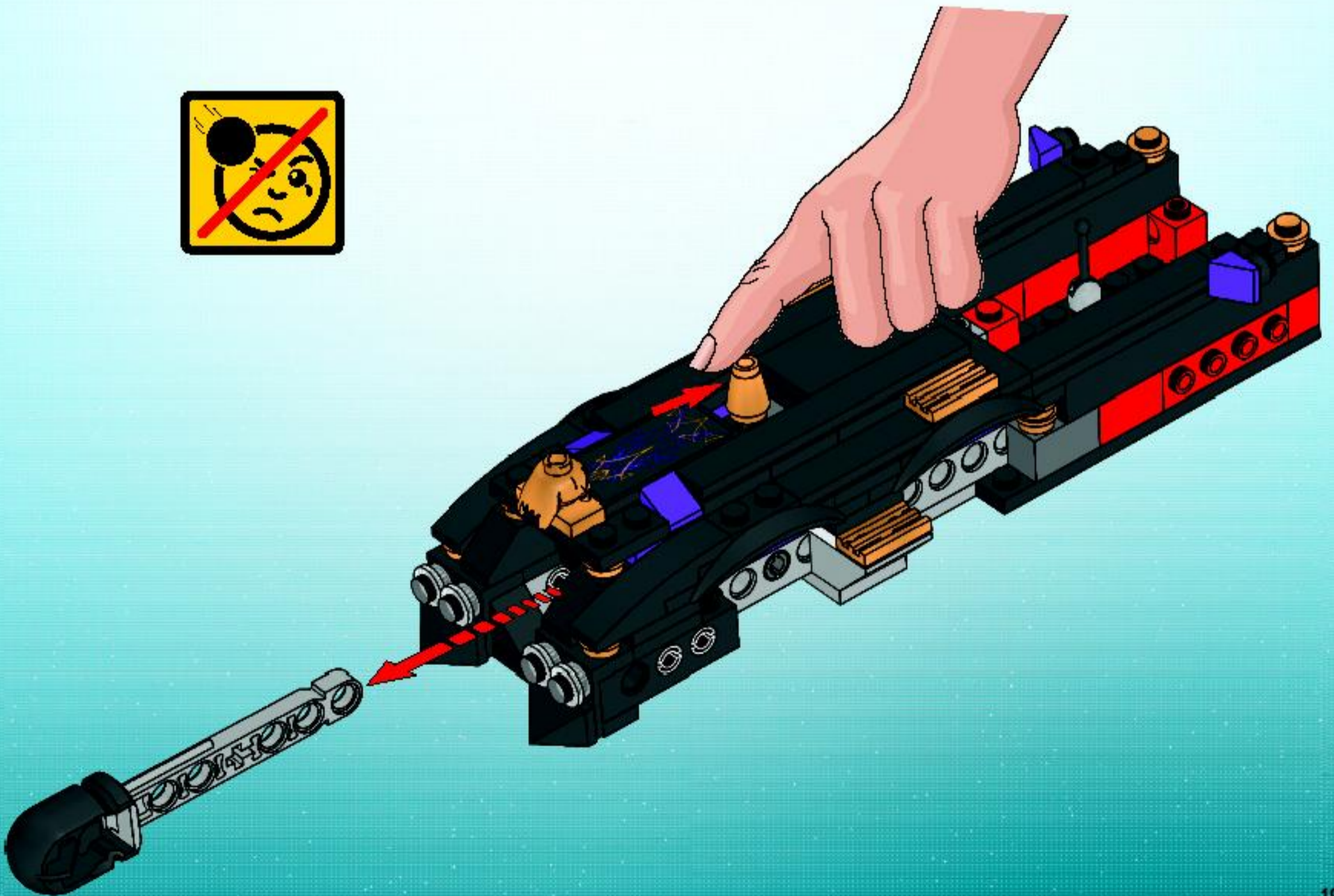
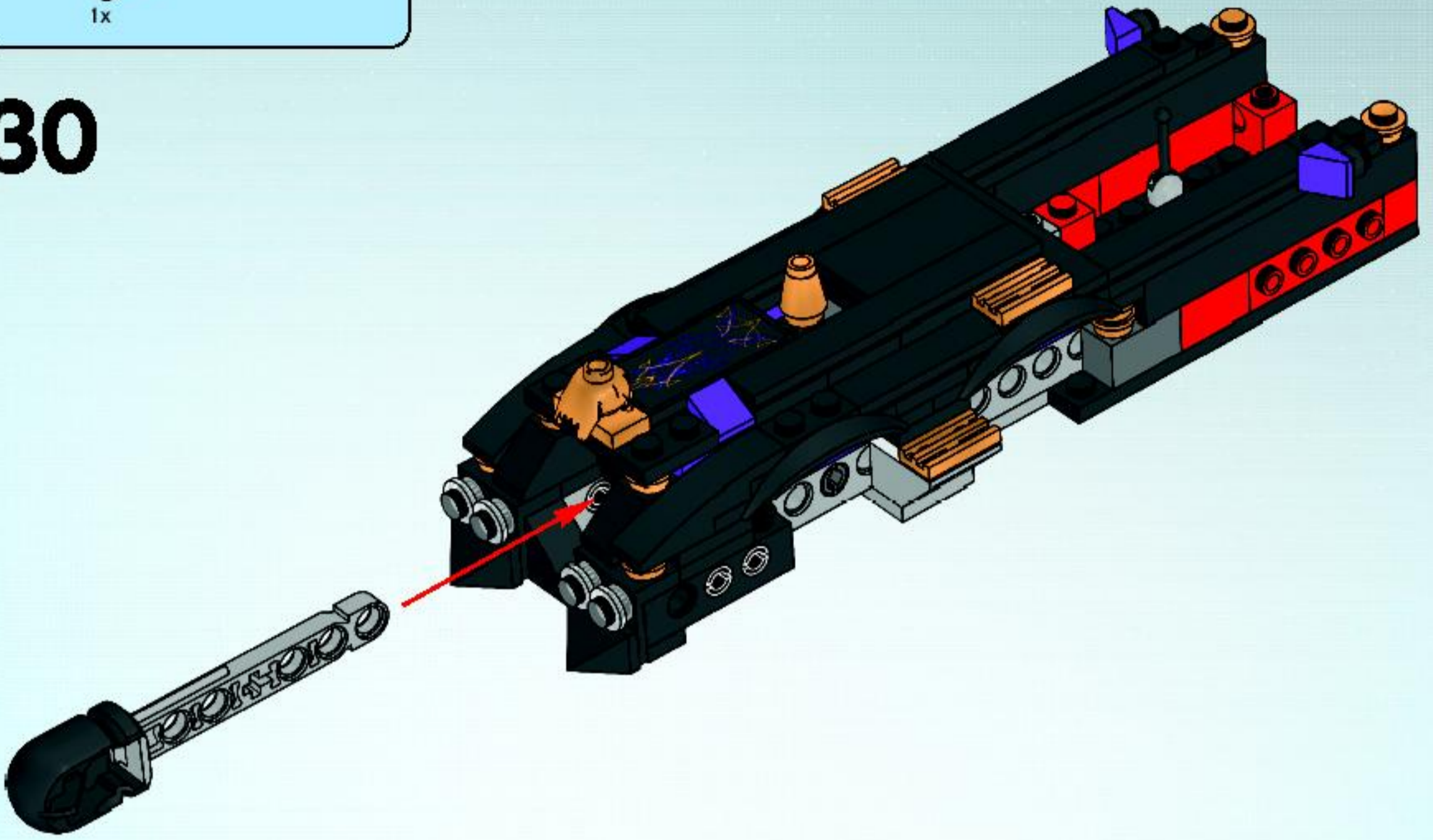

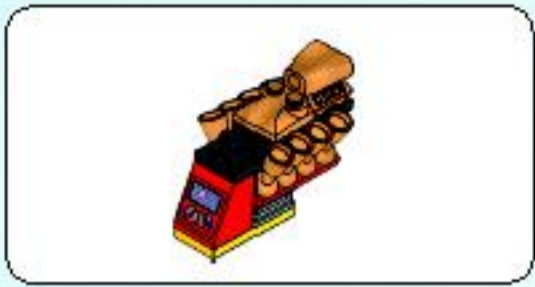
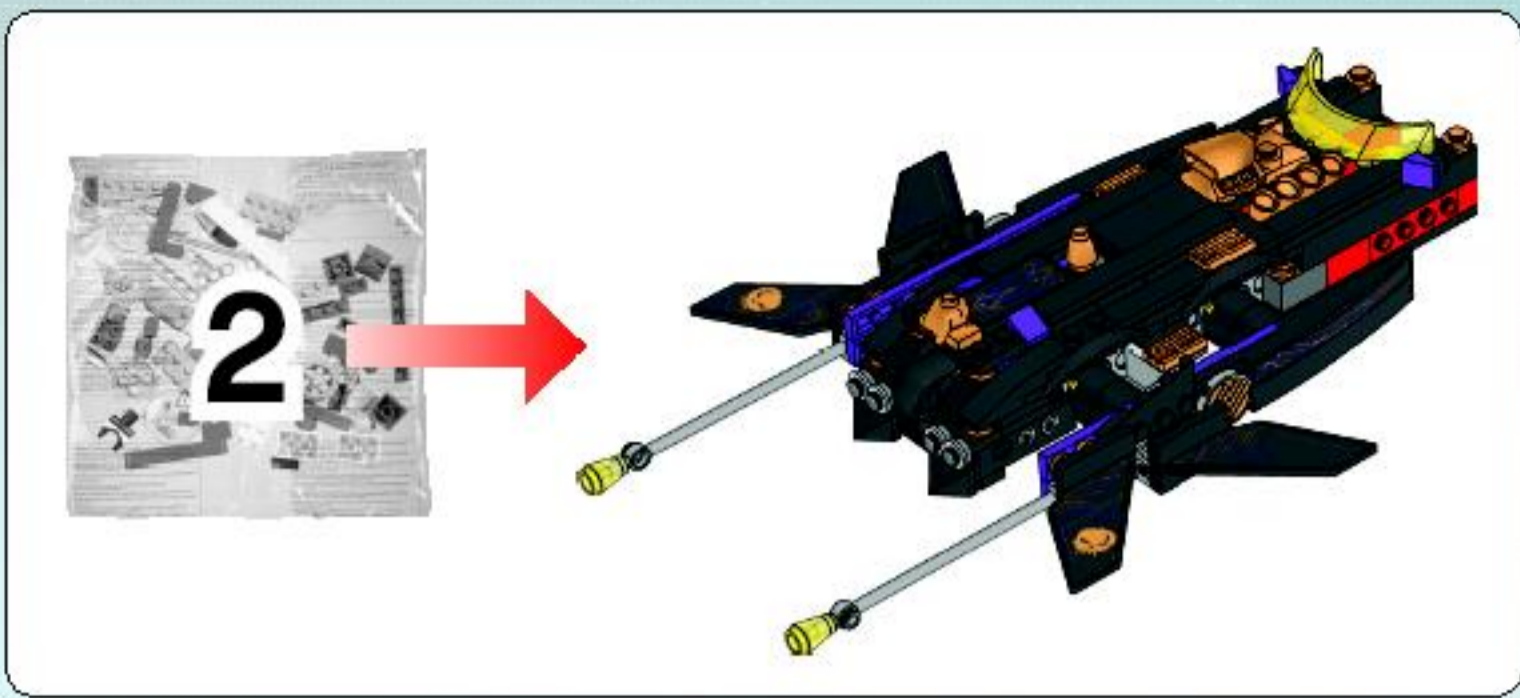

1

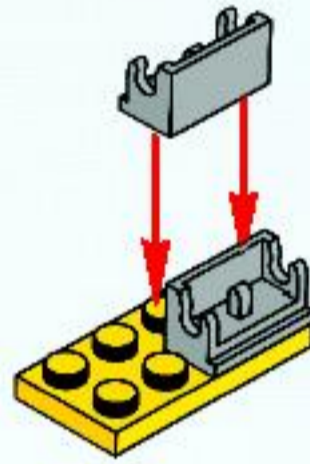

2

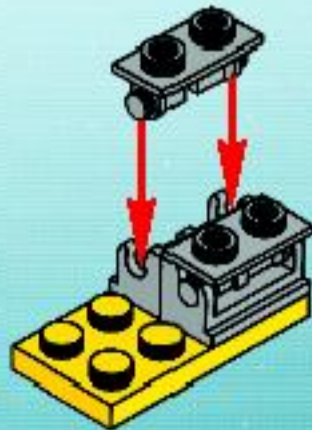

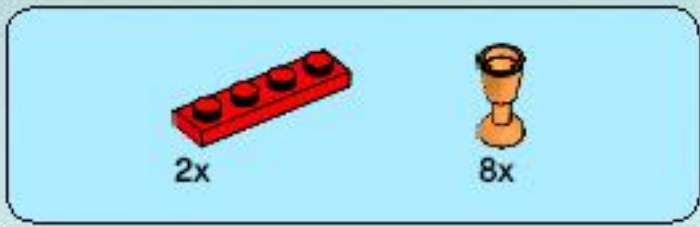

3

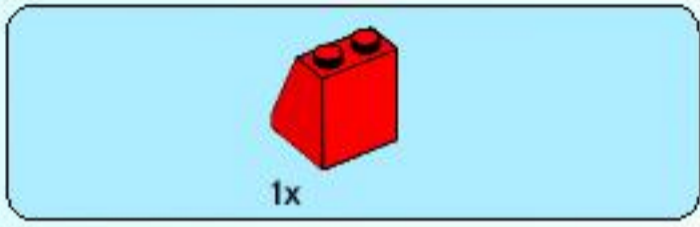
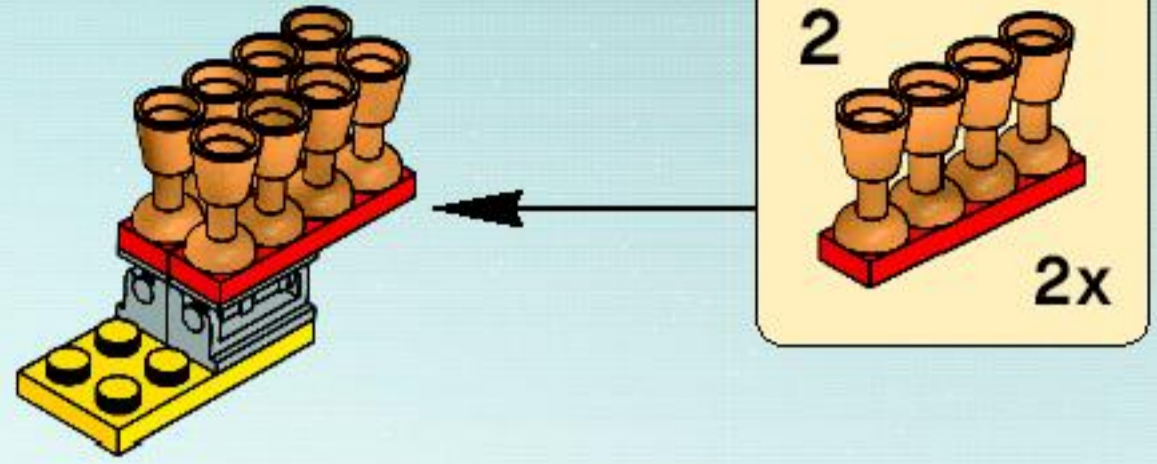

4

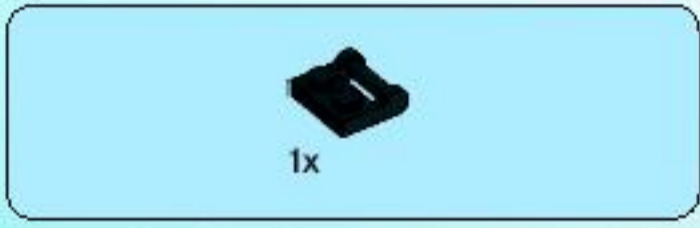

5

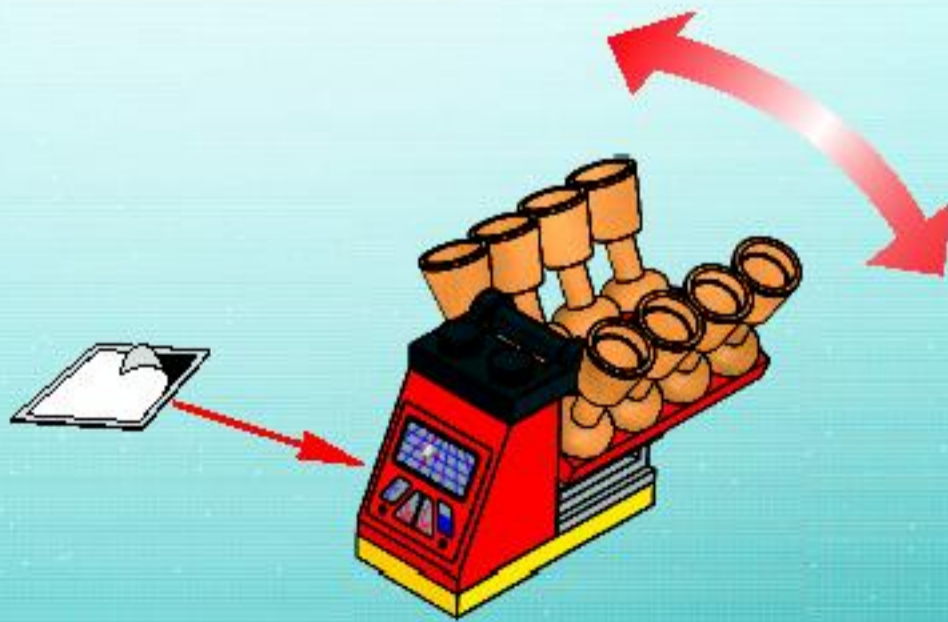

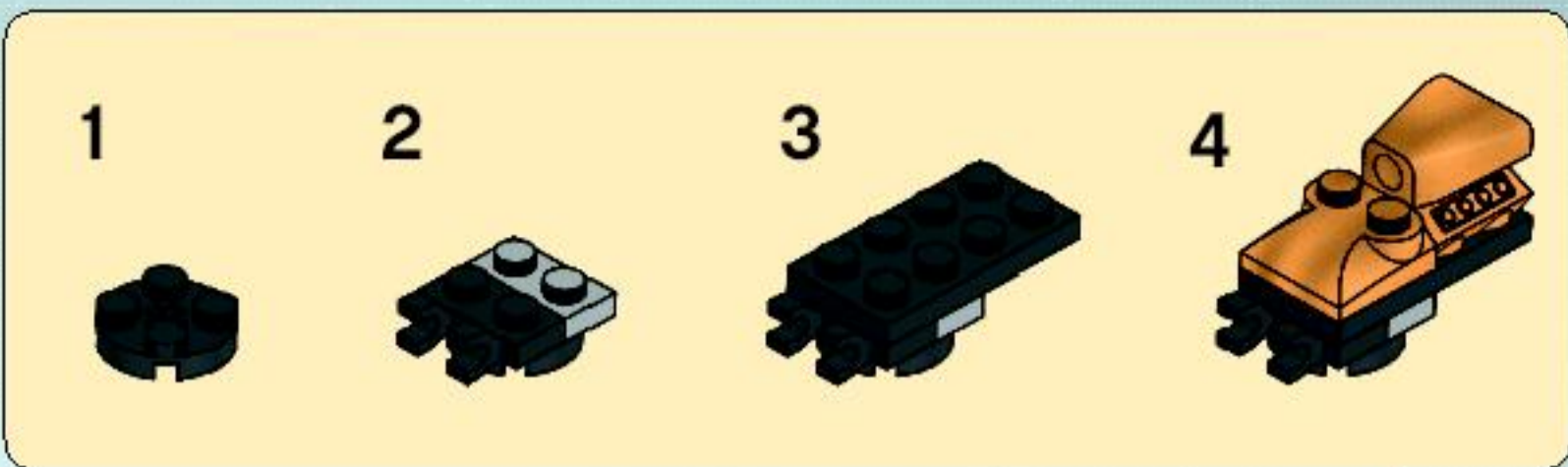
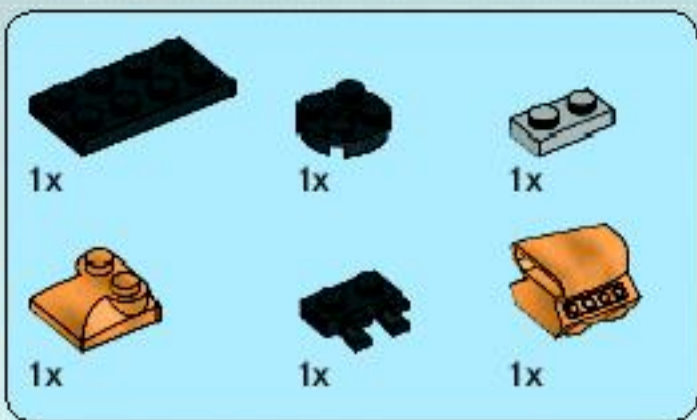

6

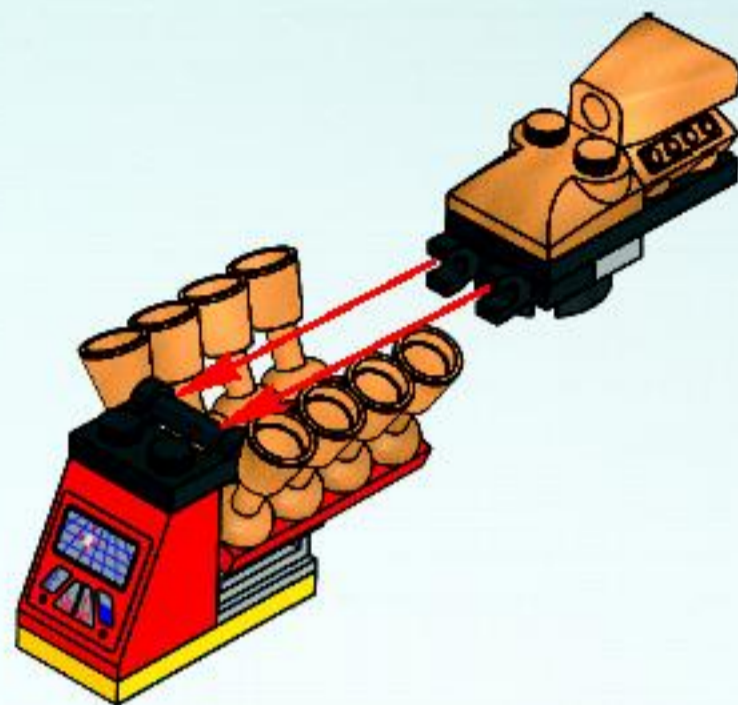

31

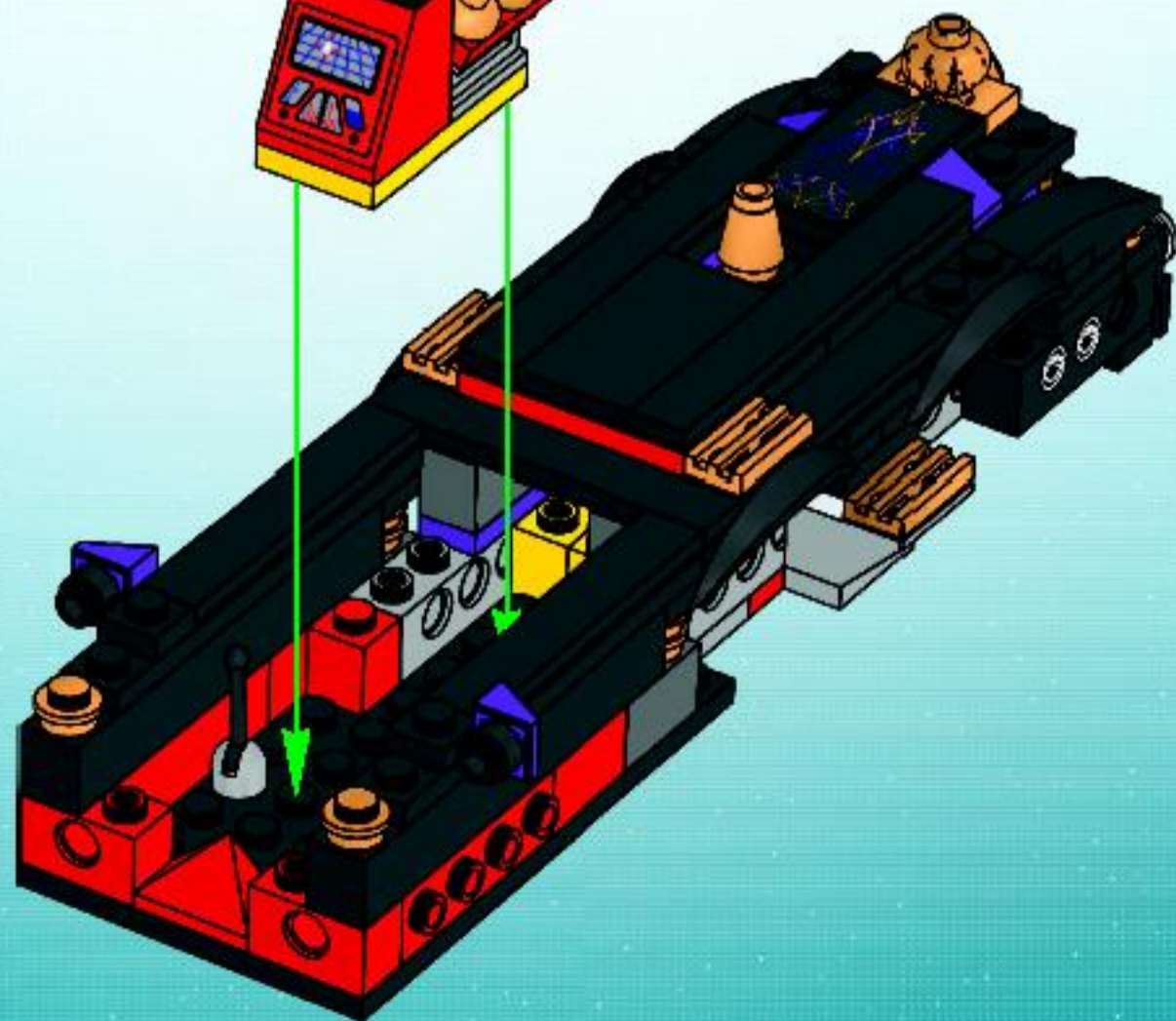

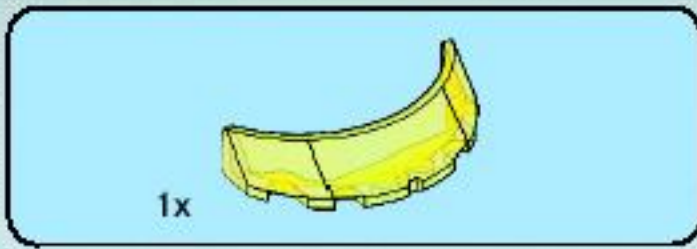

32

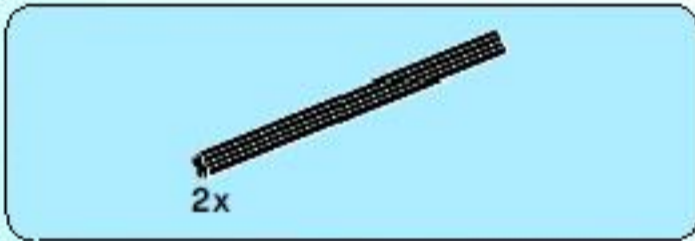
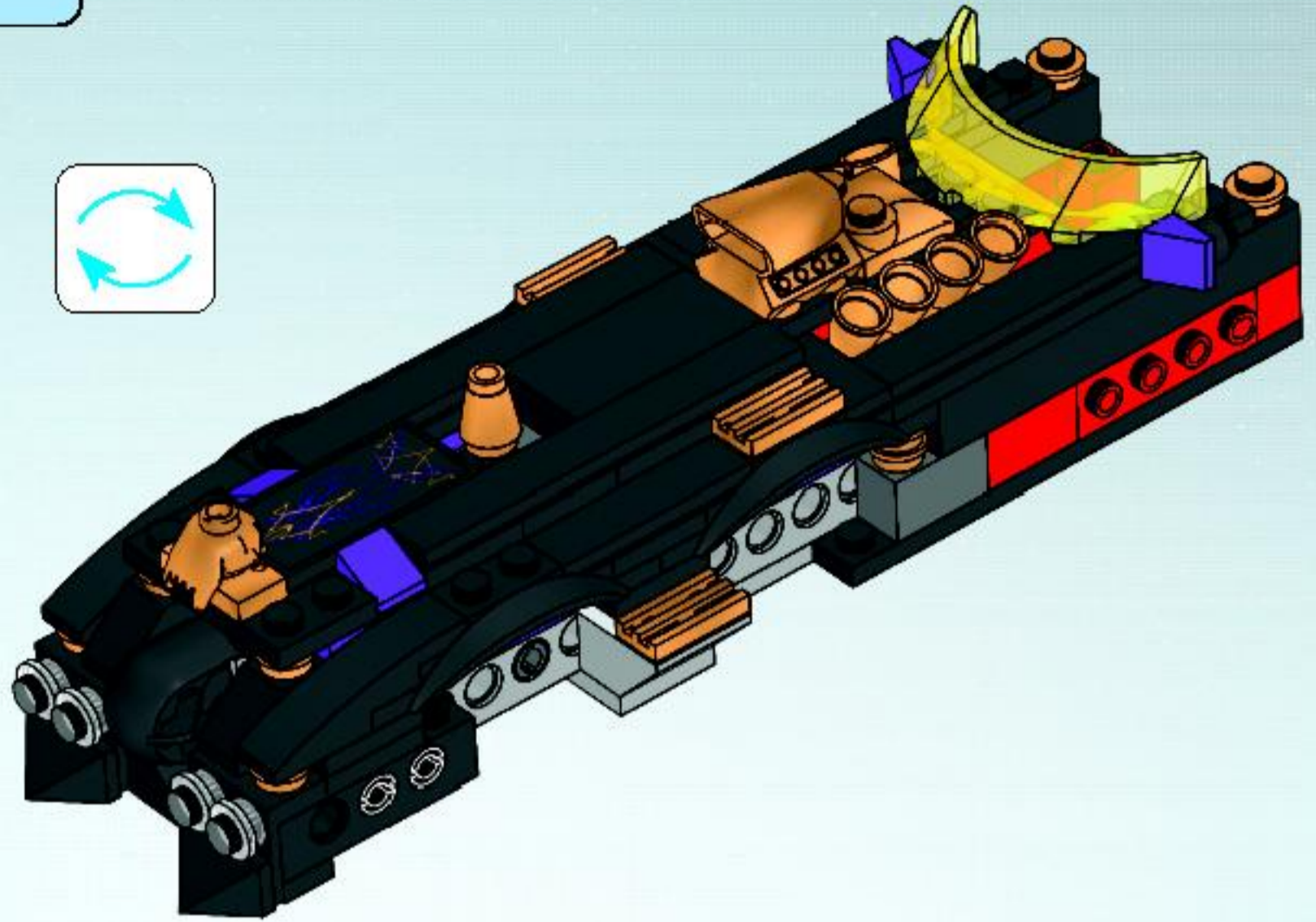

33

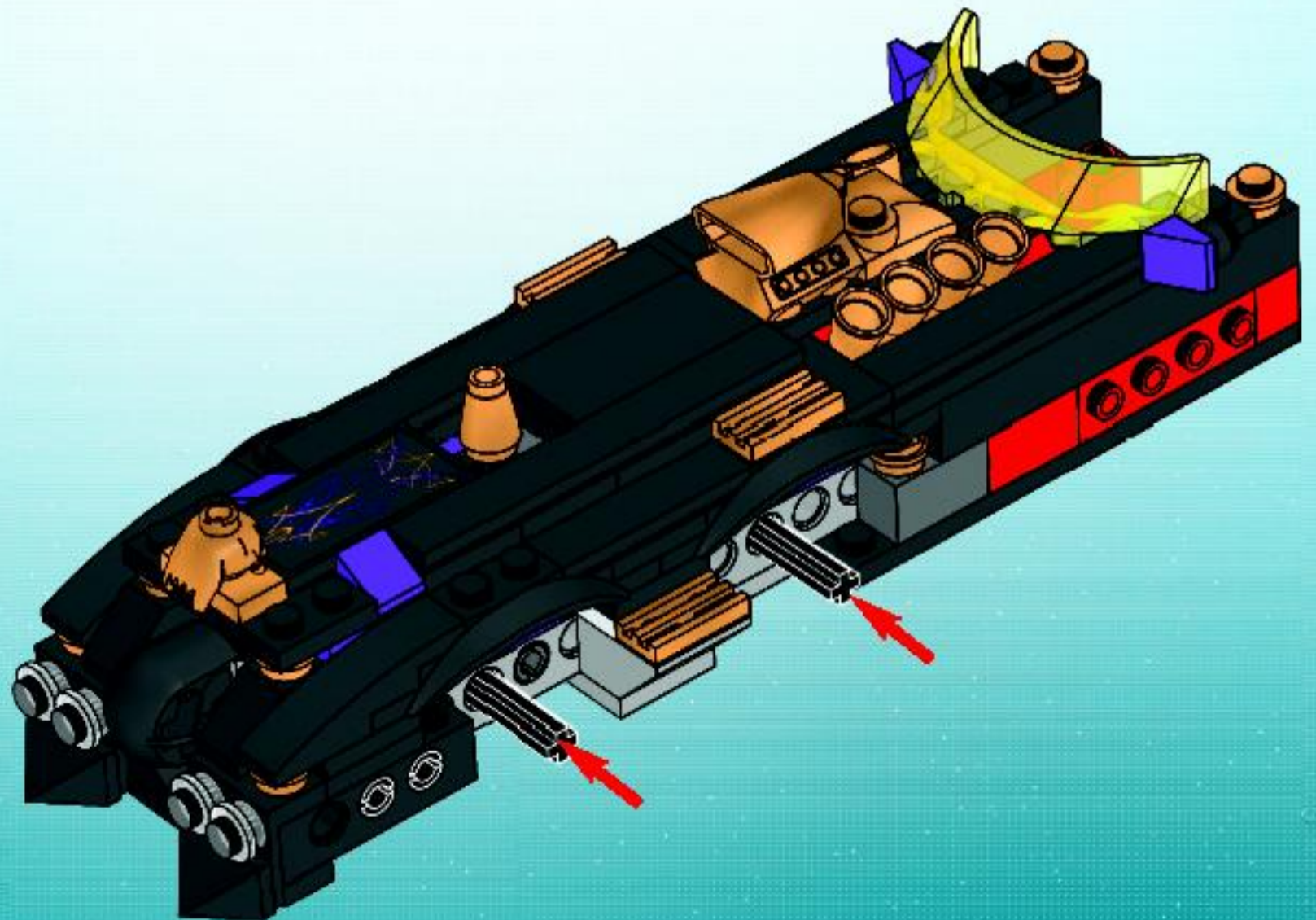



34

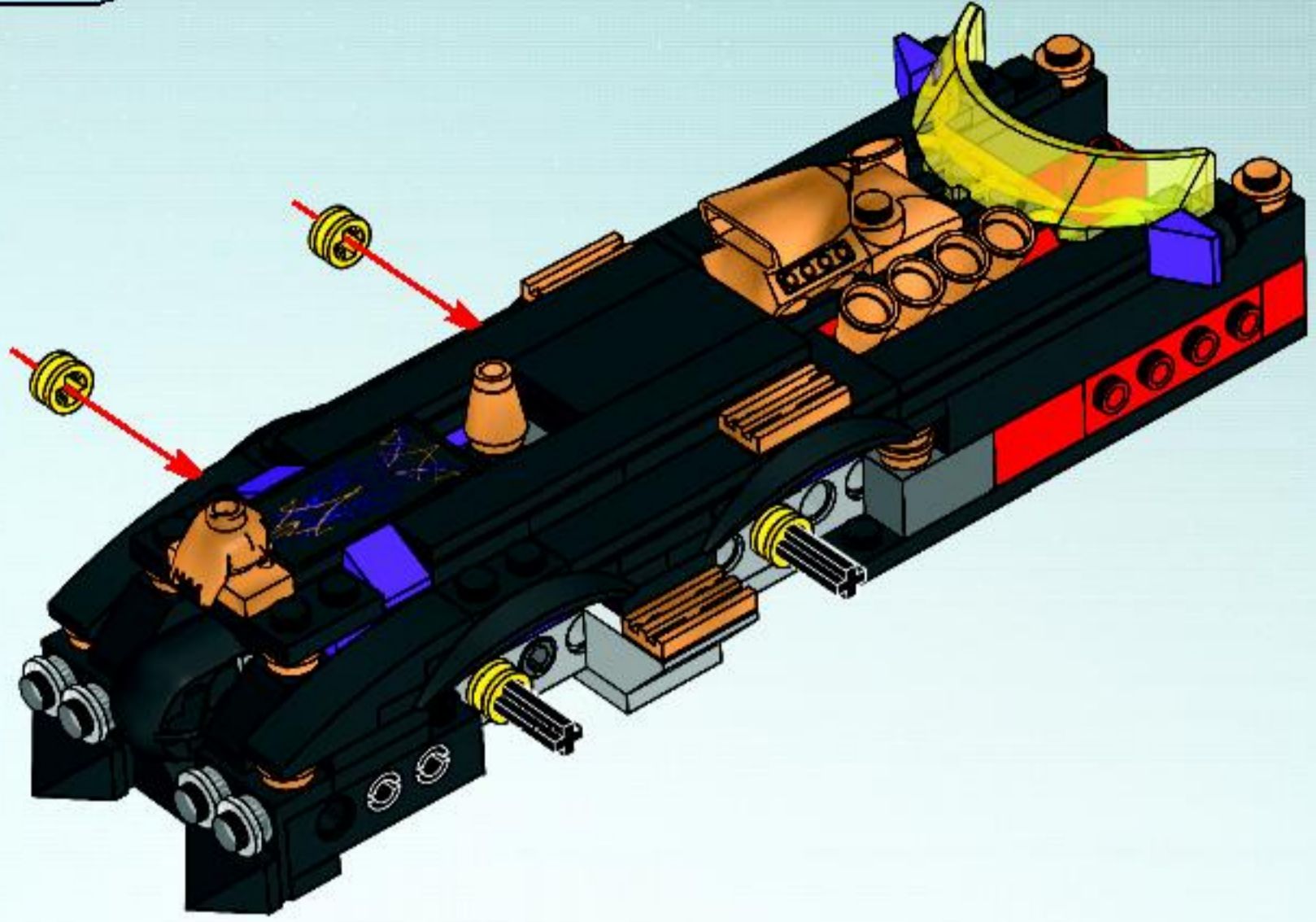

35

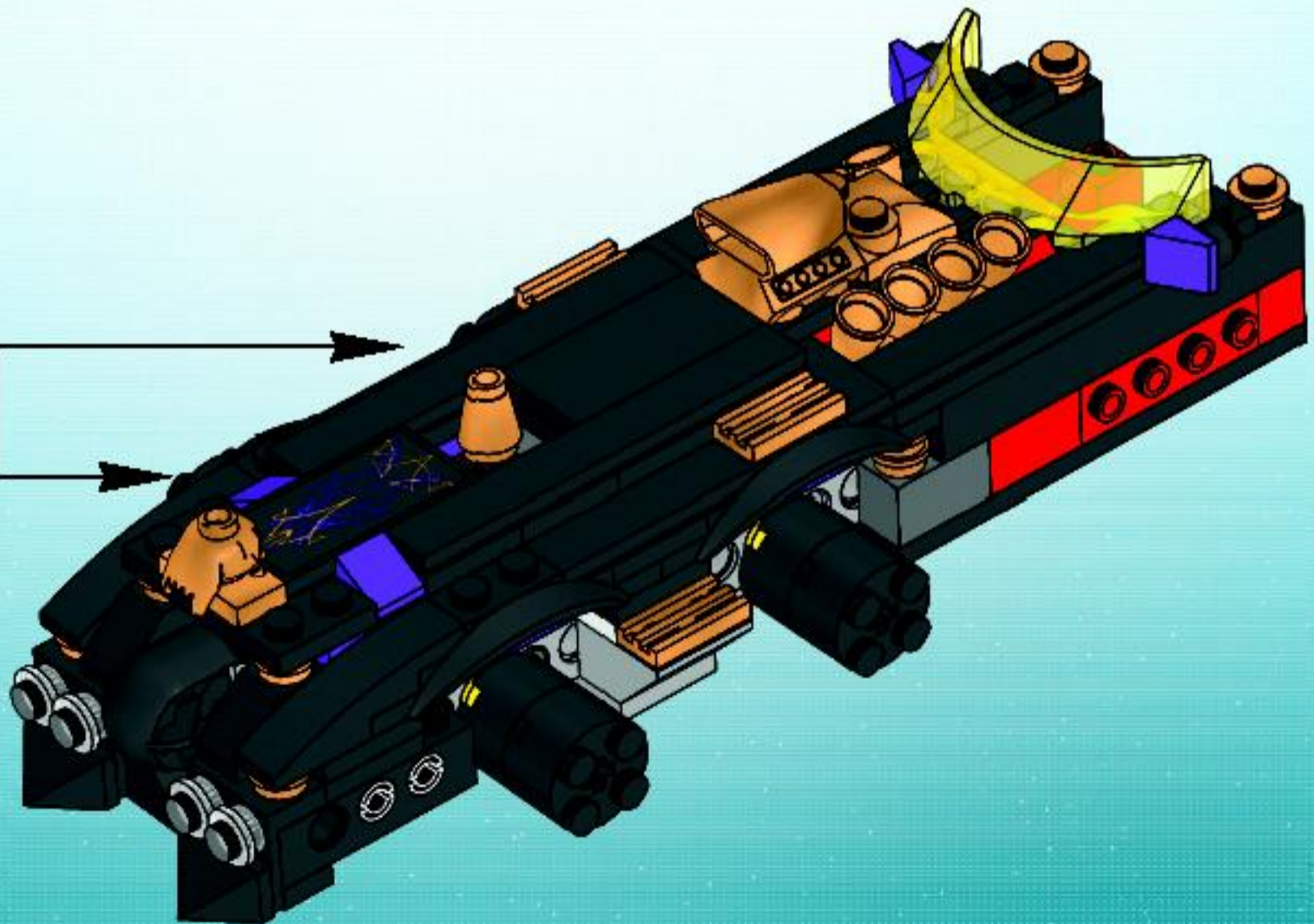

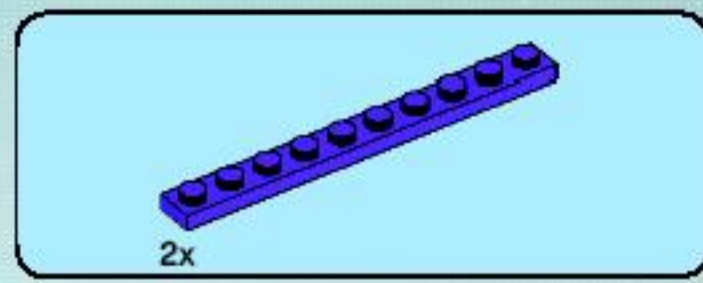
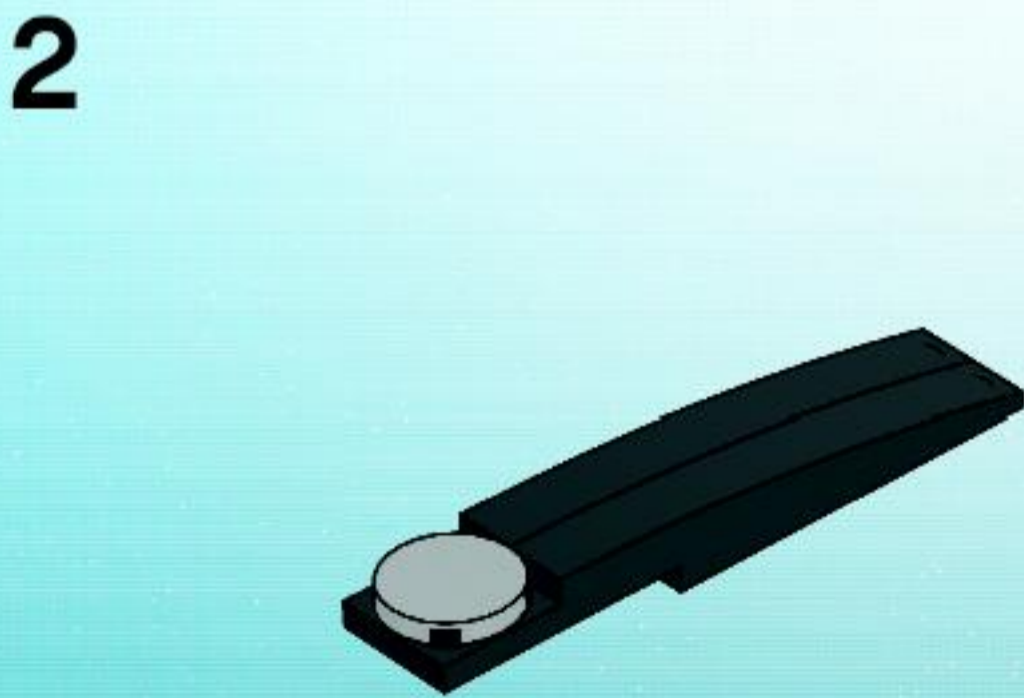
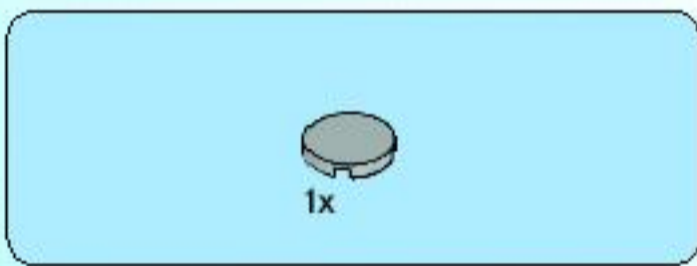
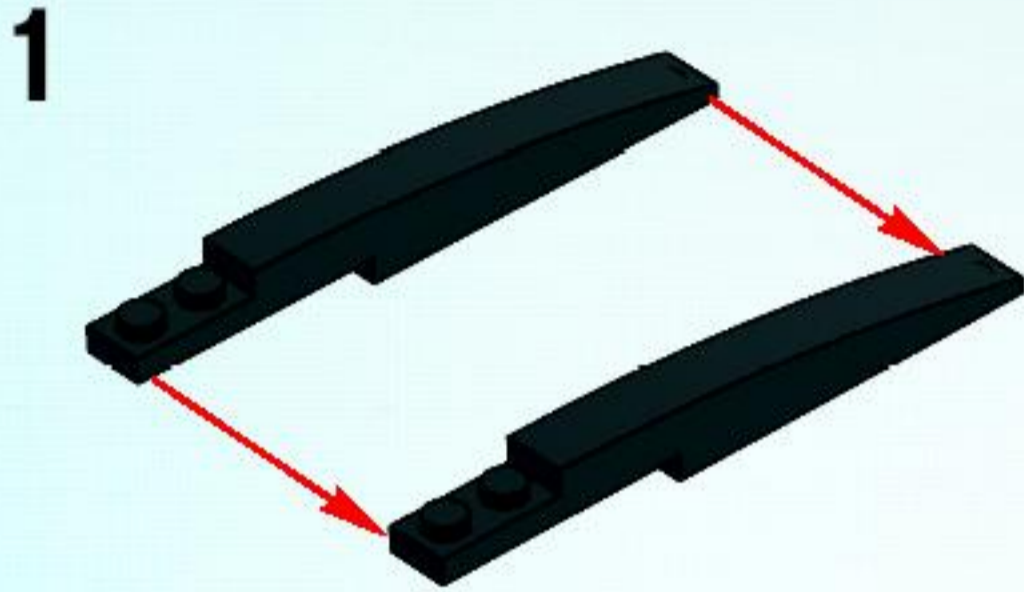
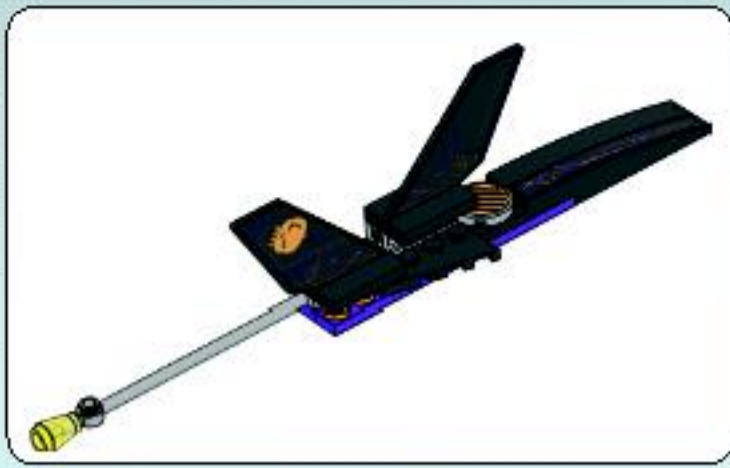

3

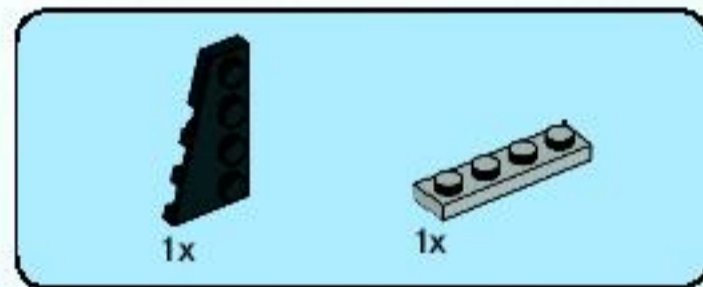
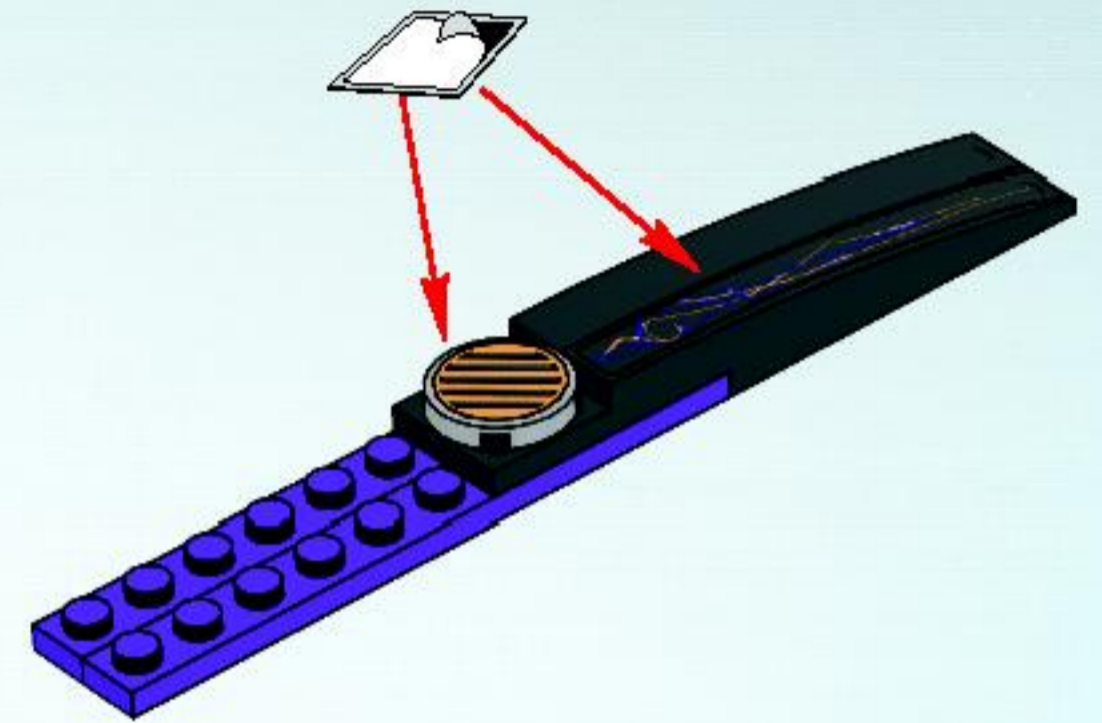

4

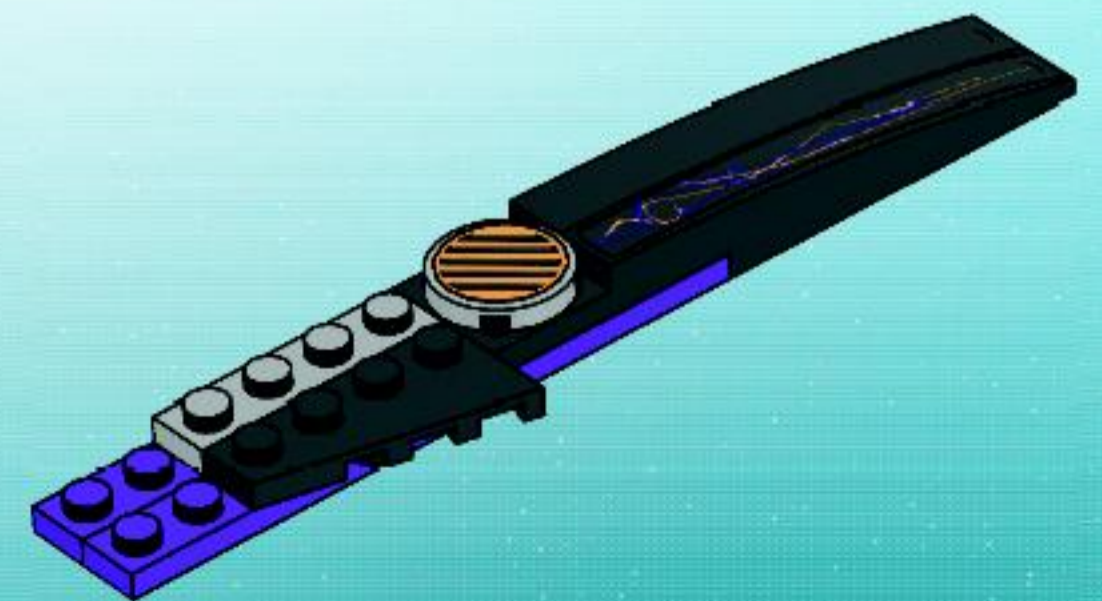

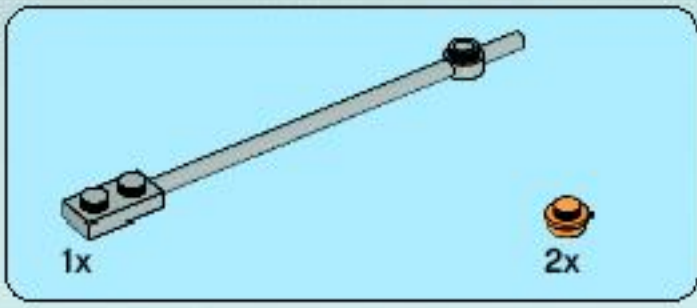

5

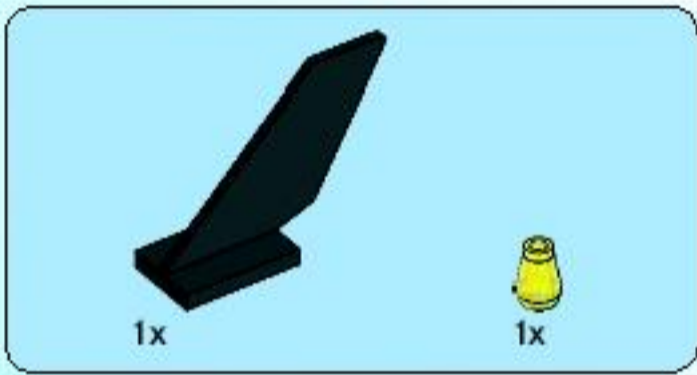
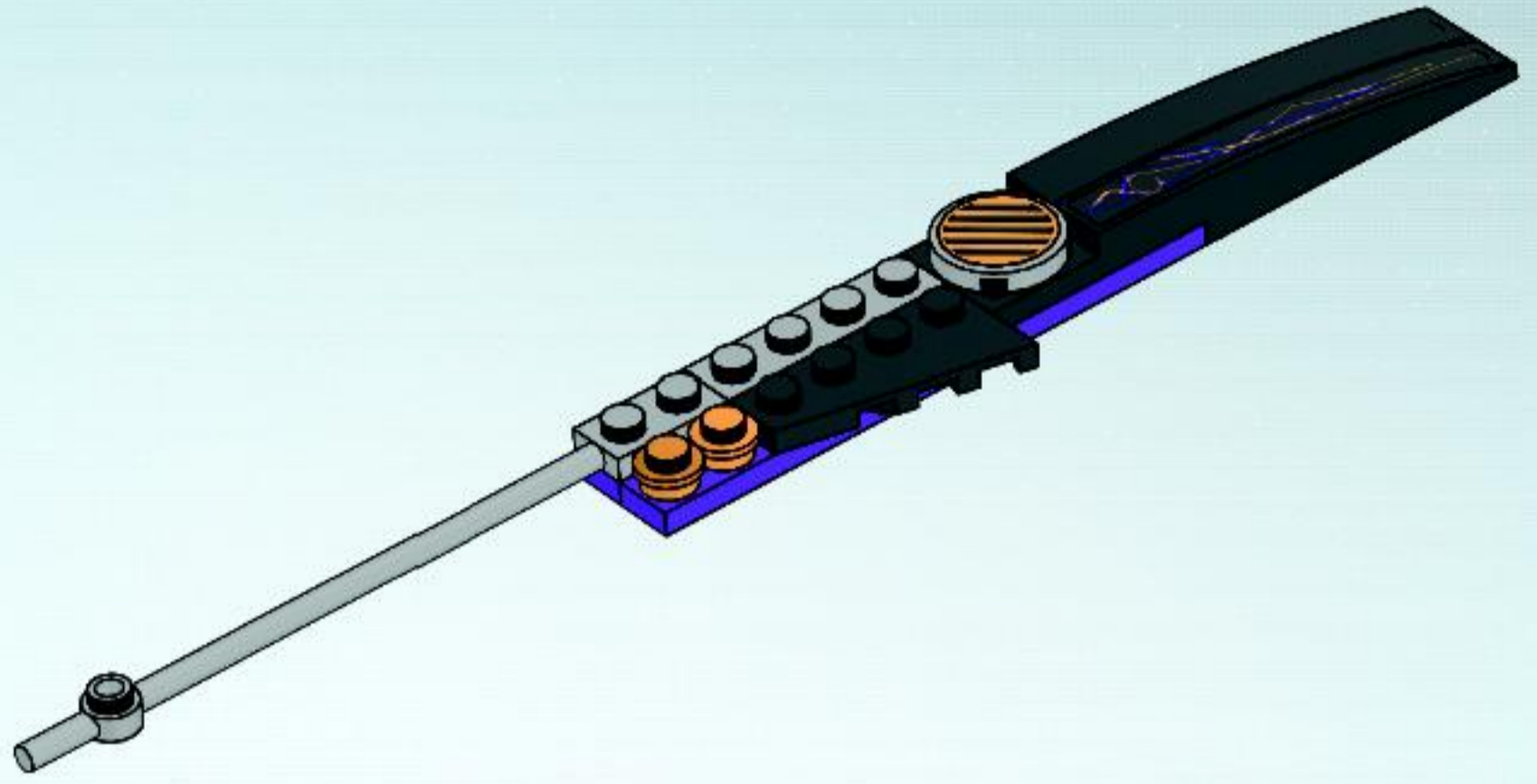

6

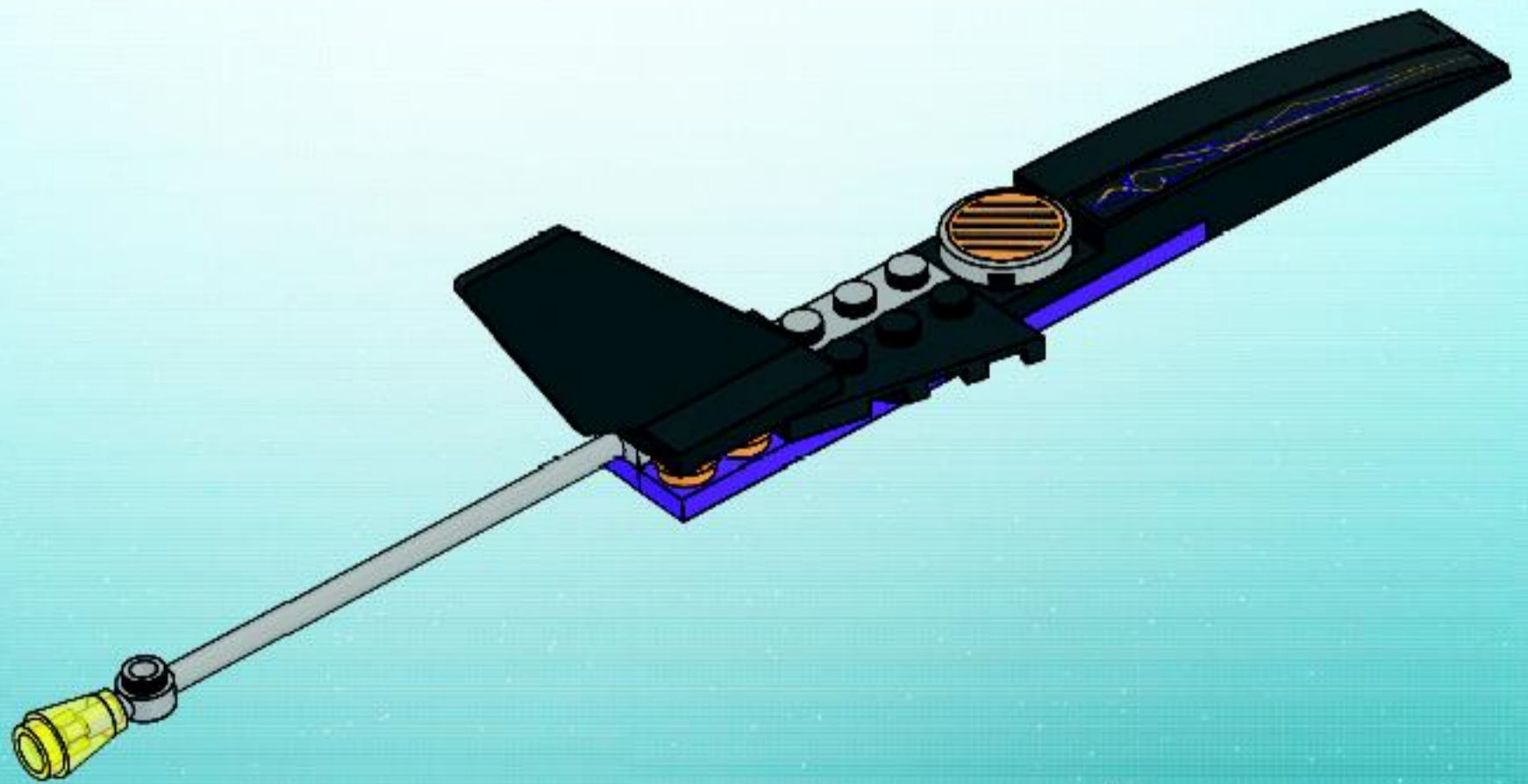



7

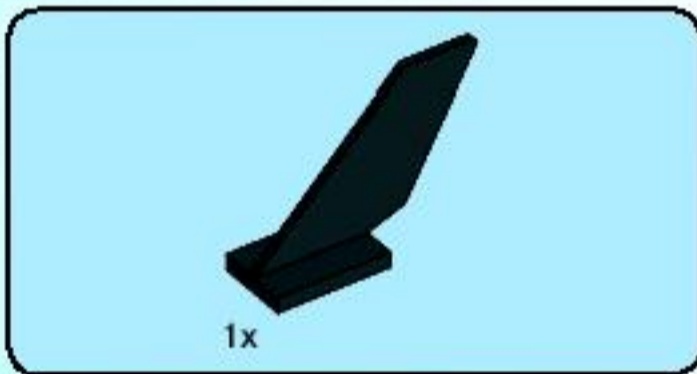
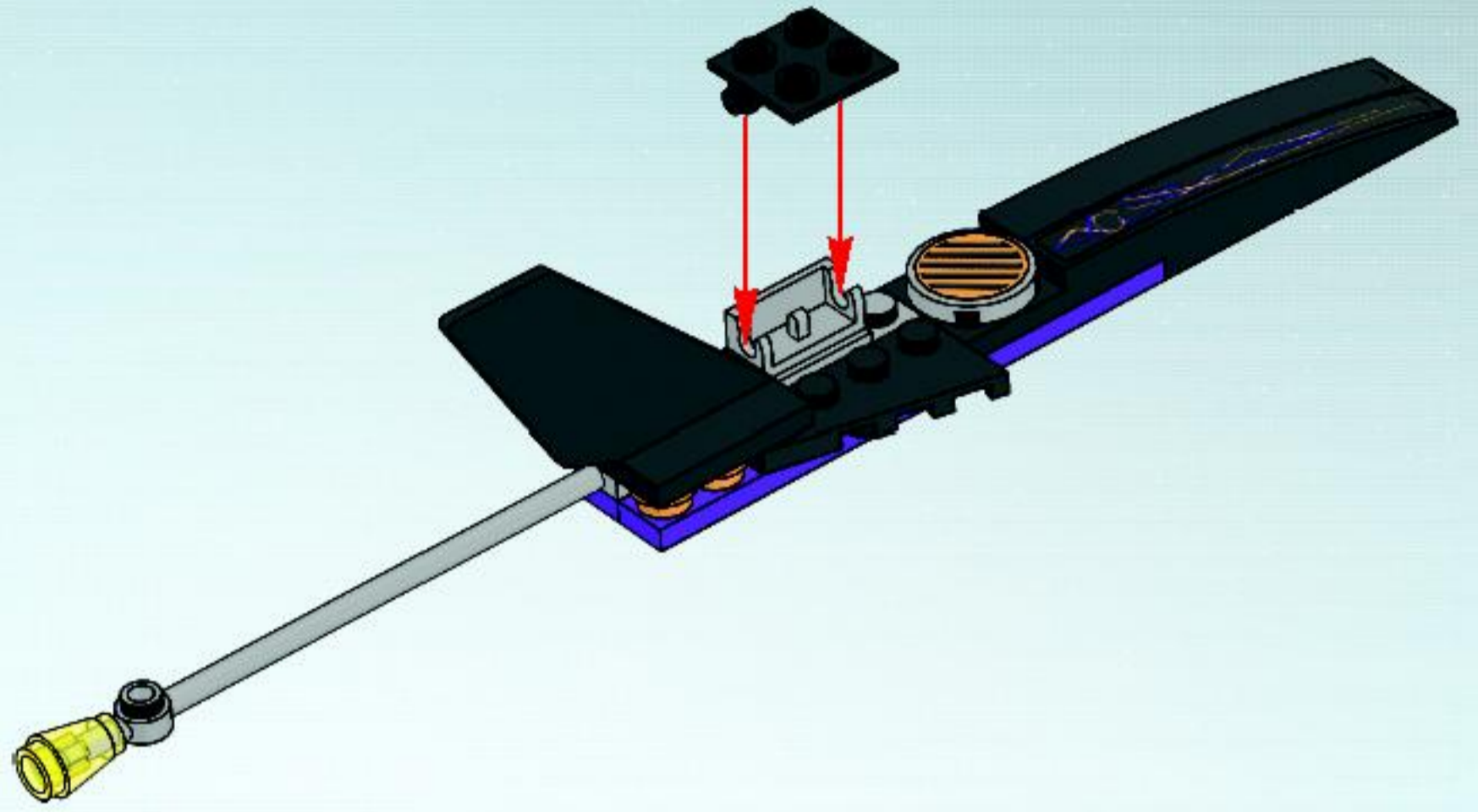

8

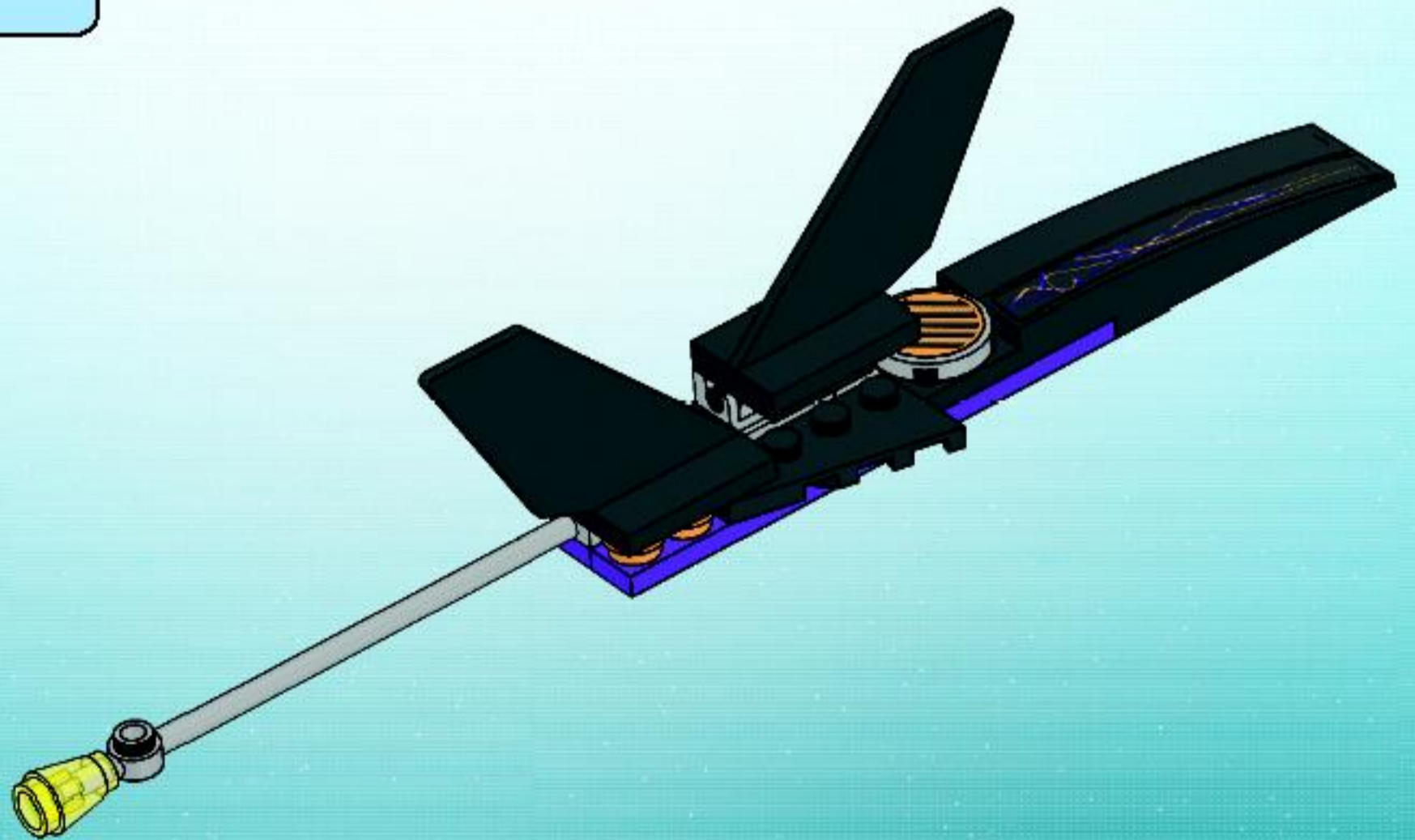

9

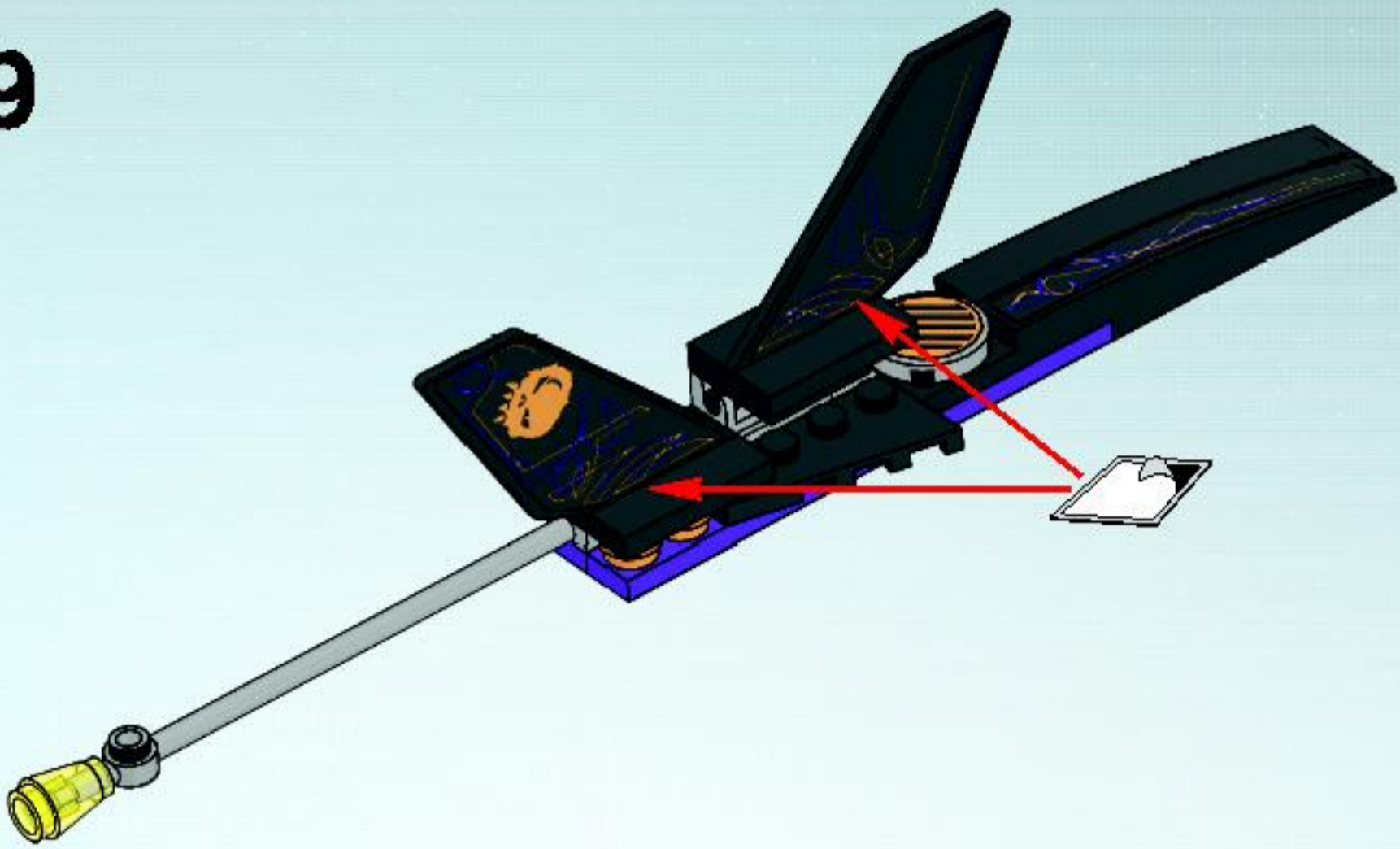

36

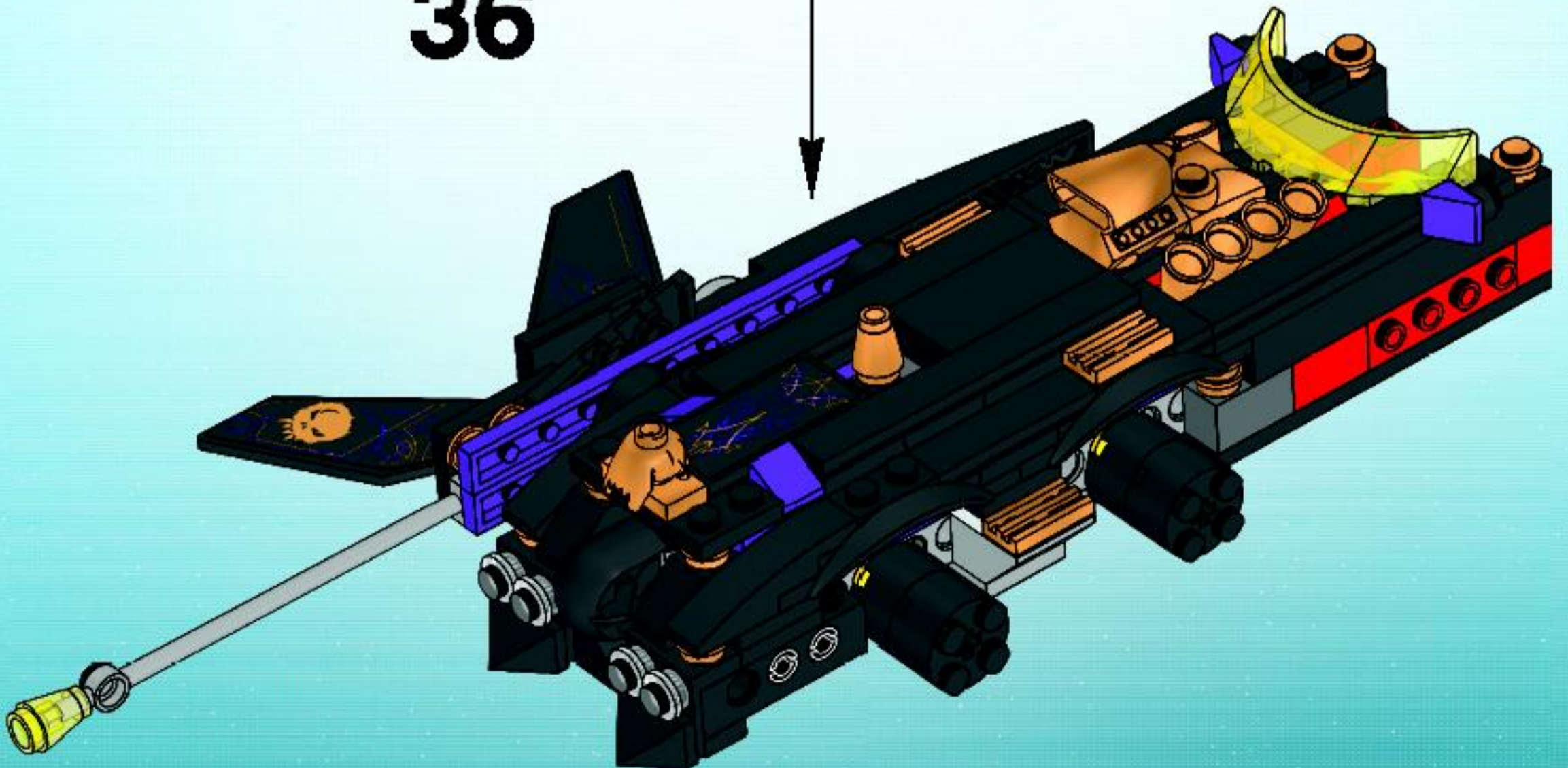



1

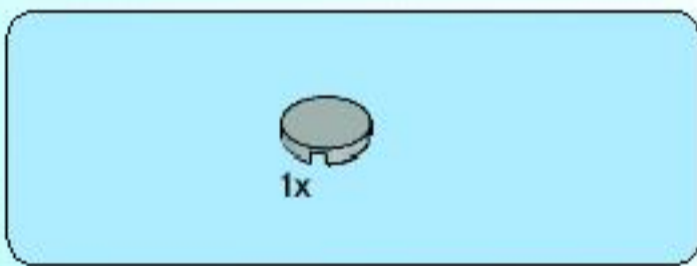
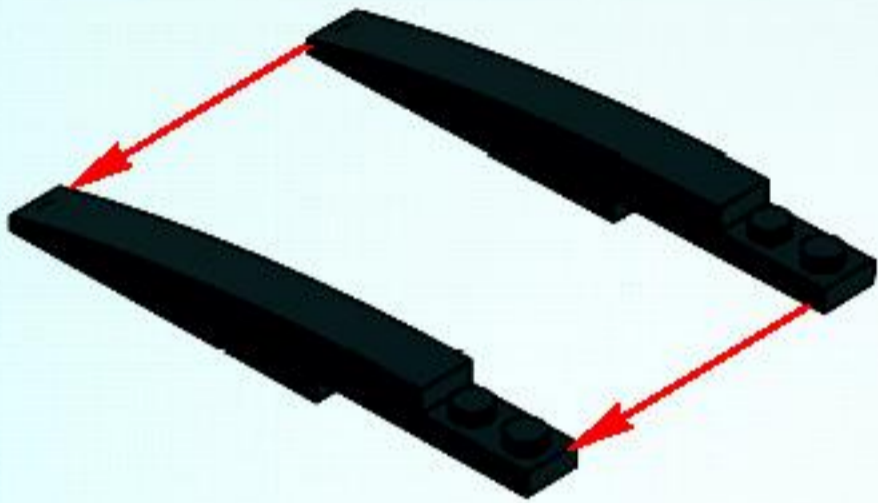

2

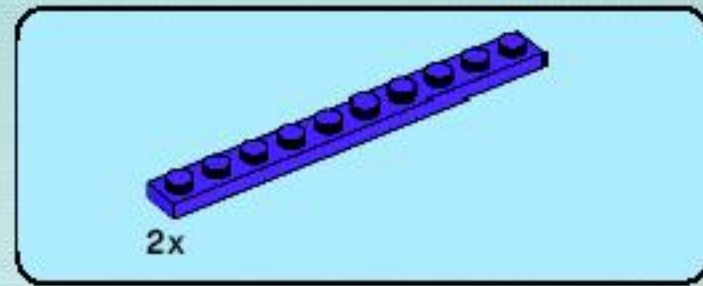
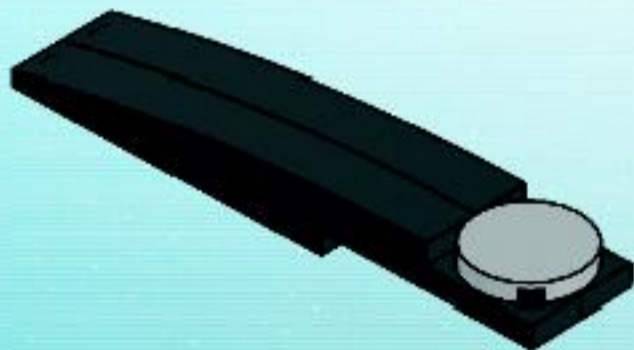

3

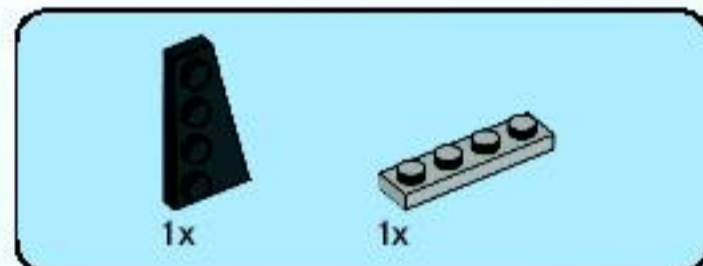
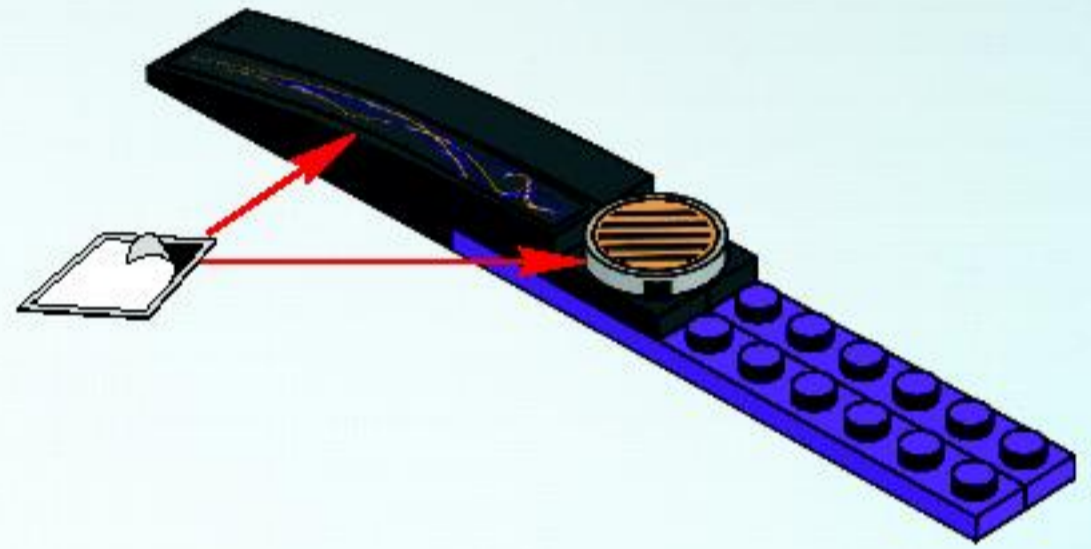

4

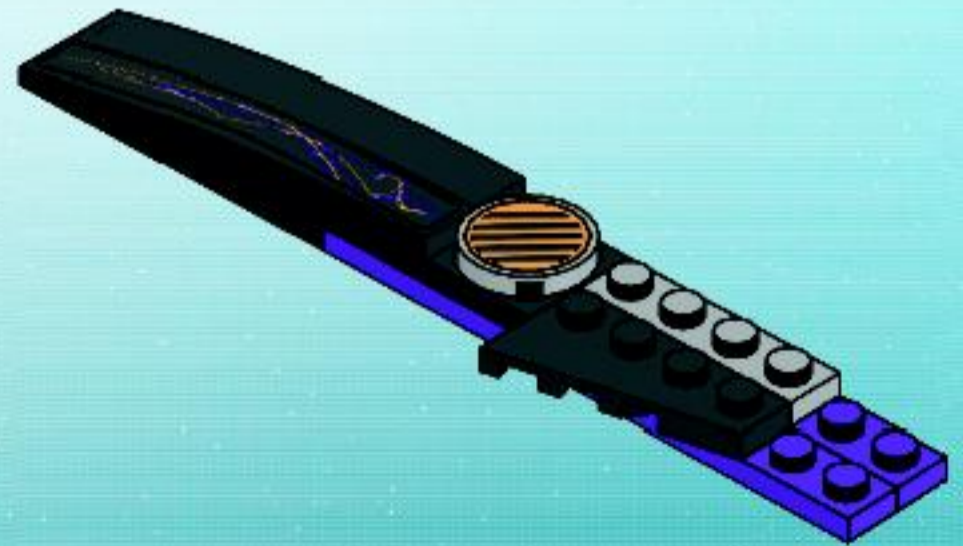

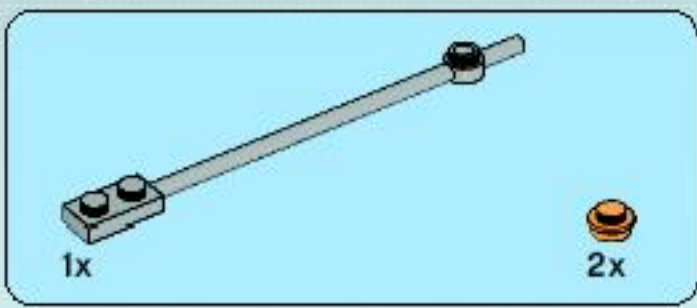

5

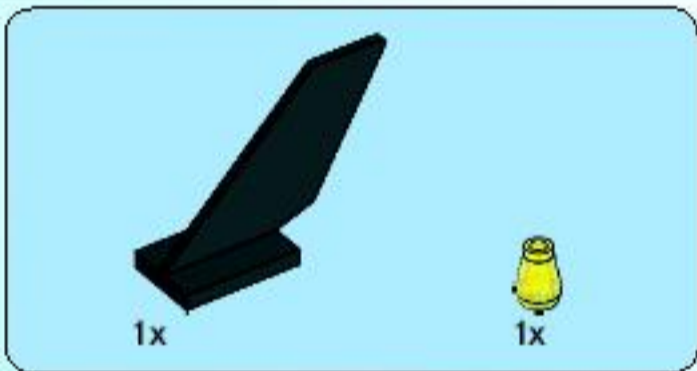
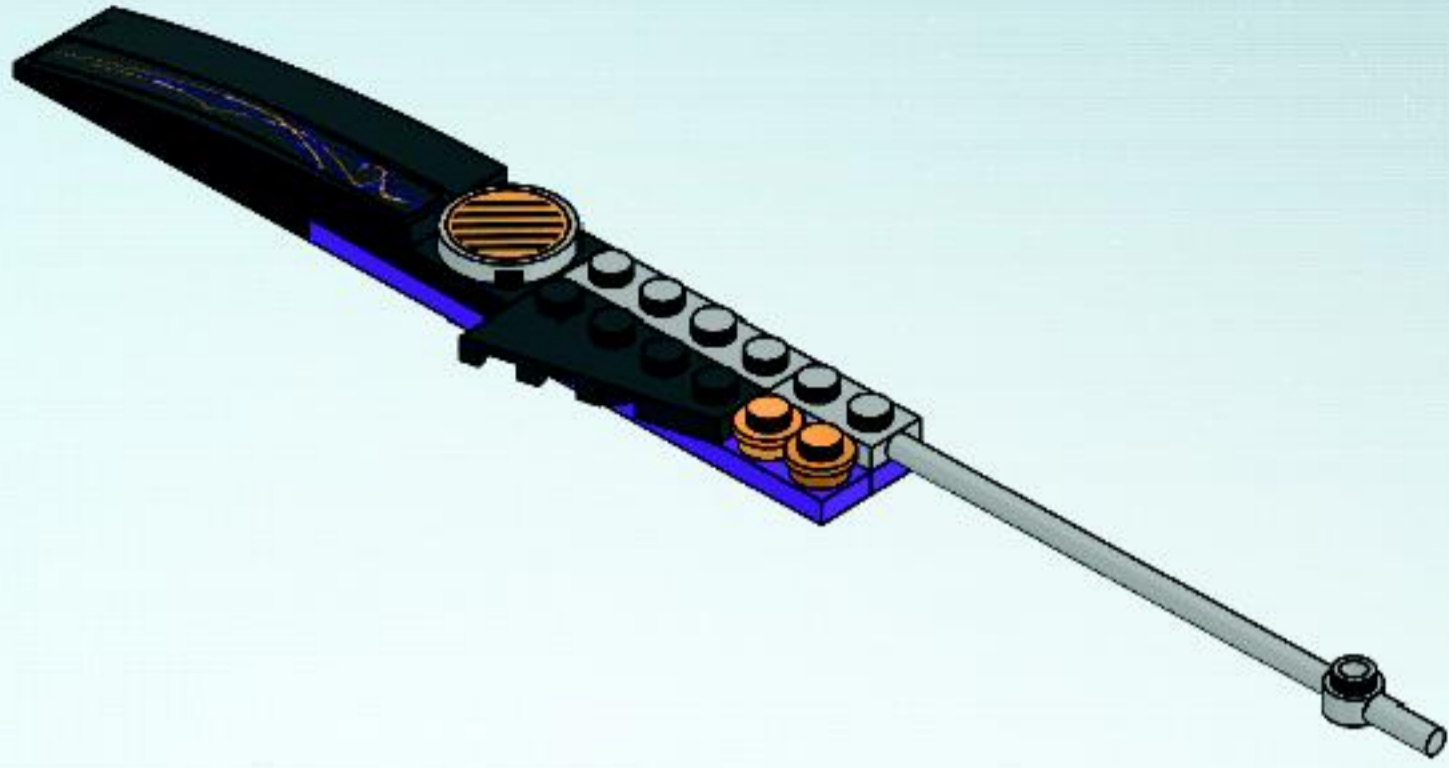

6

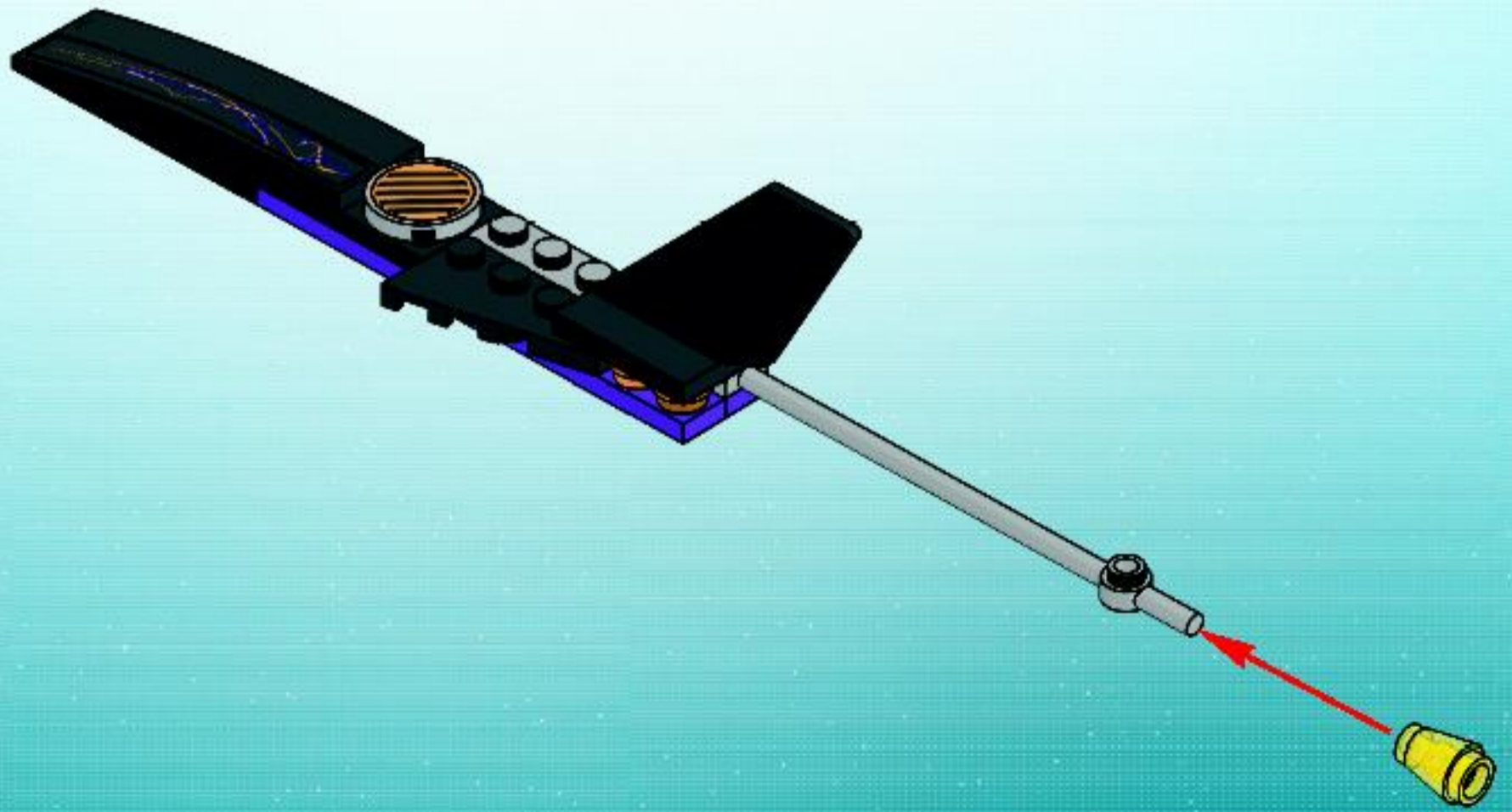



7

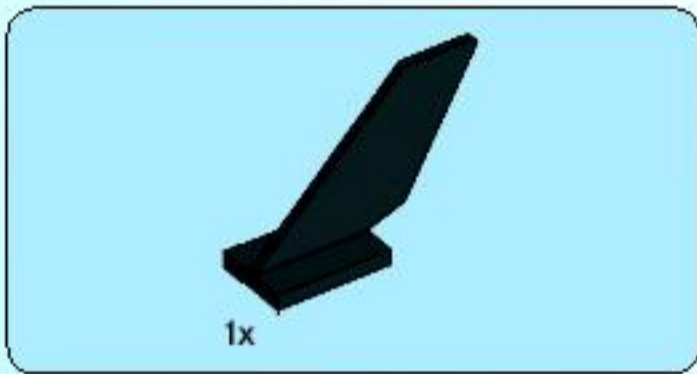
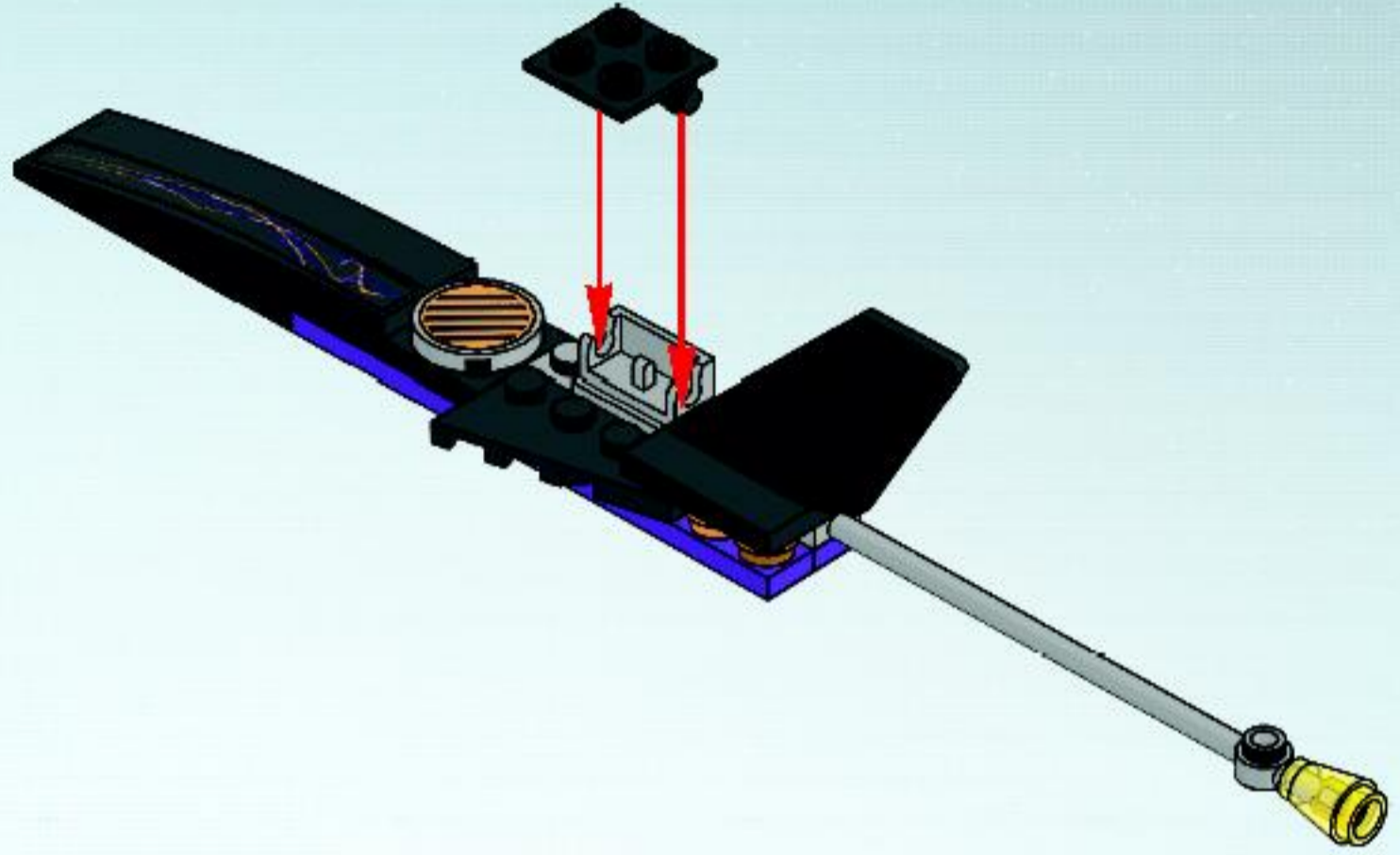

8

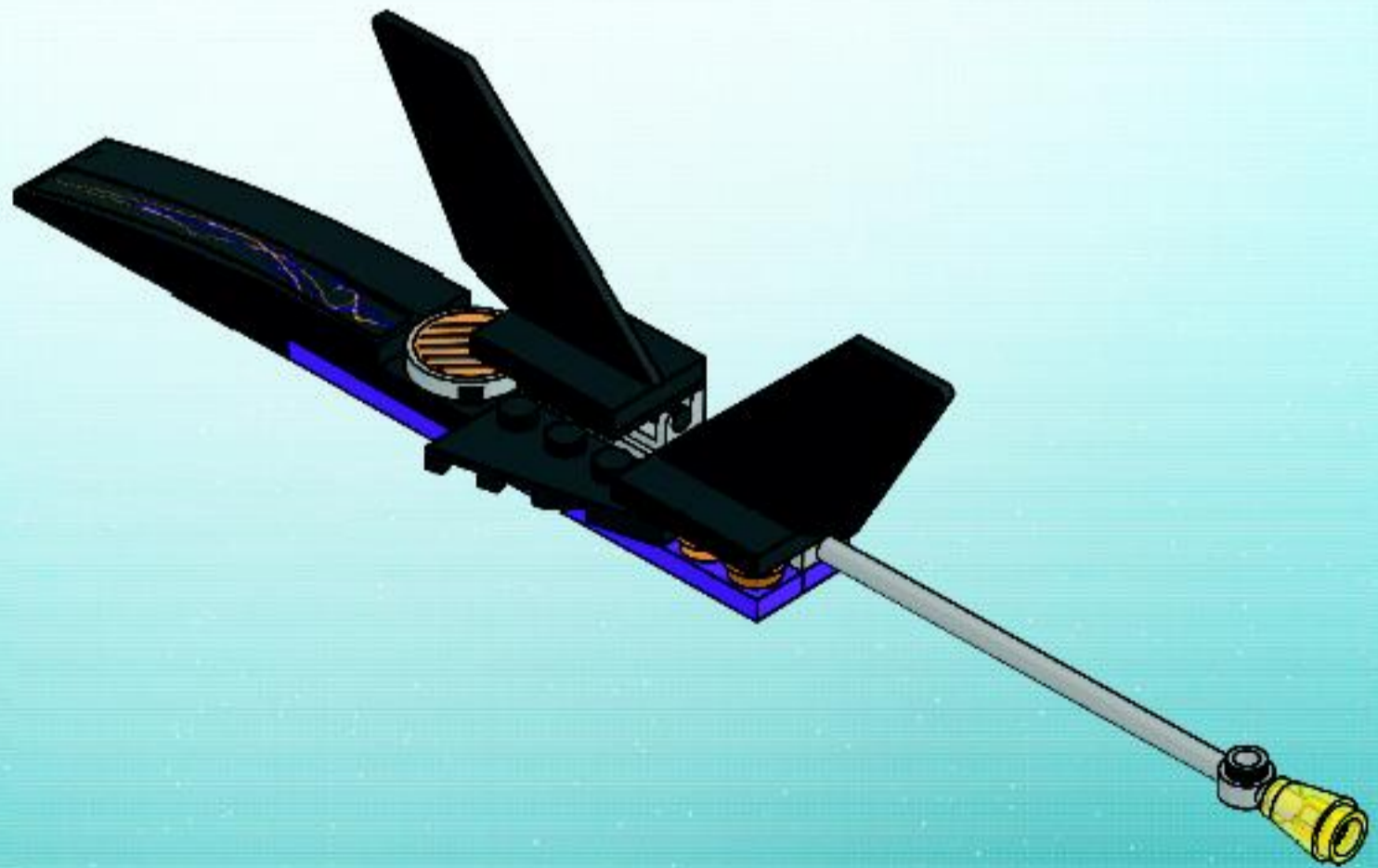

9

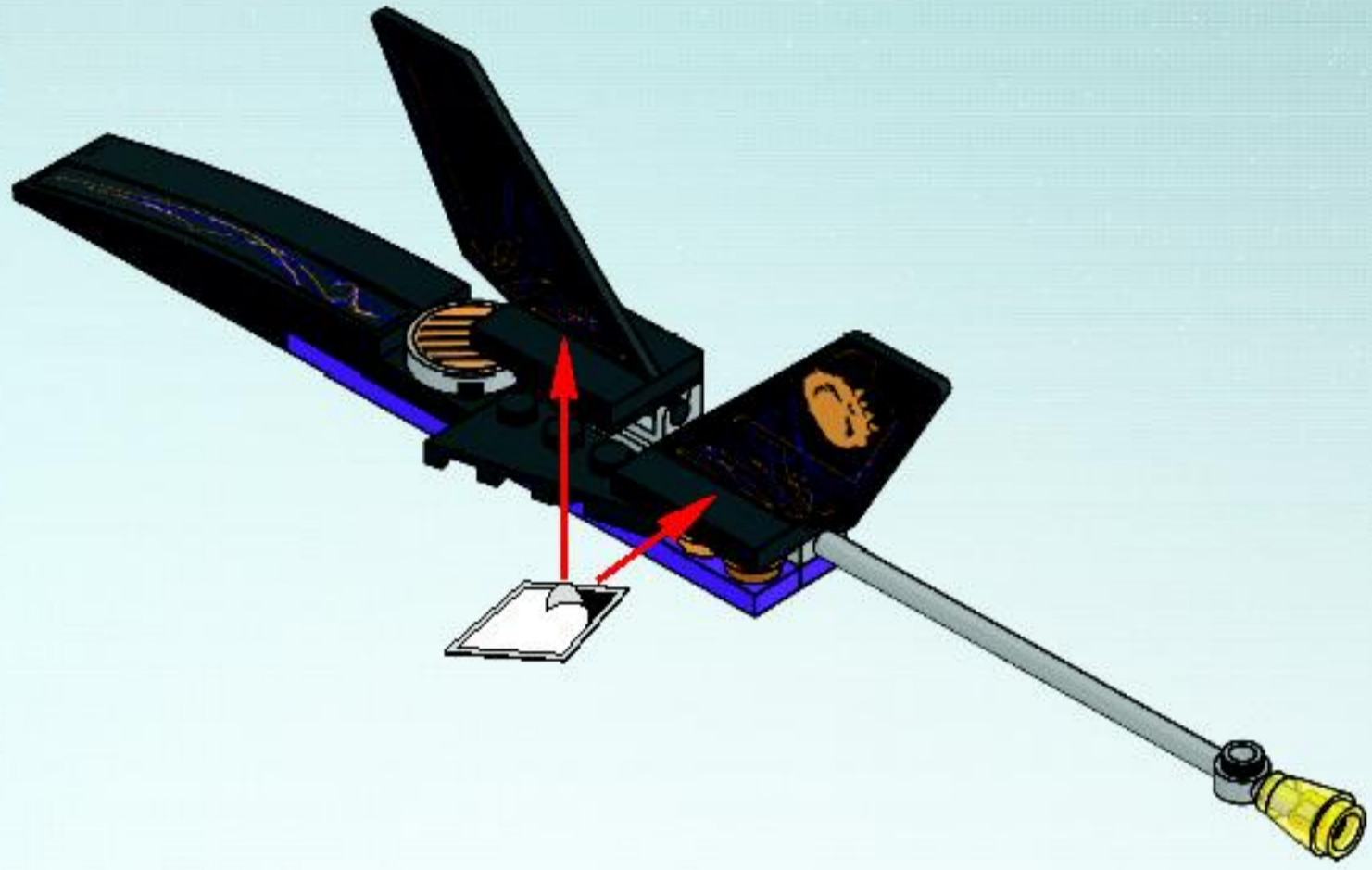

37

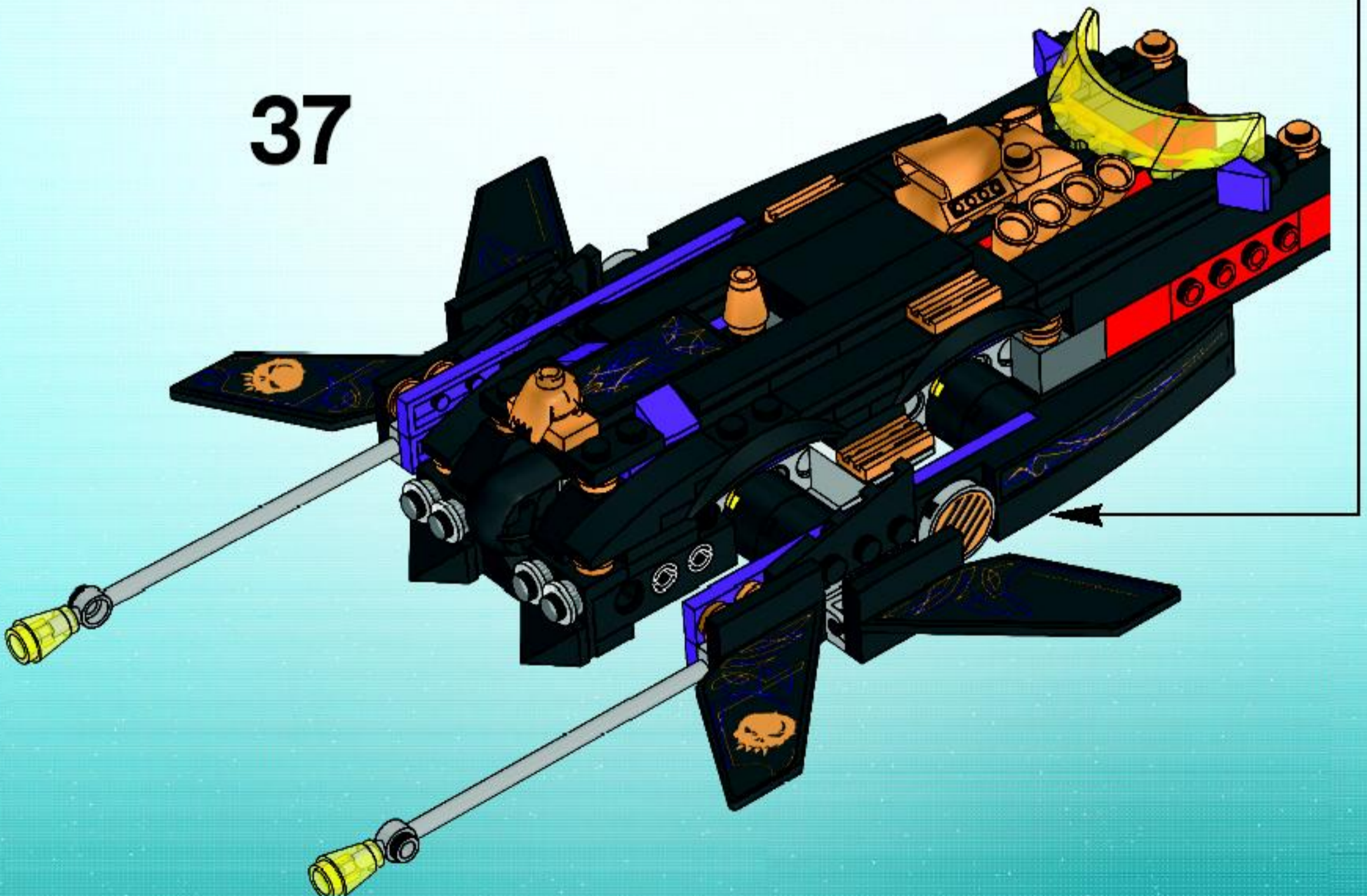



2x

3

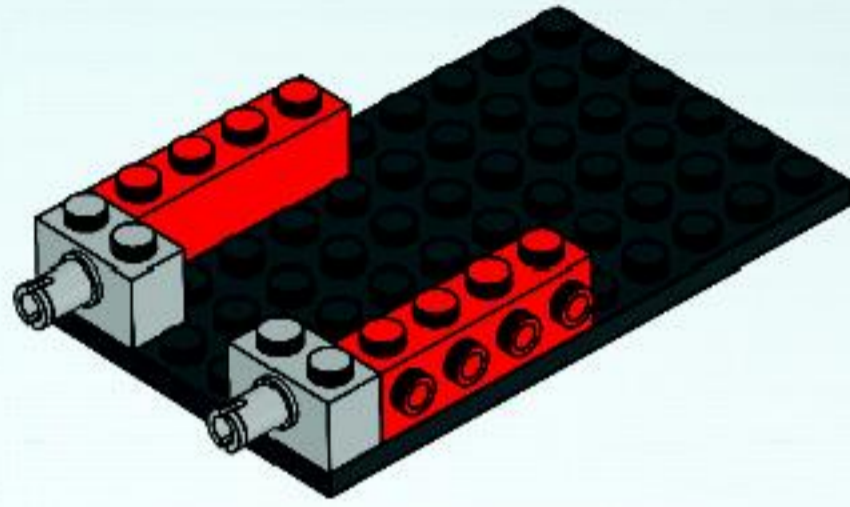

1x

4

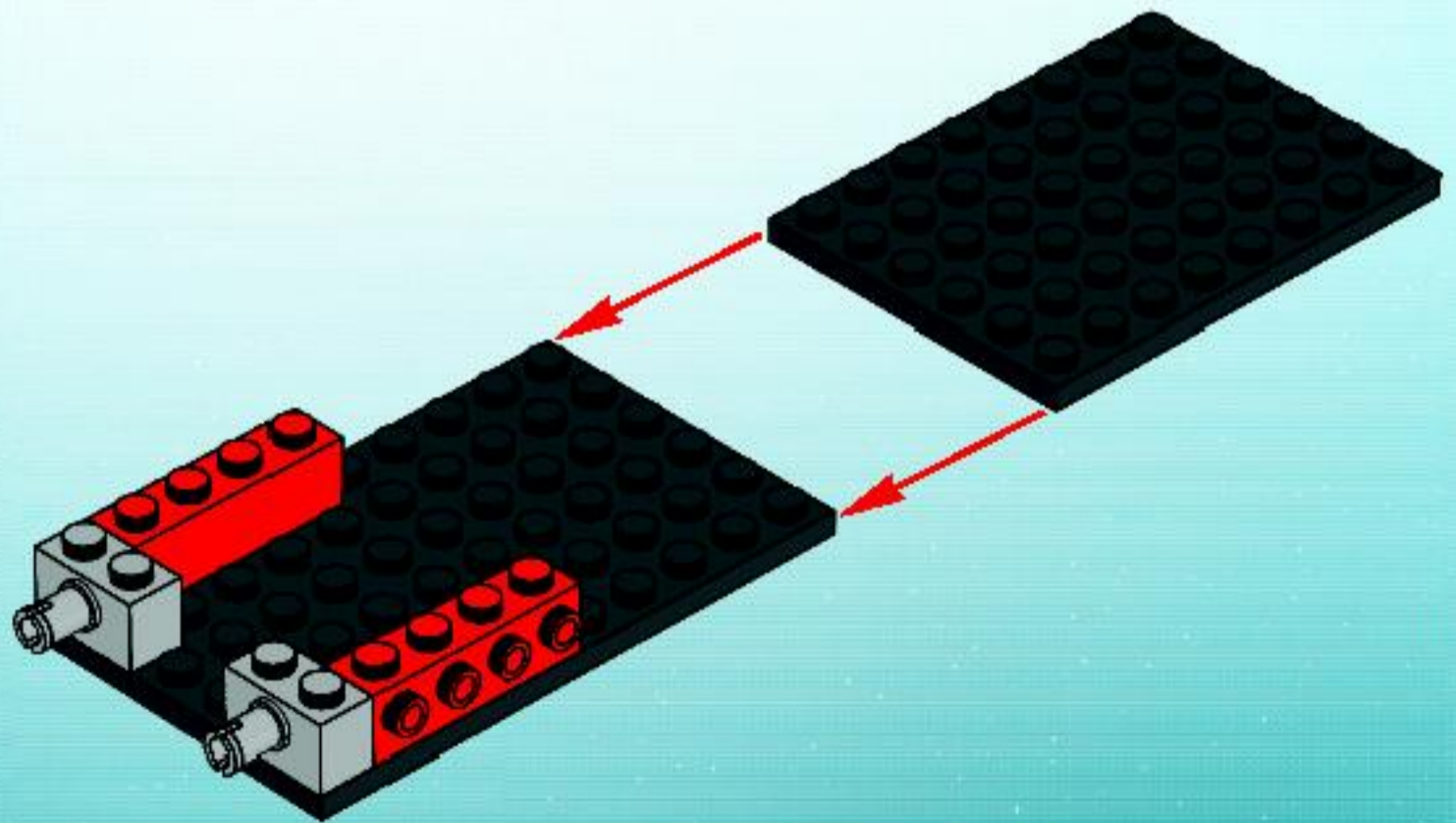

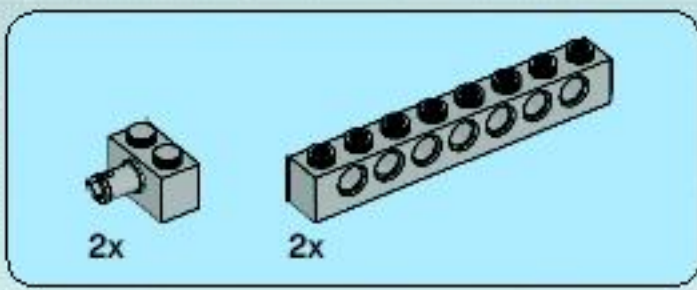

5

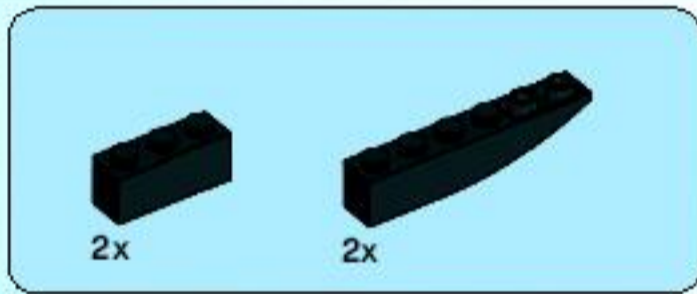
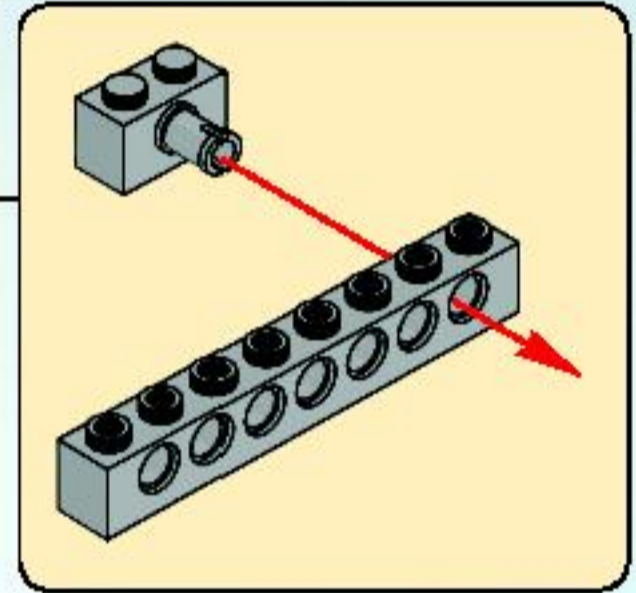
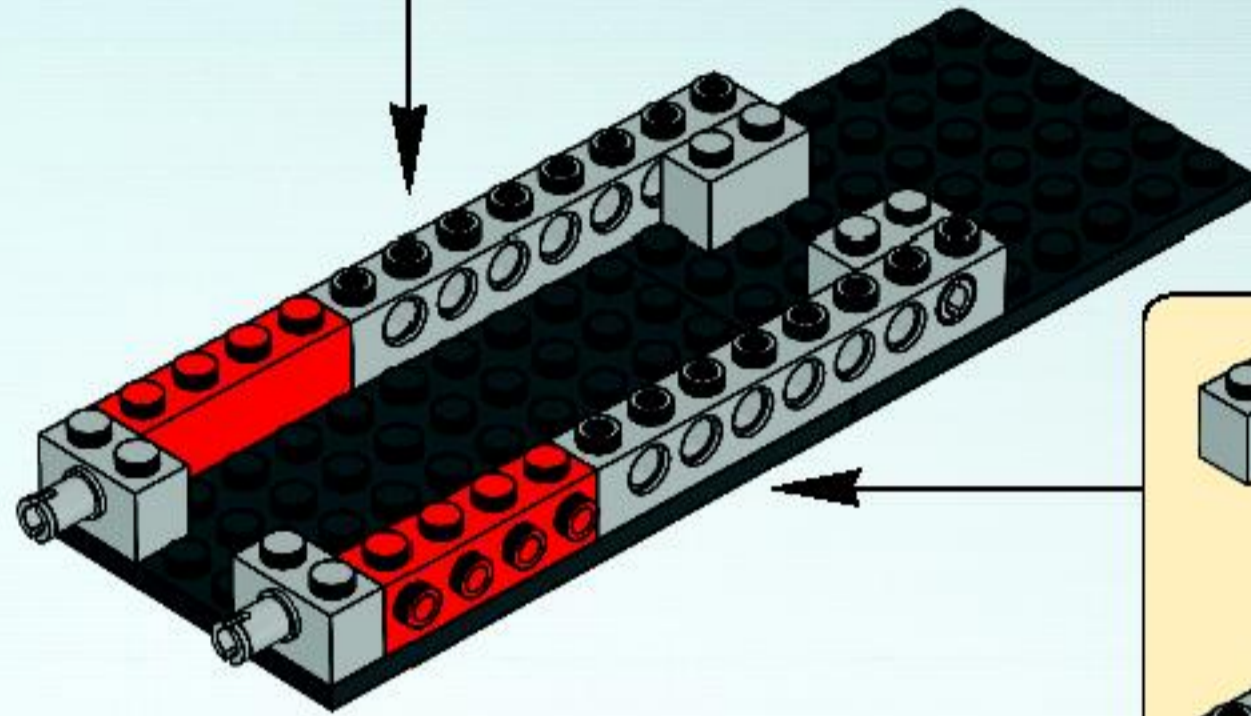
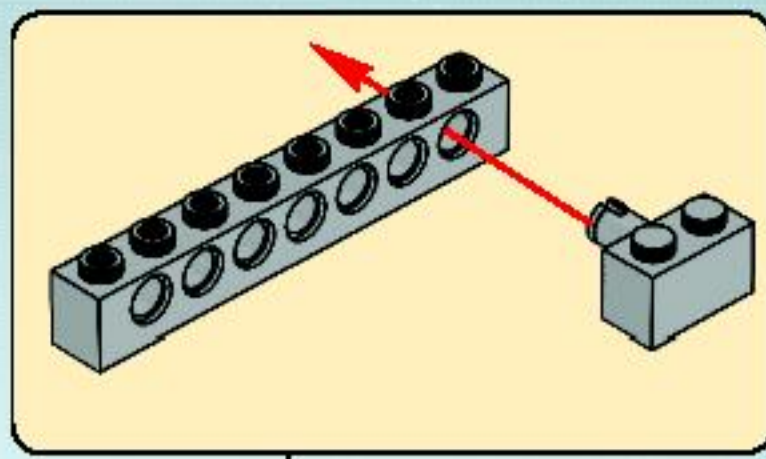

6

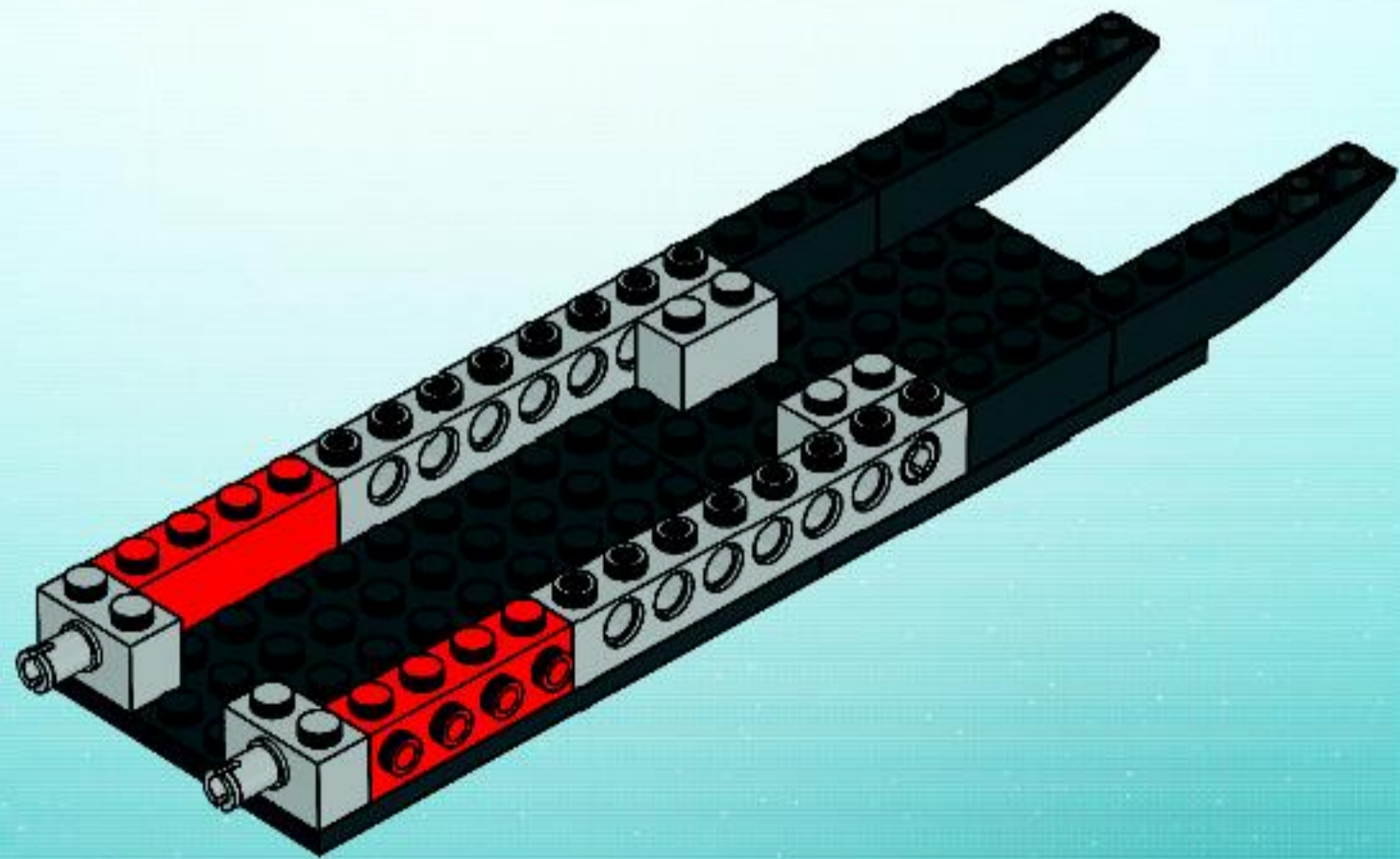

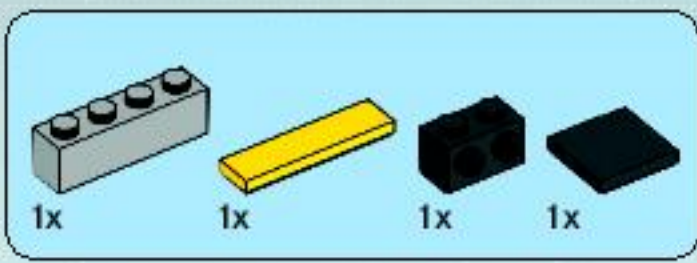

7

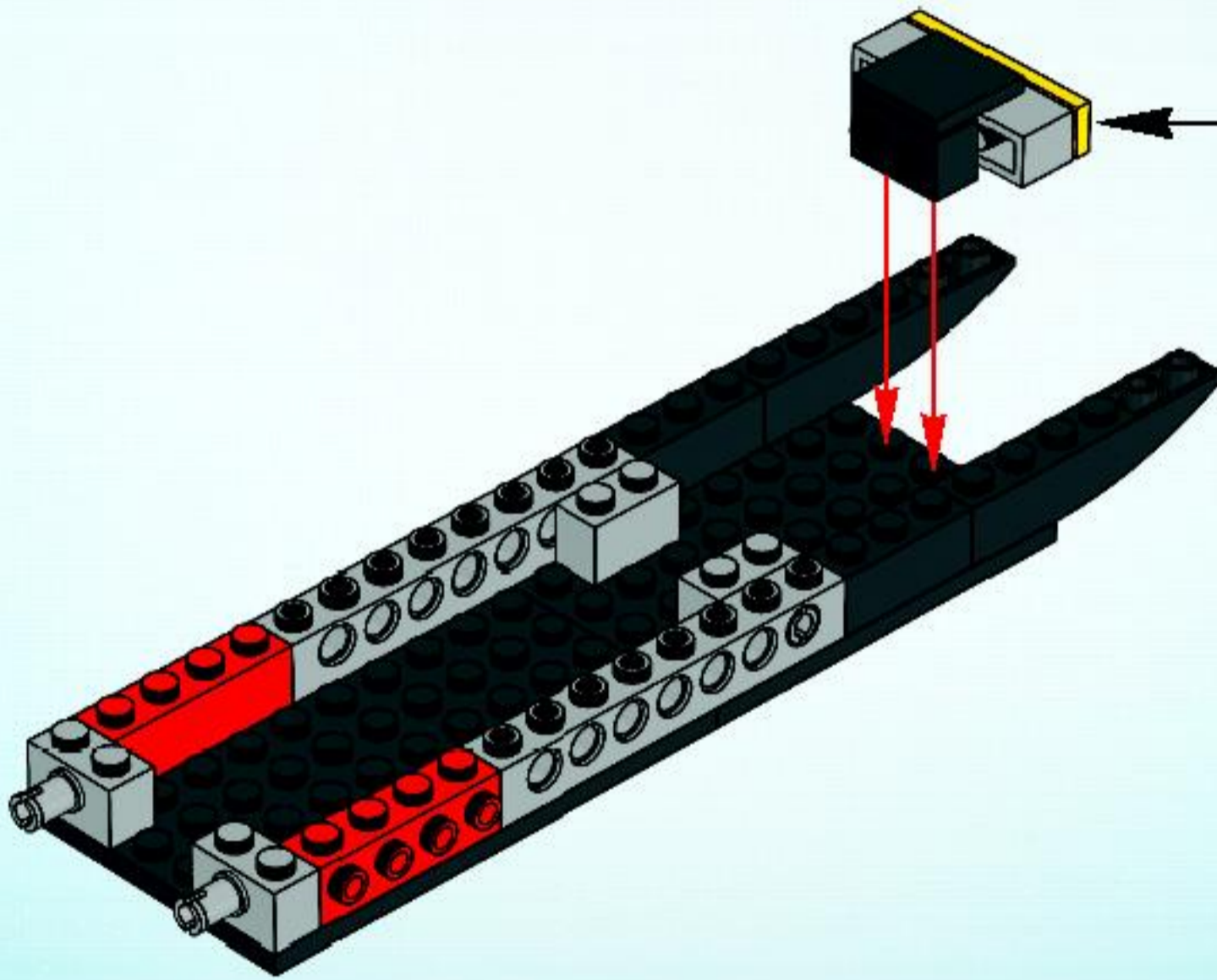
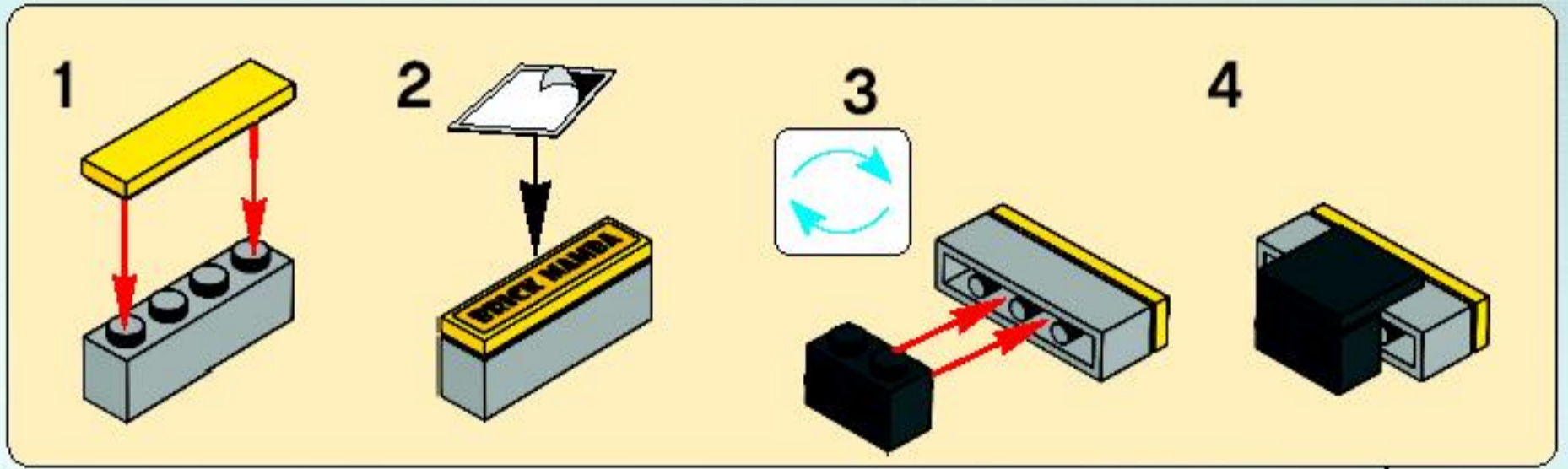

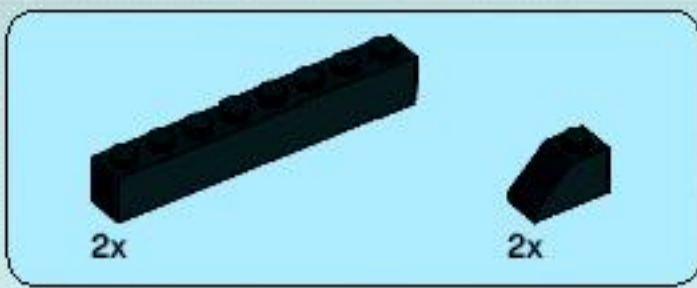

8

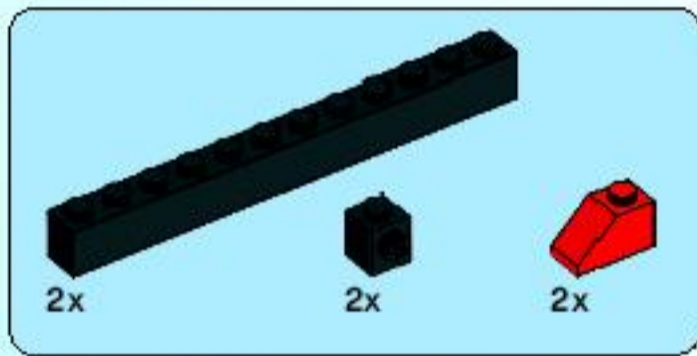
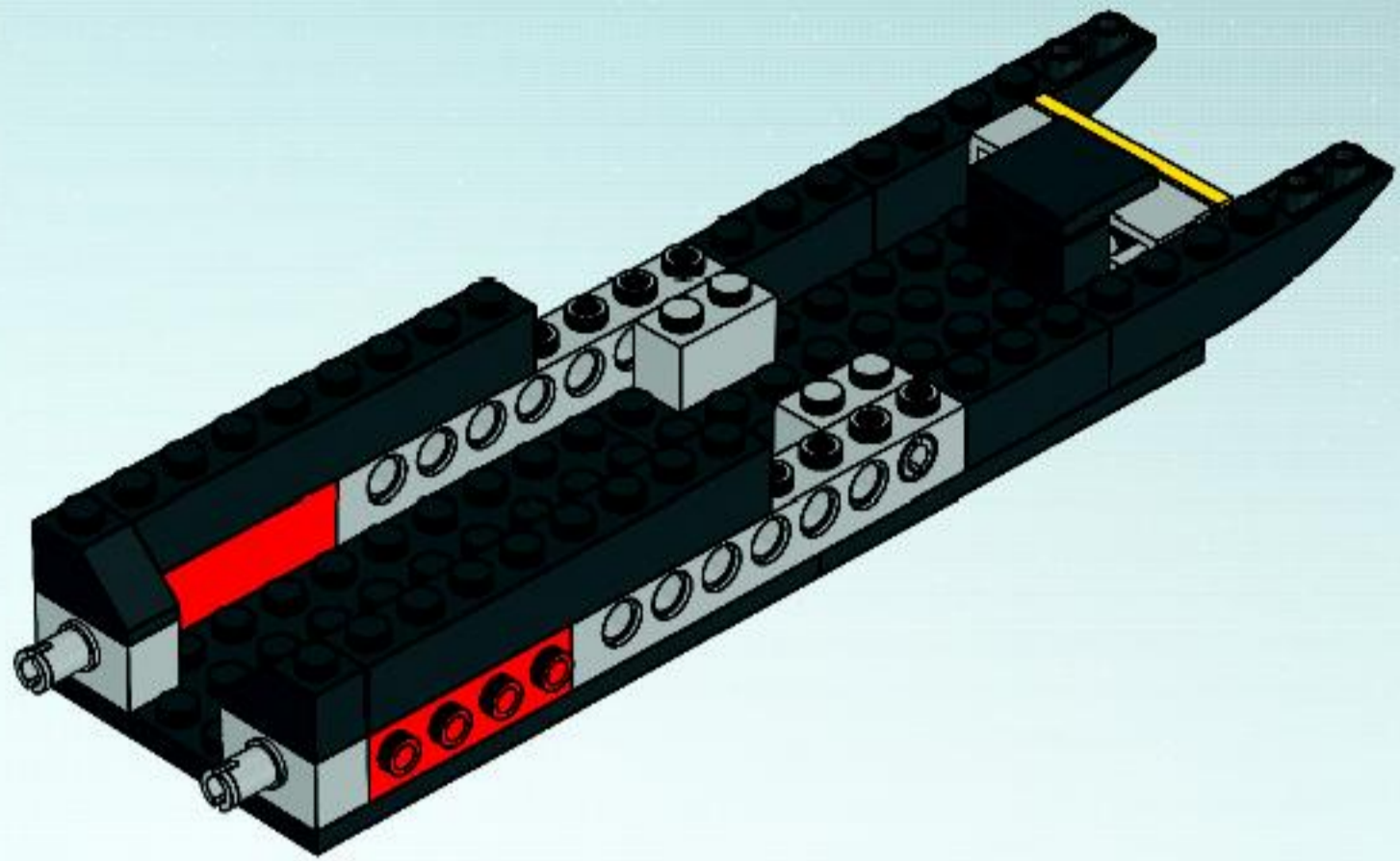

9

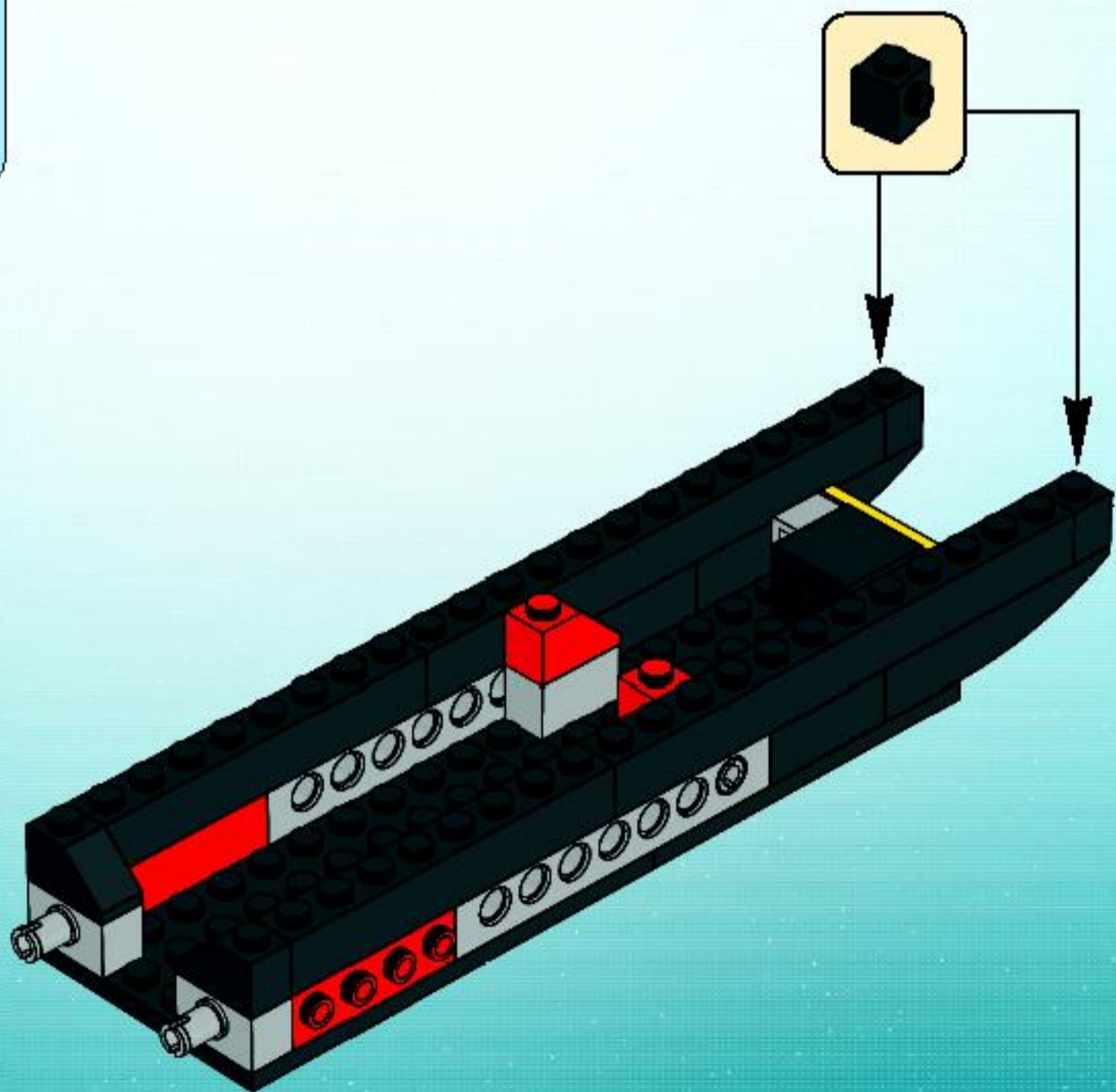

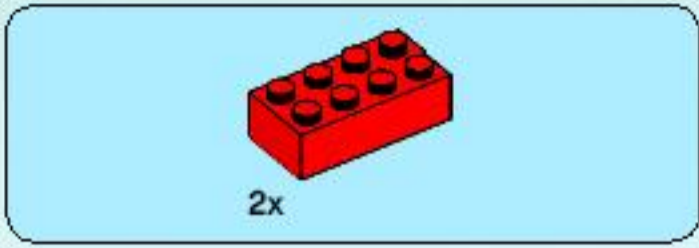

1

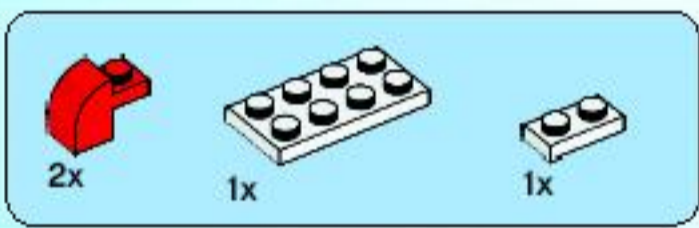
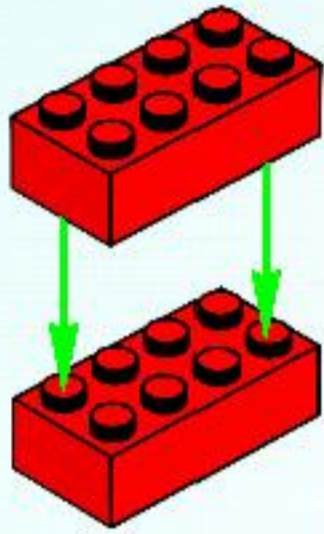

2

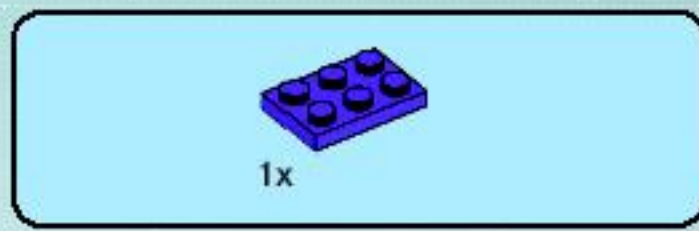

3



4

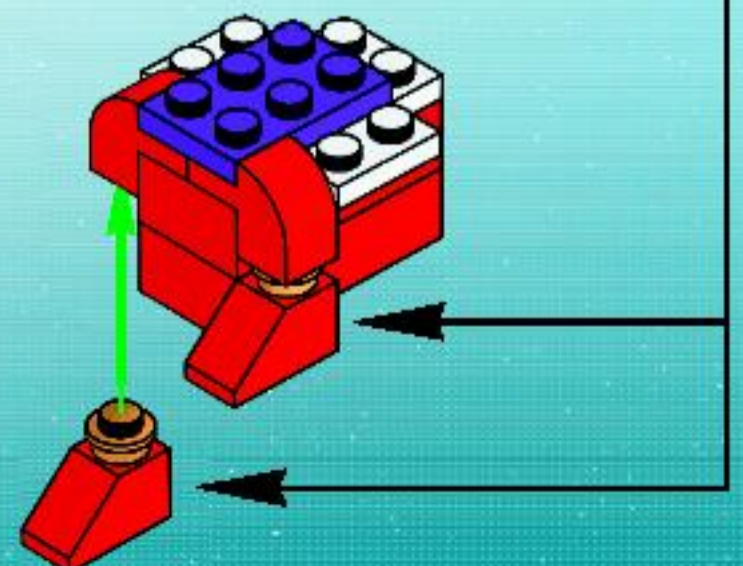
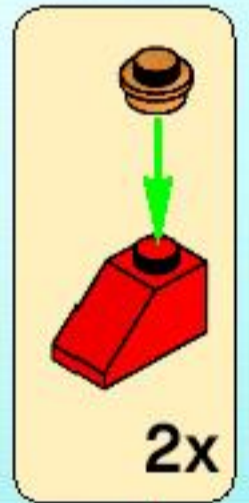

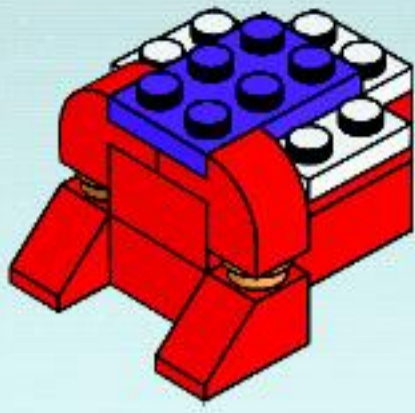

10

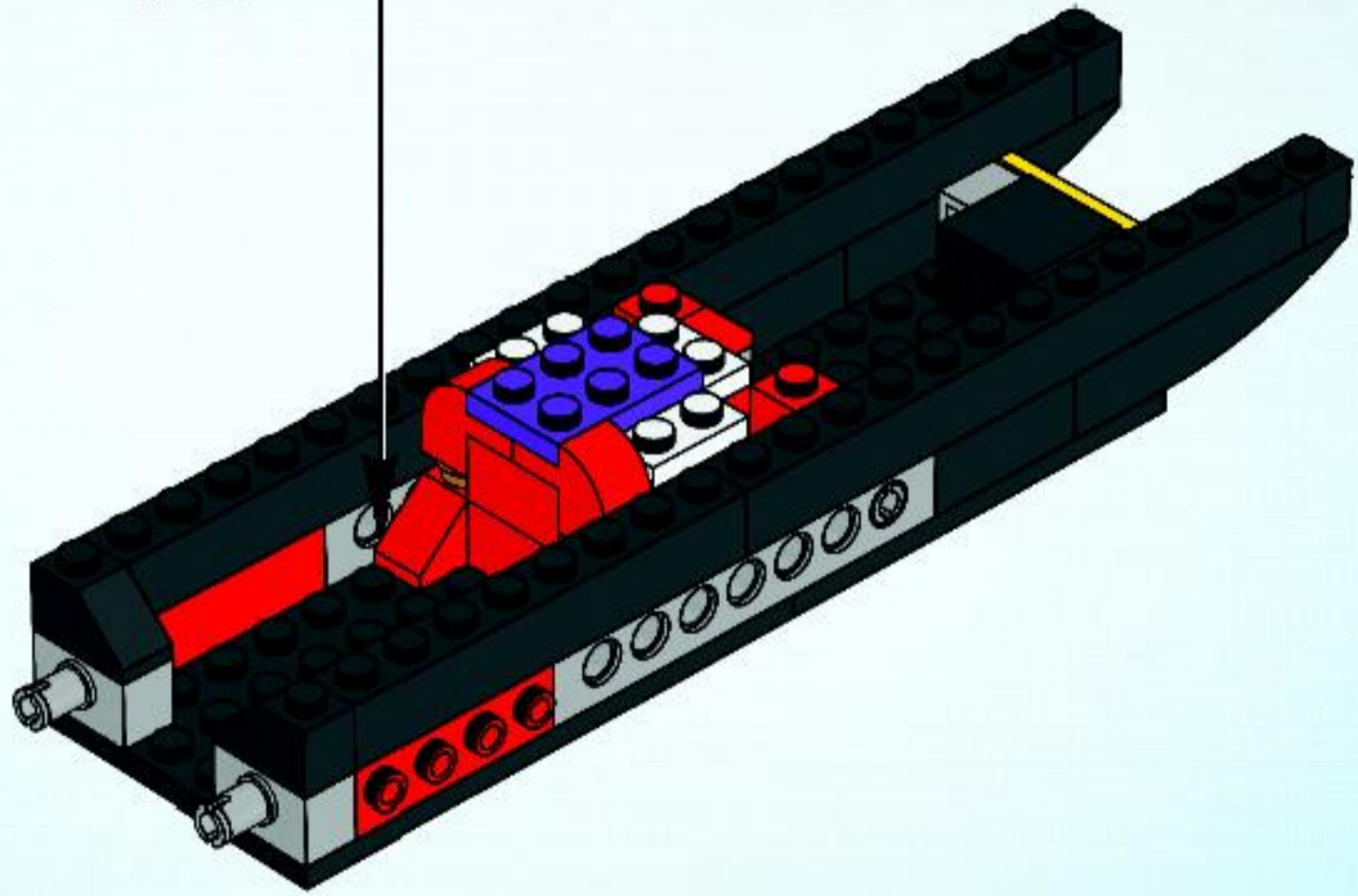



11

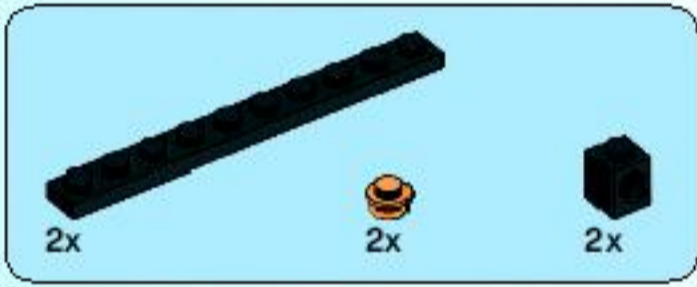
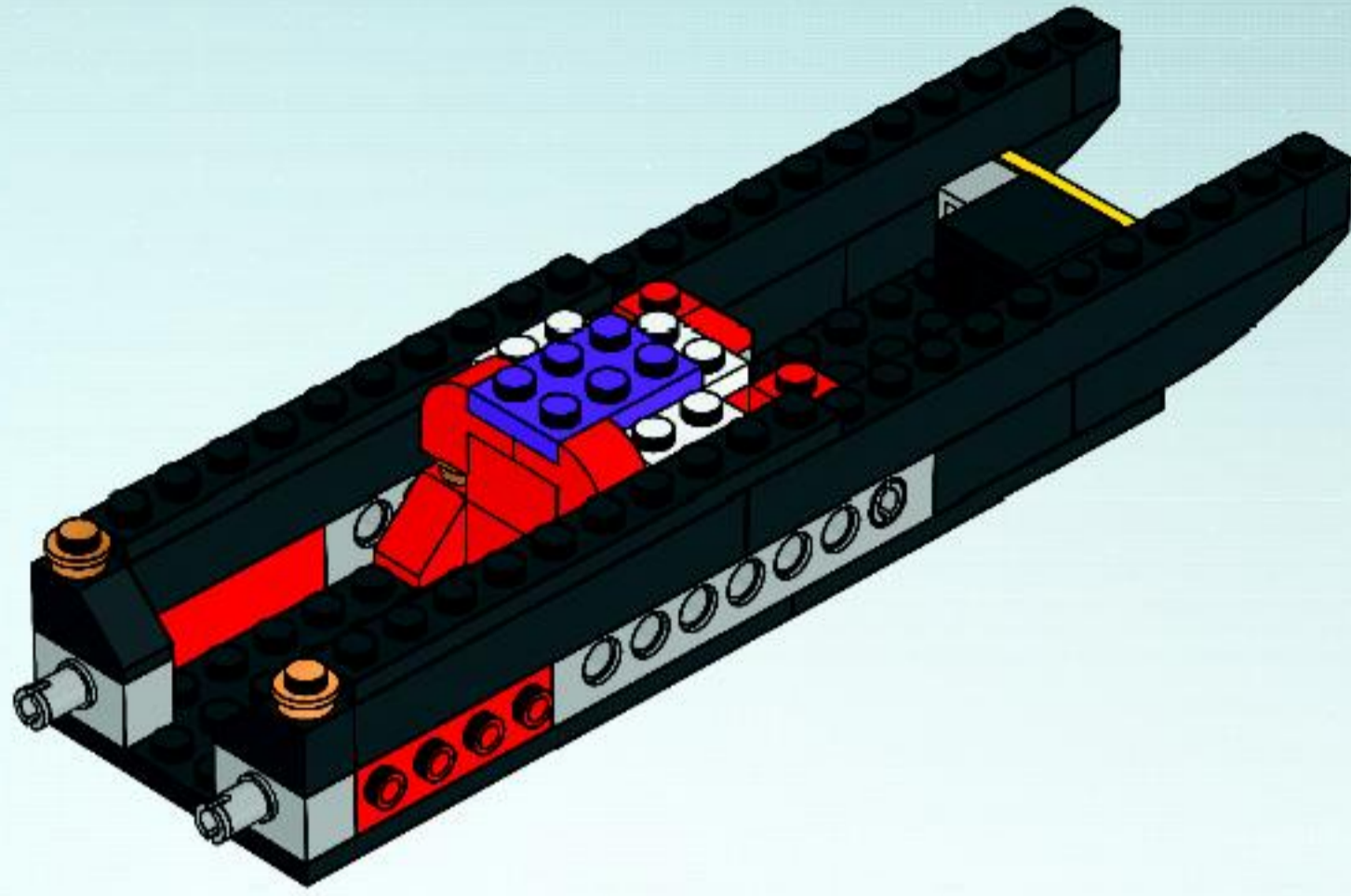

12

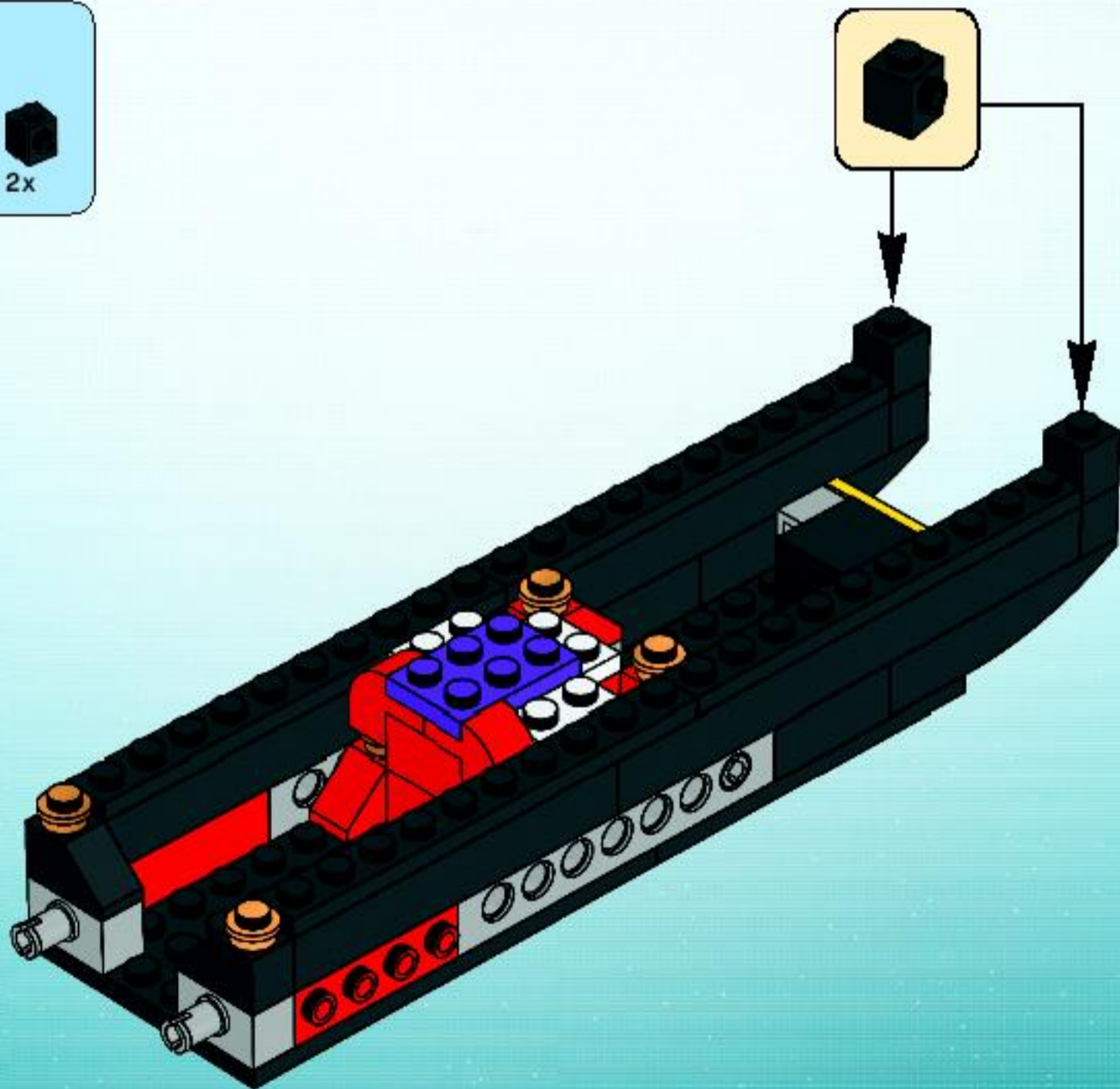



13

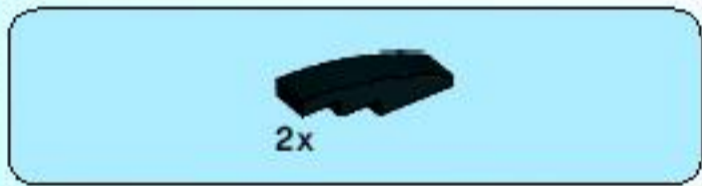
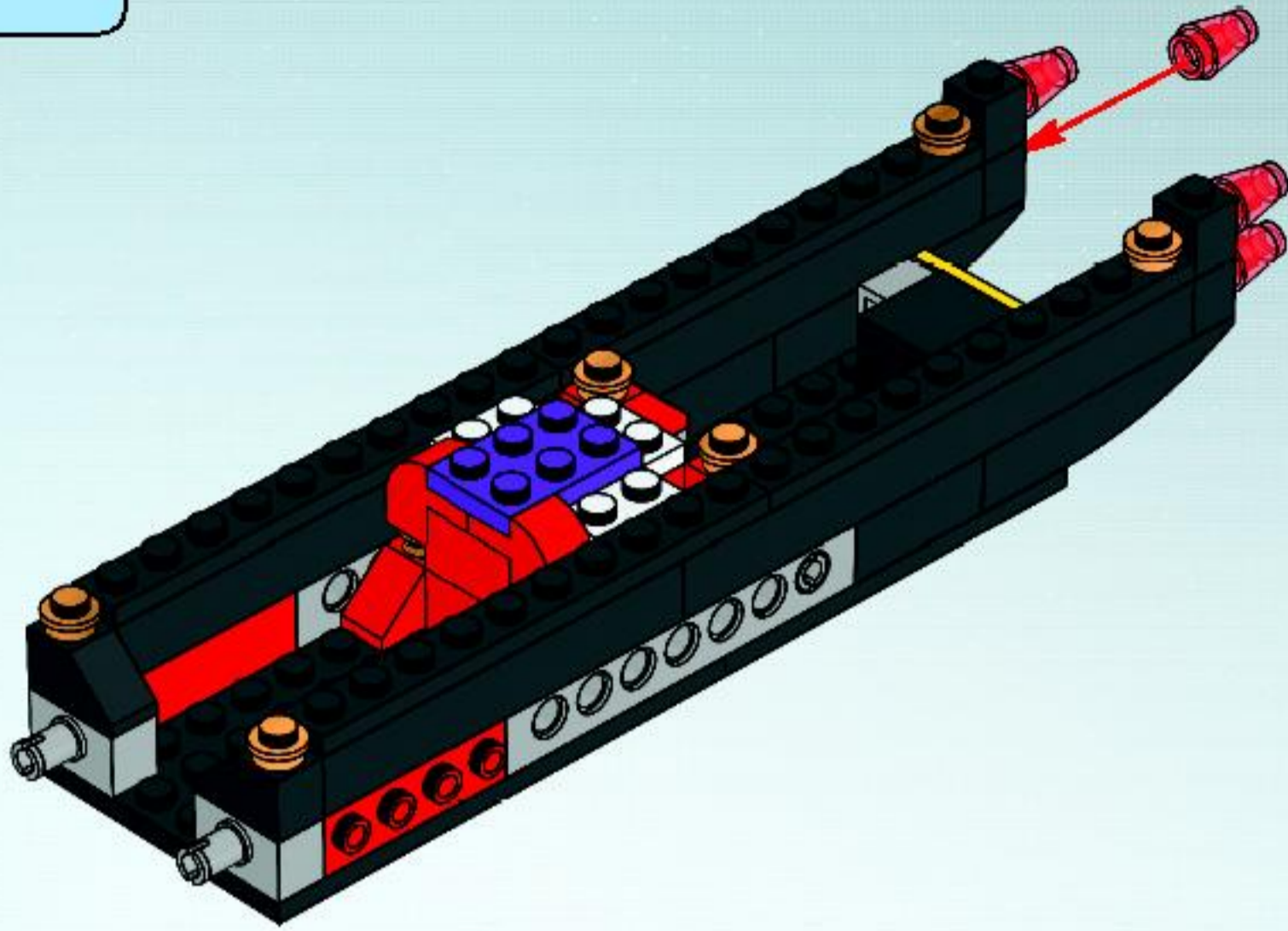

14

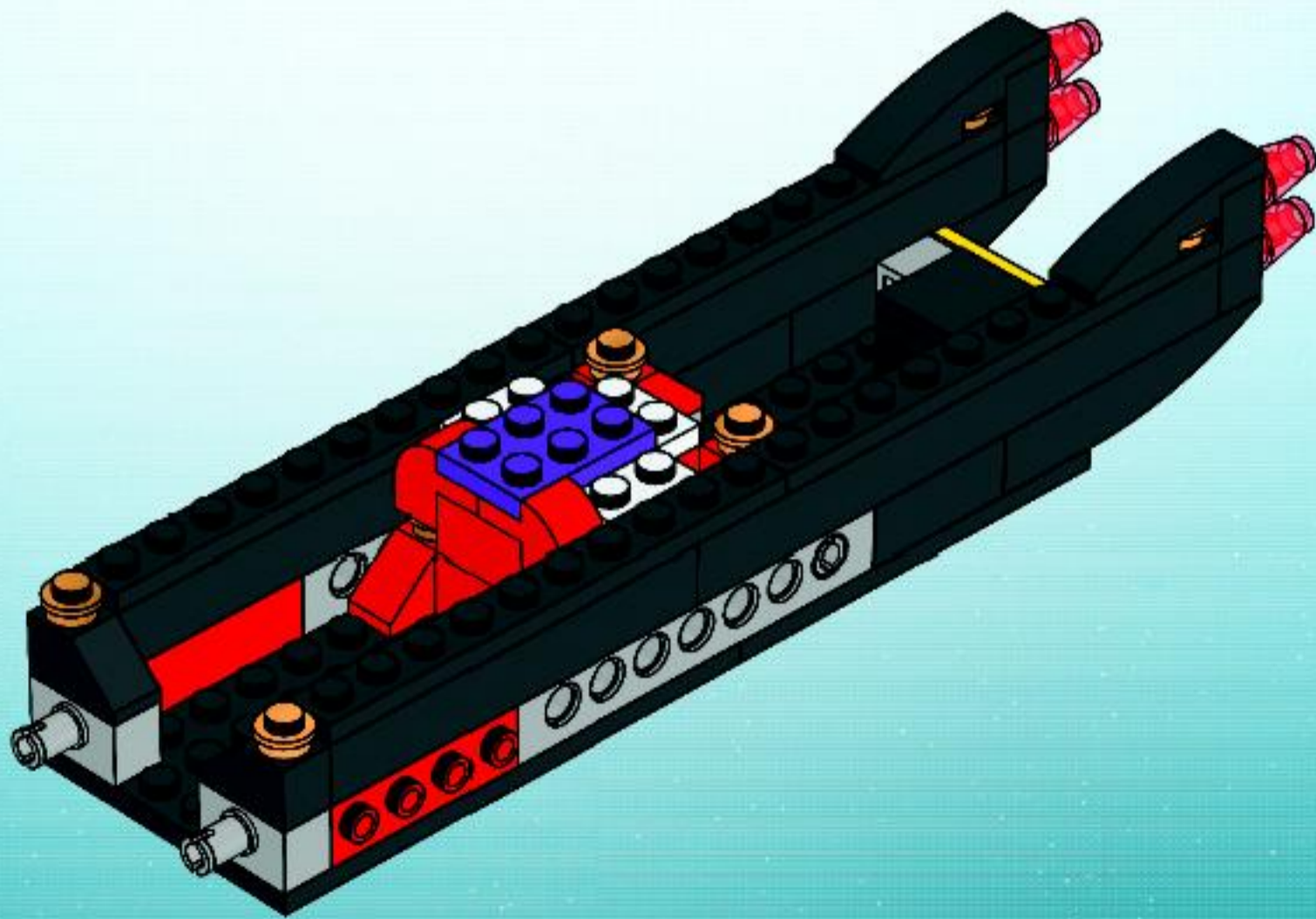

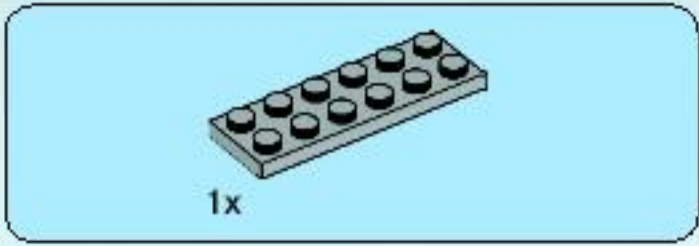

1x

1

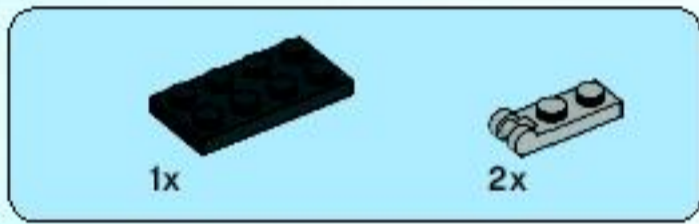
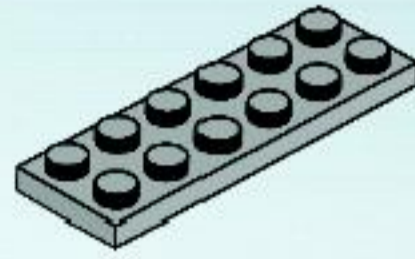

1x

2x

2

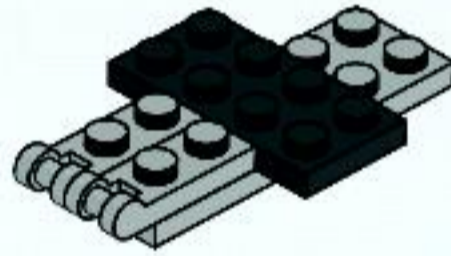

1x

3

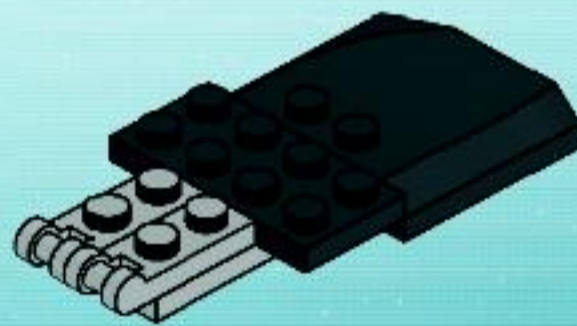



4

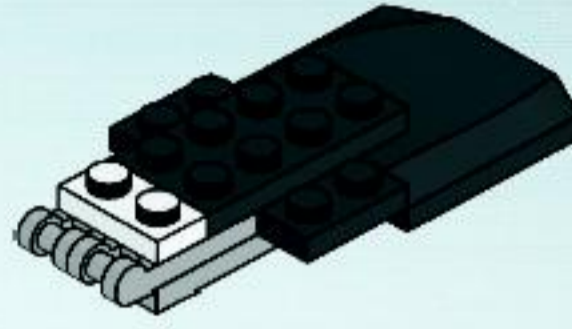

5

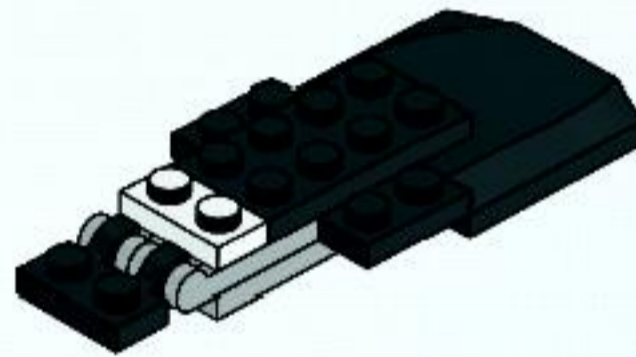

6

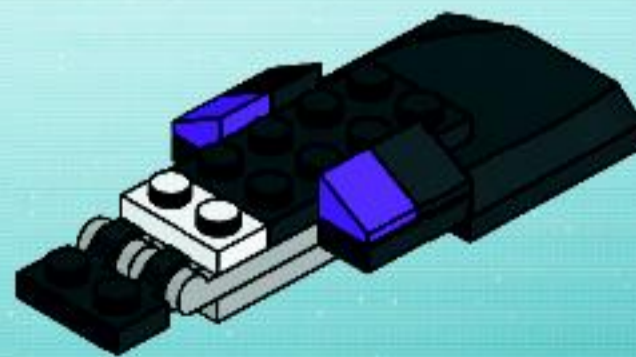

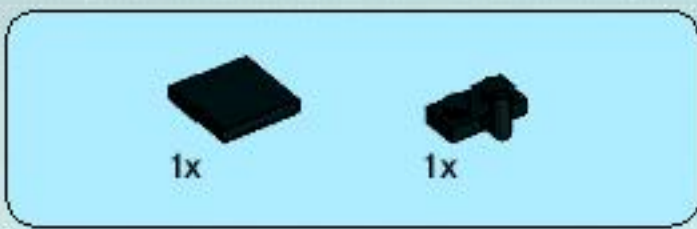

7

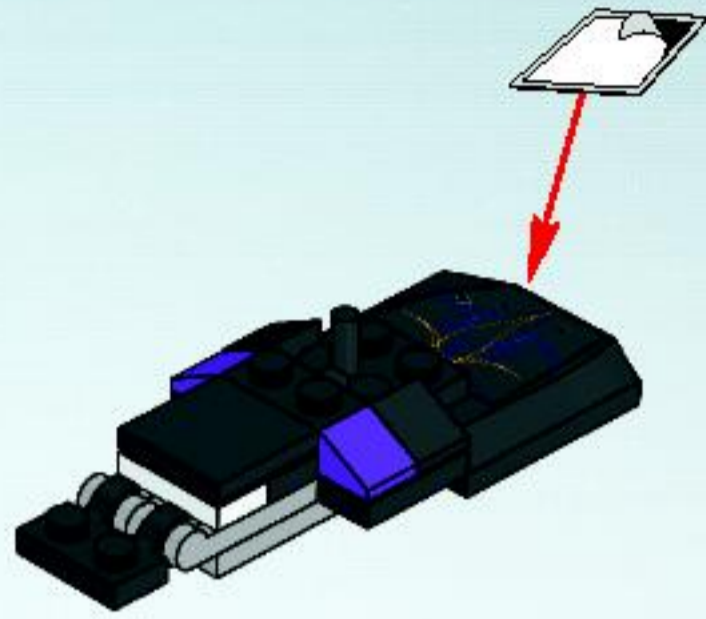

8

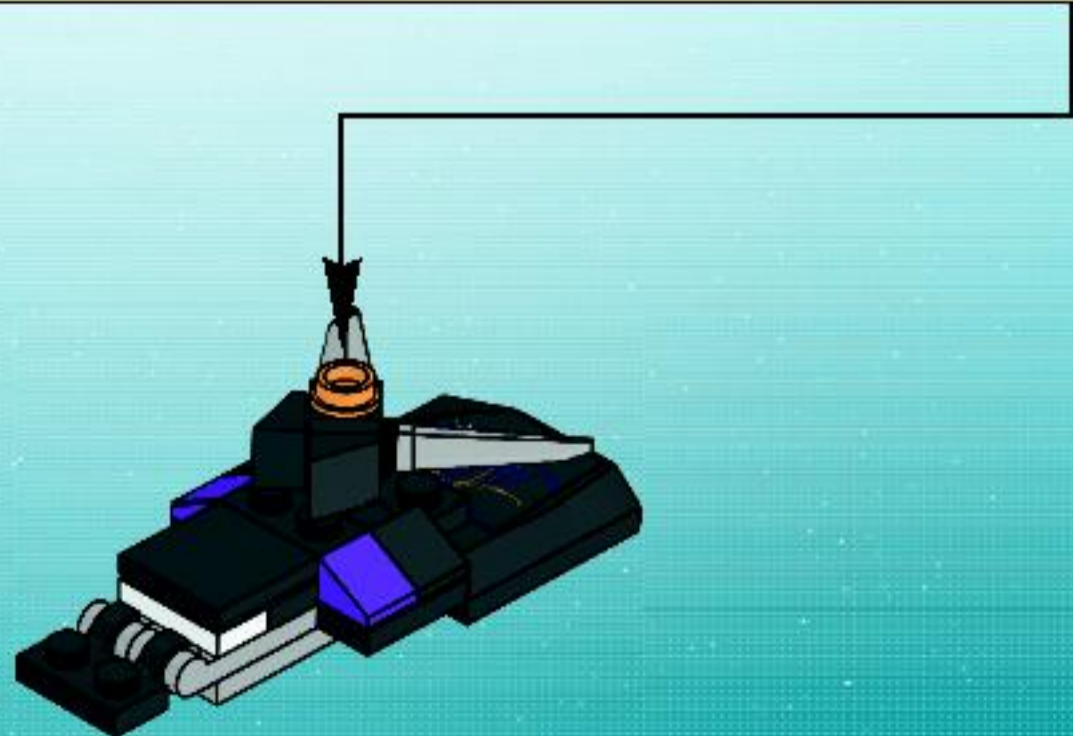
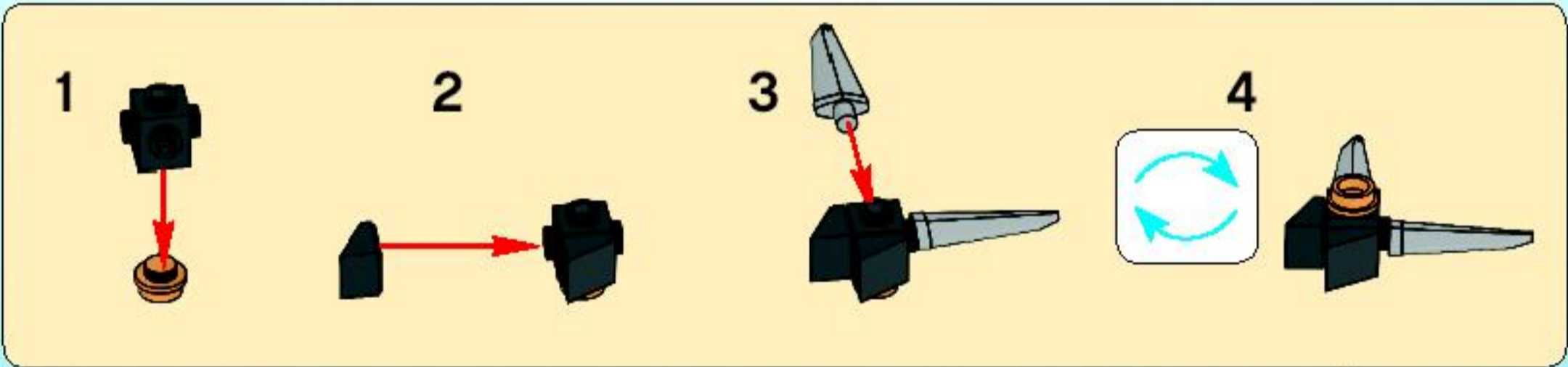

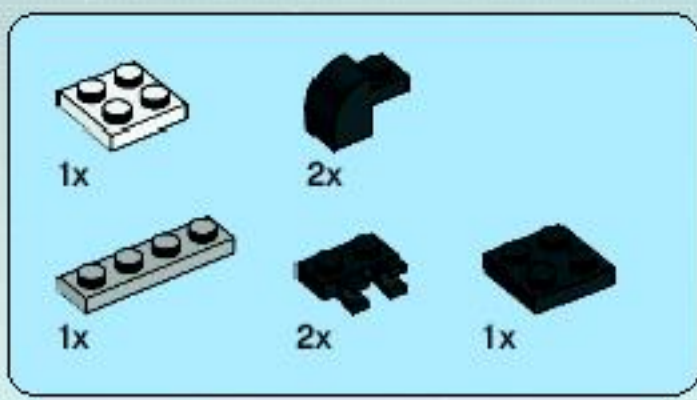

17

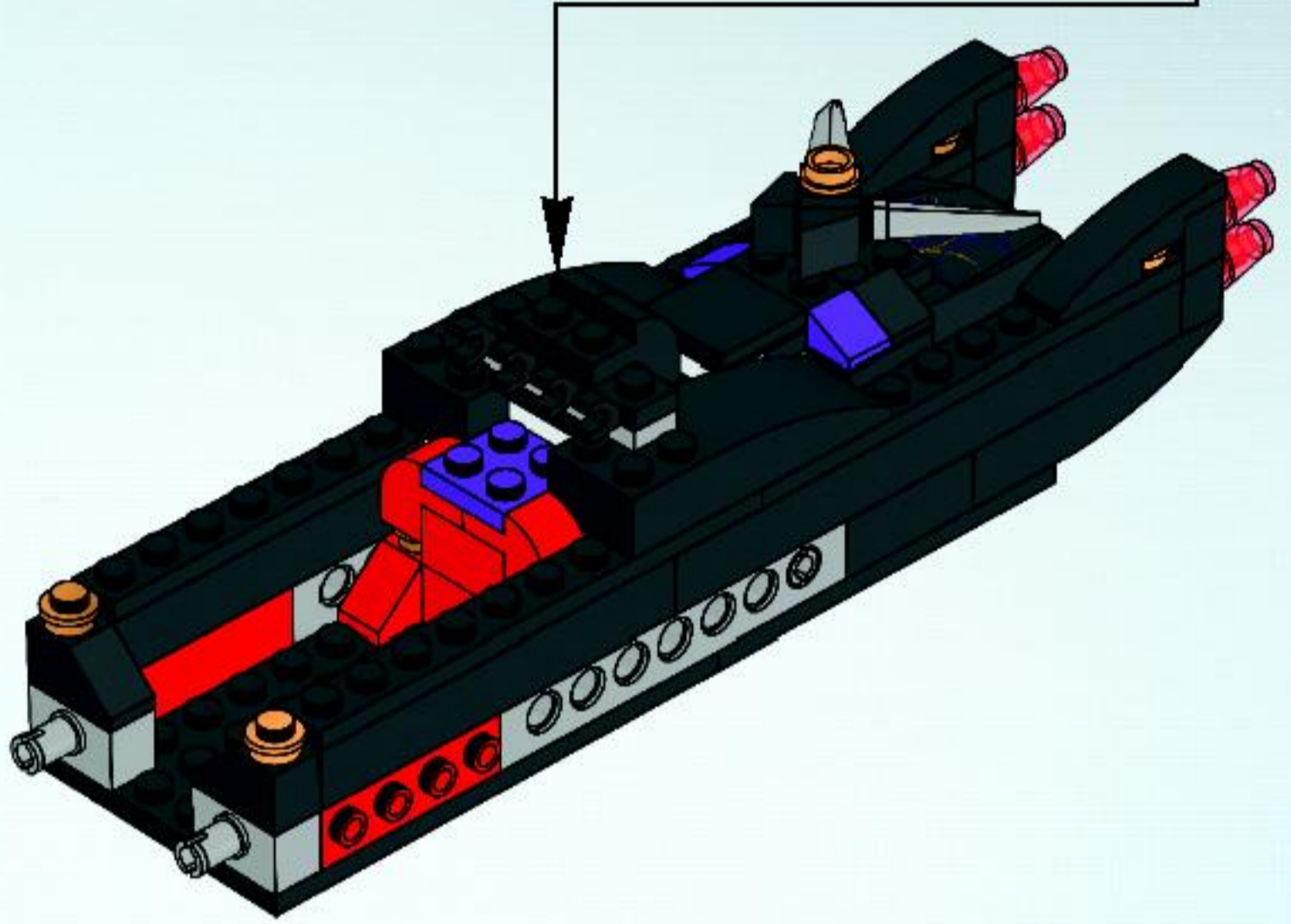
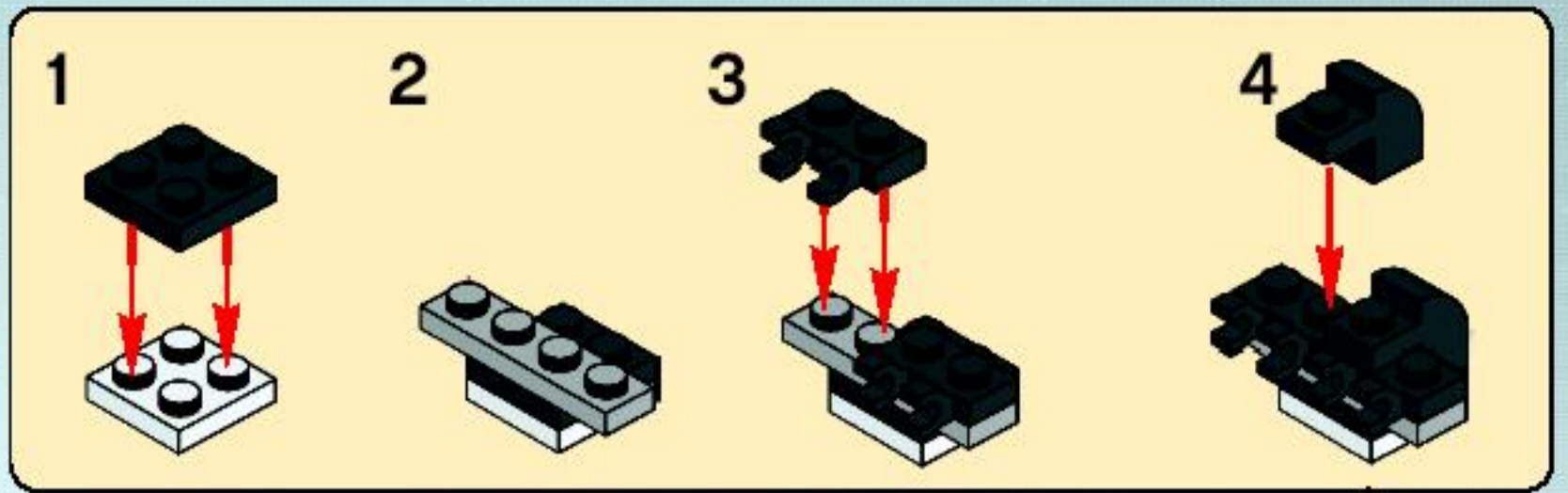

18

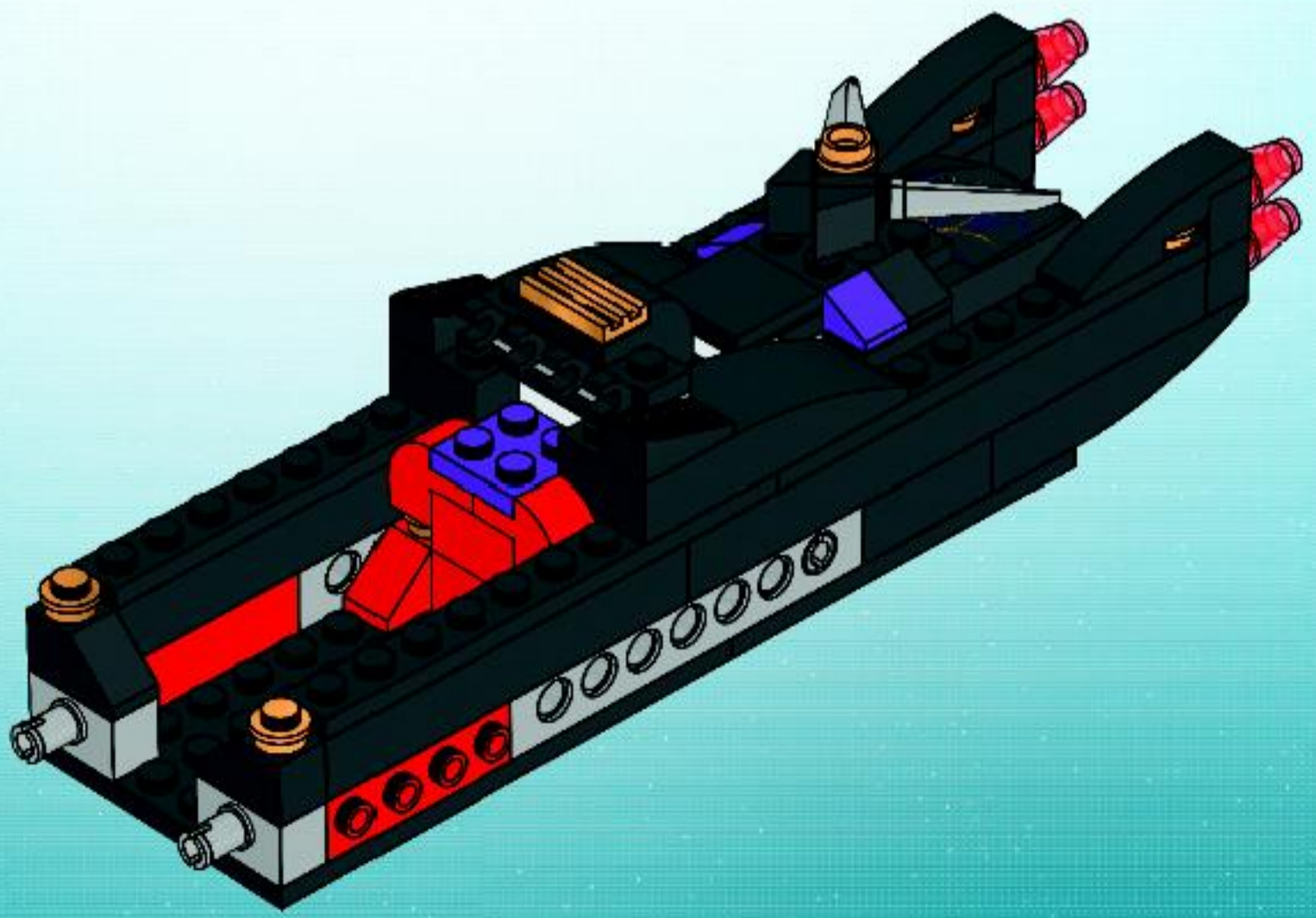

19

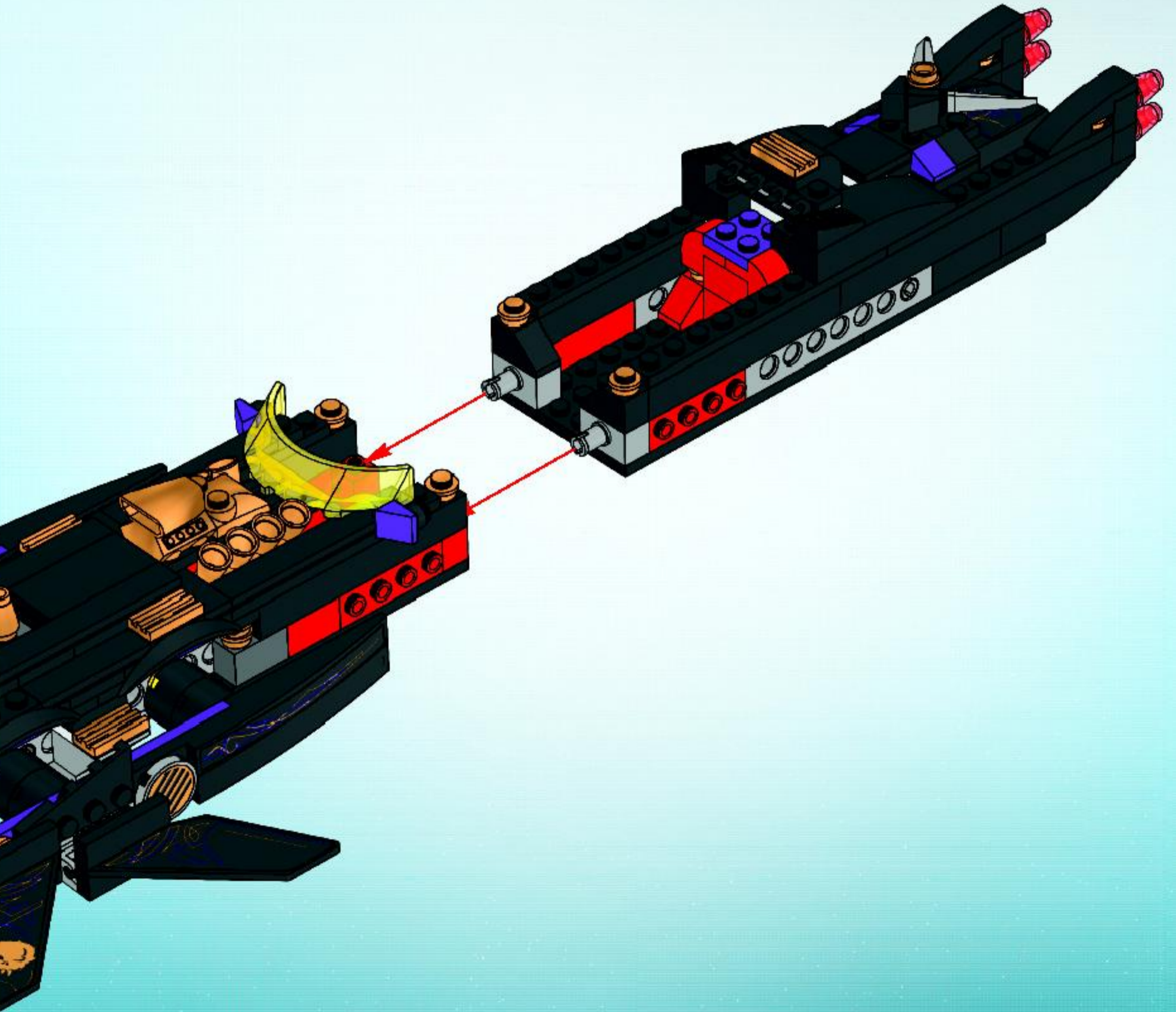

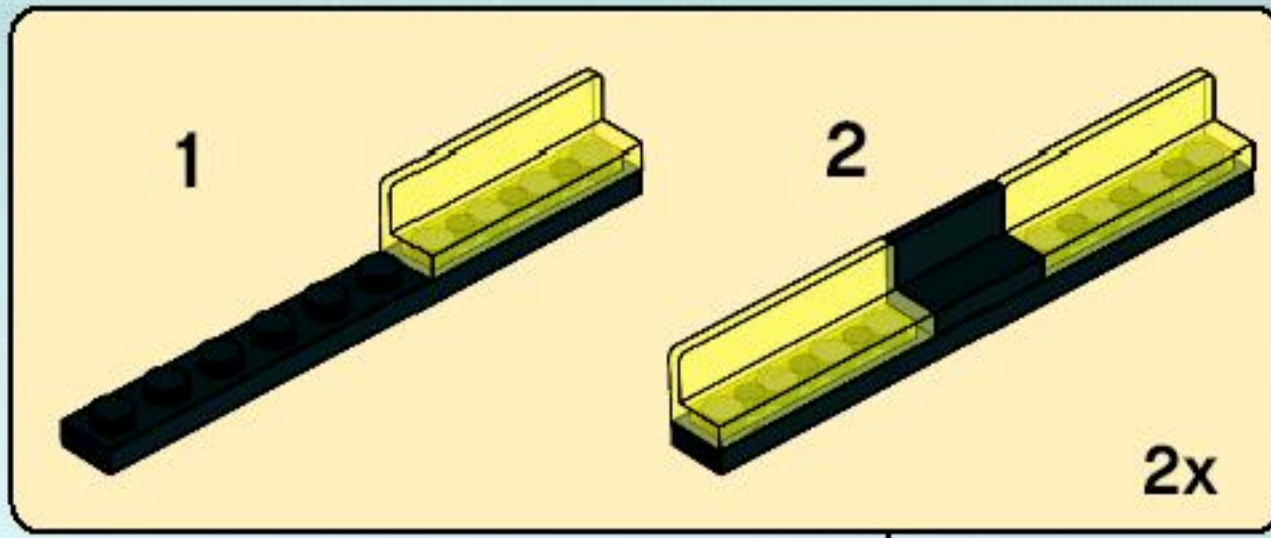
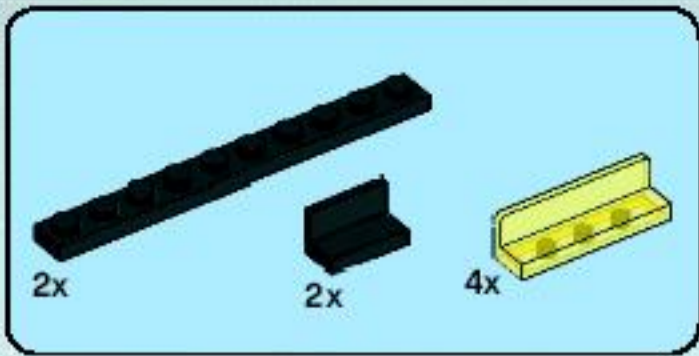

20

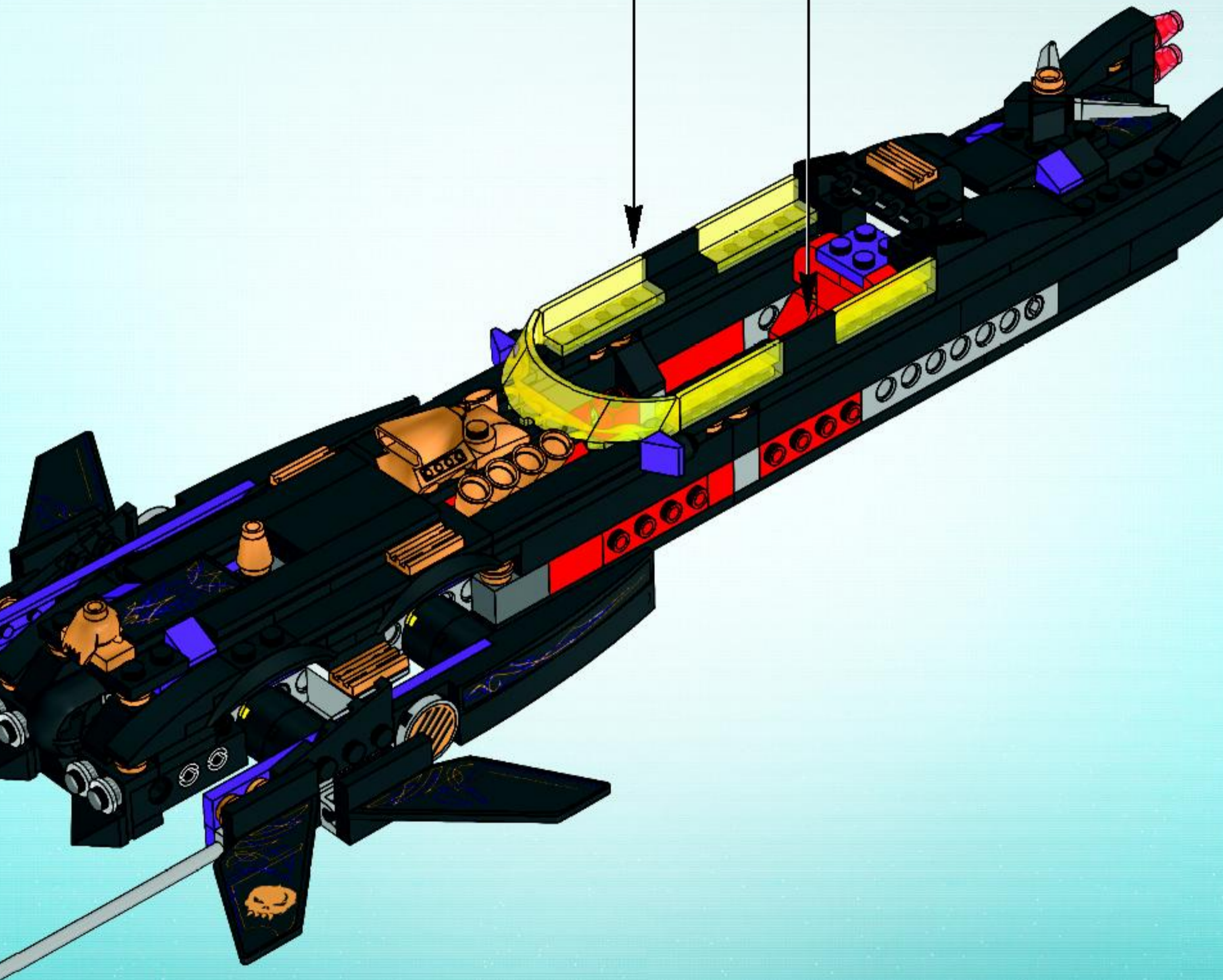

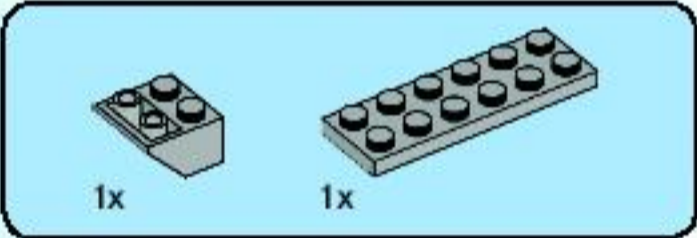
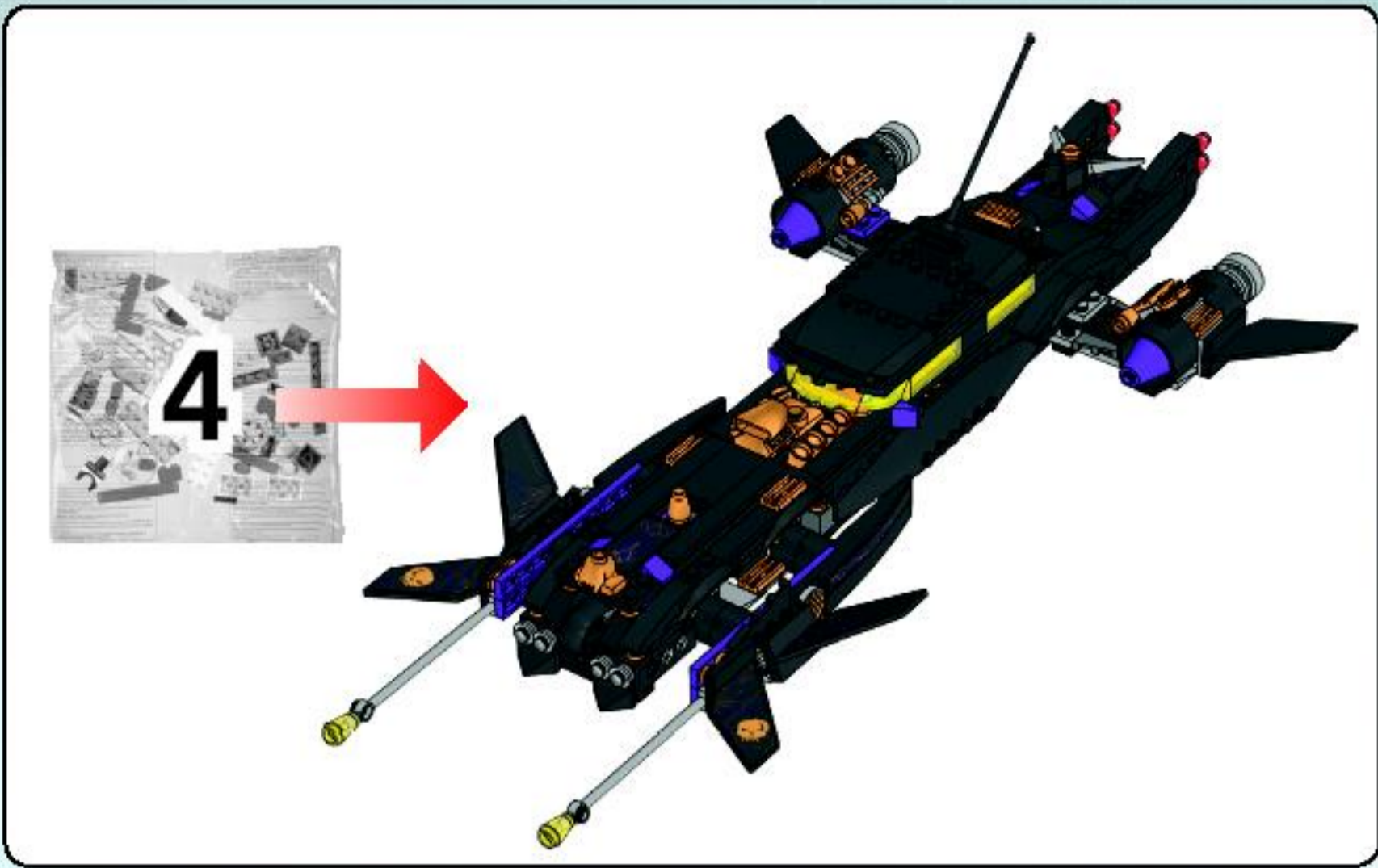

1

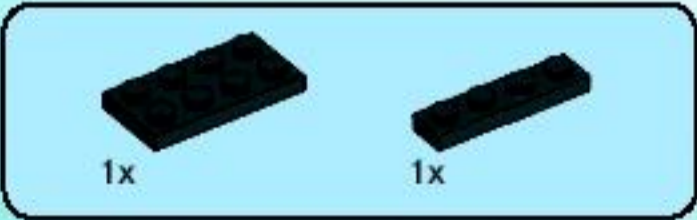
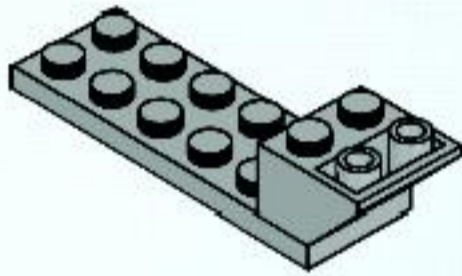

2

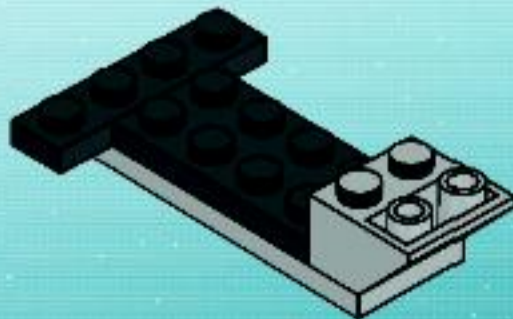

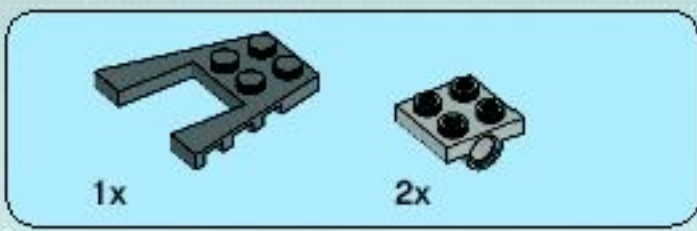

3

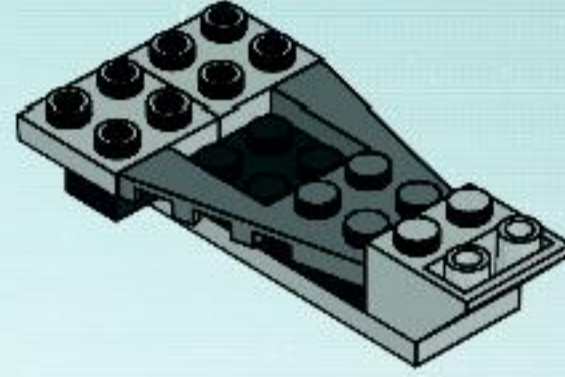

4

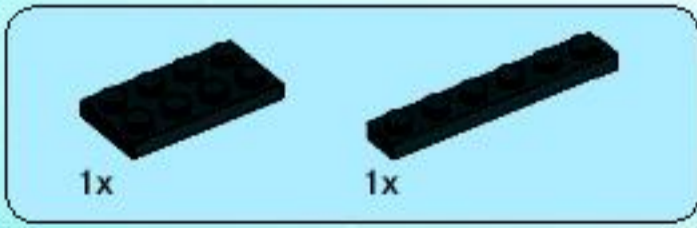
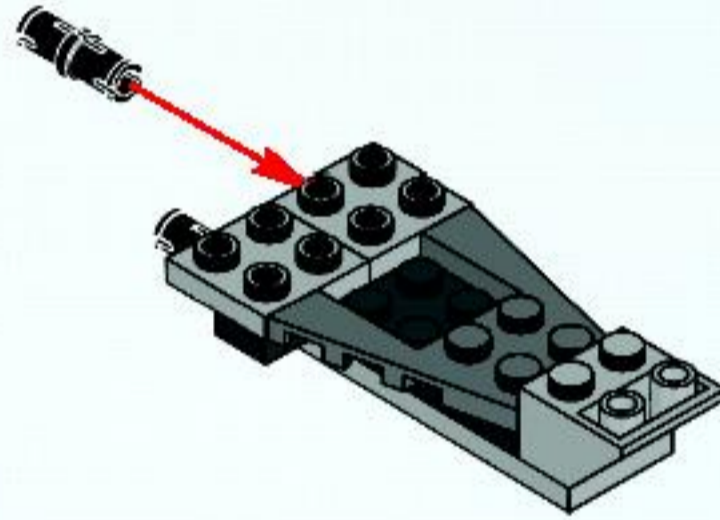

5

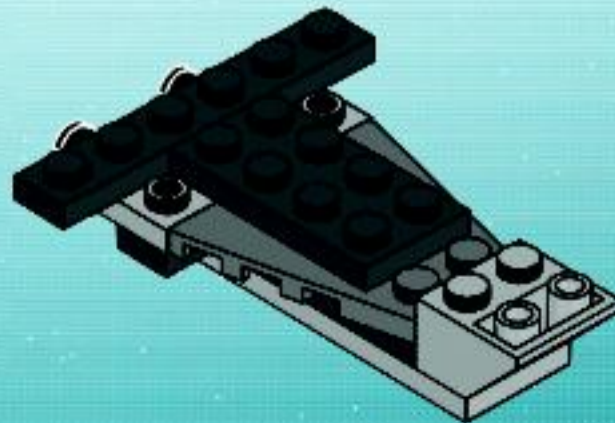



6

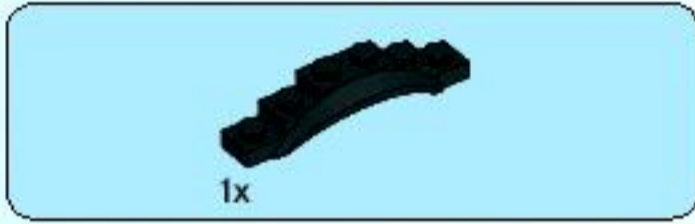
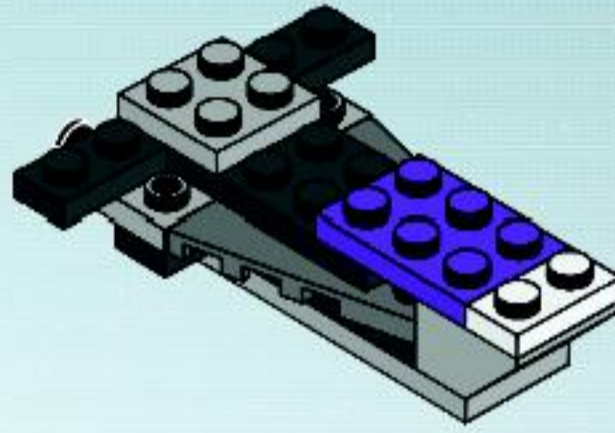

7

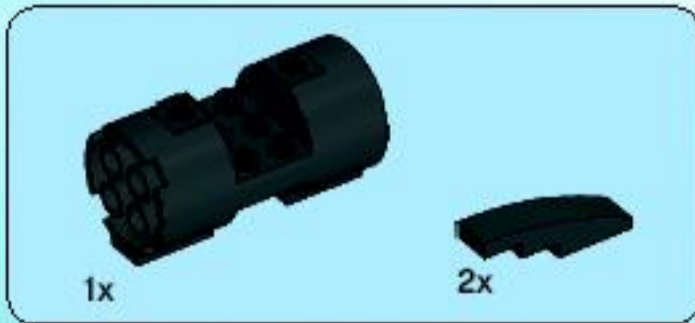
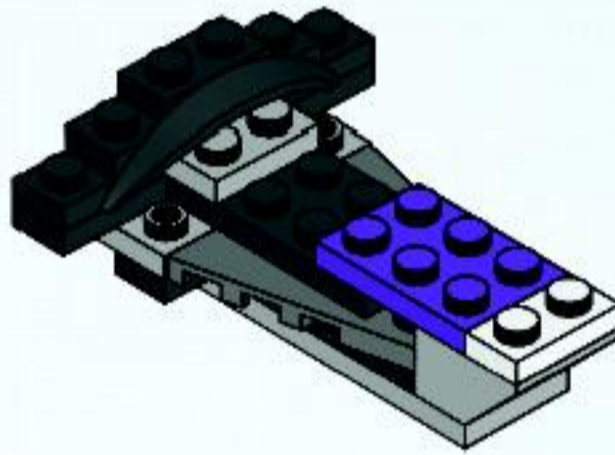

8

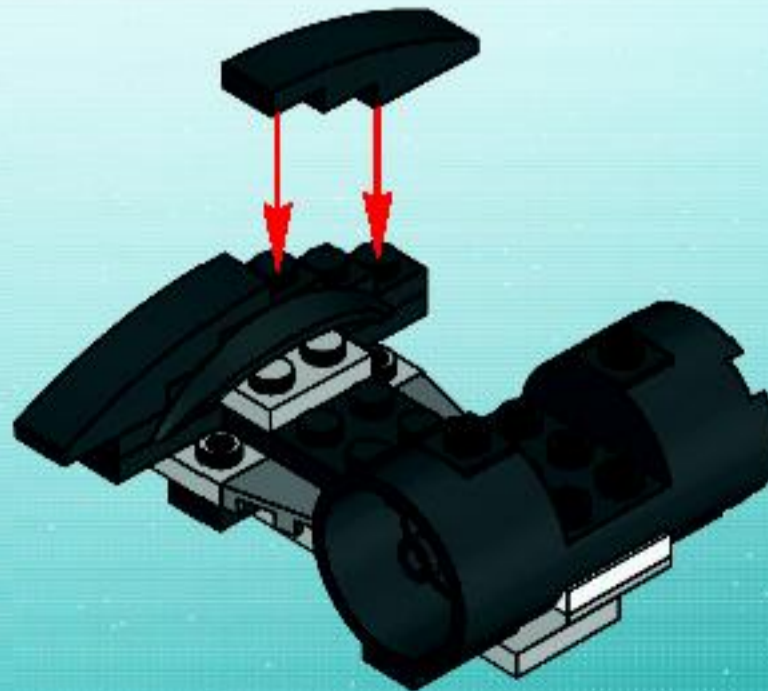



1x

9

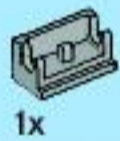
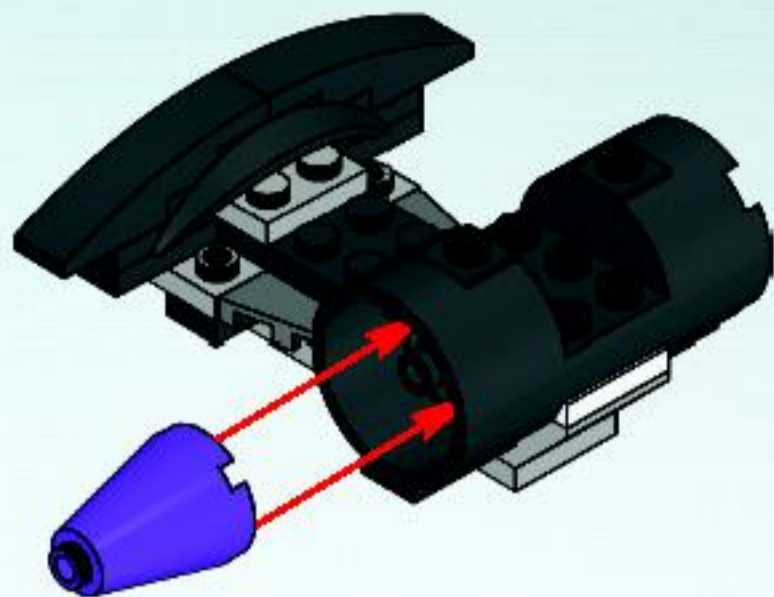

1x



1x

10

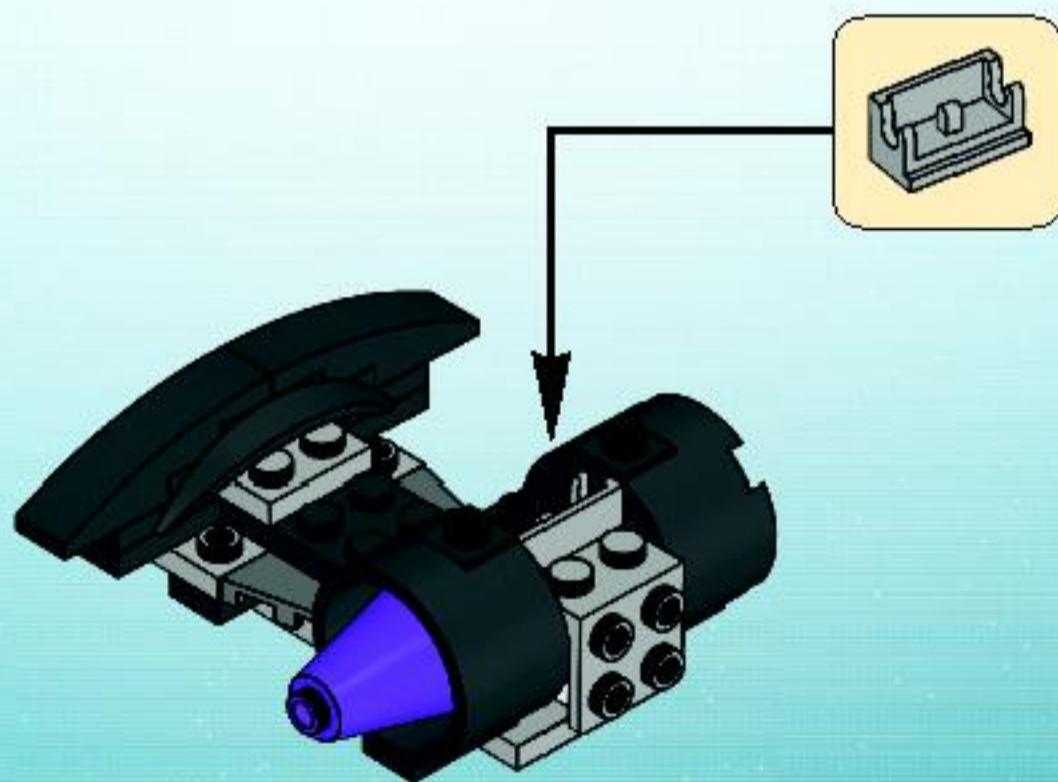

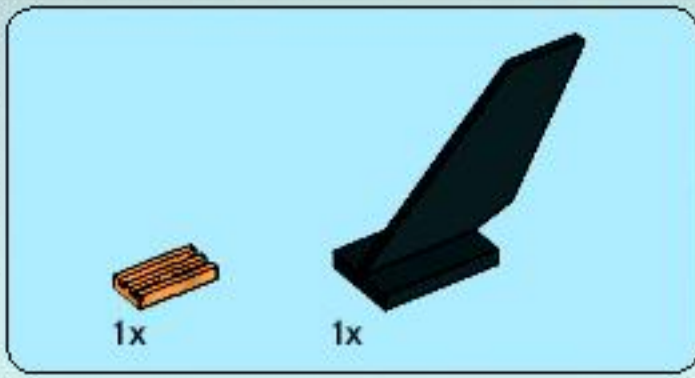

11

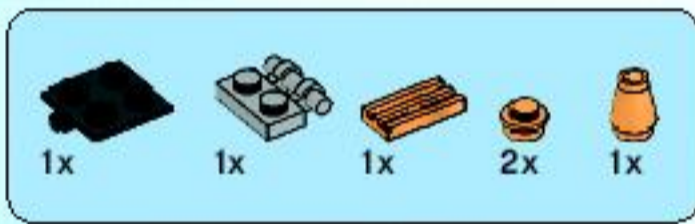
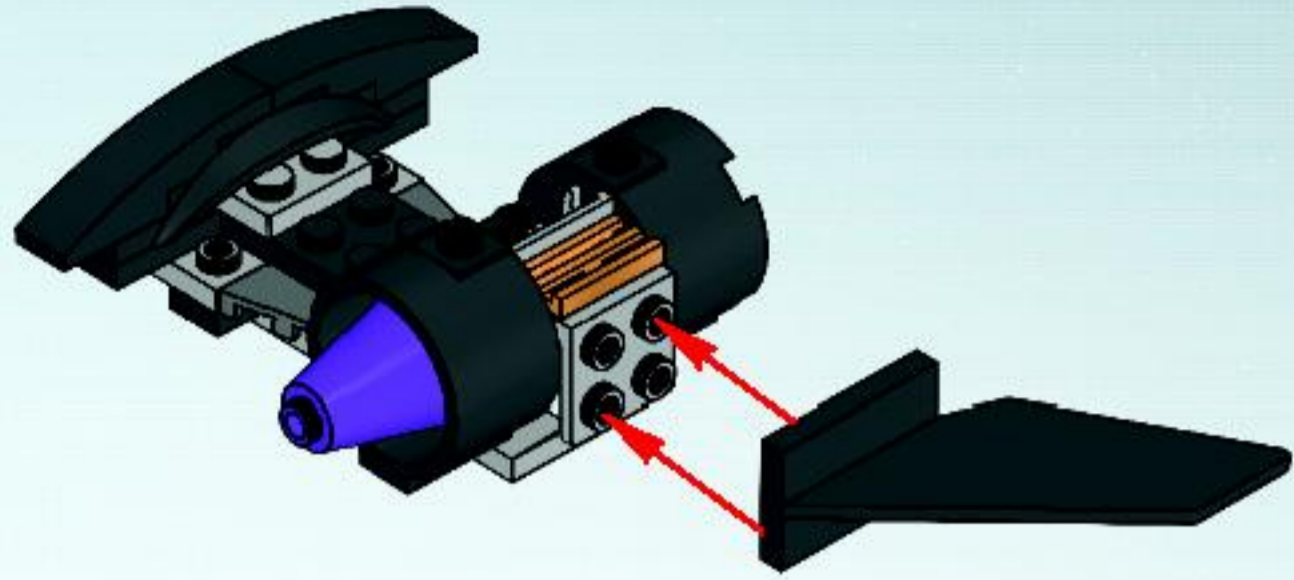

12

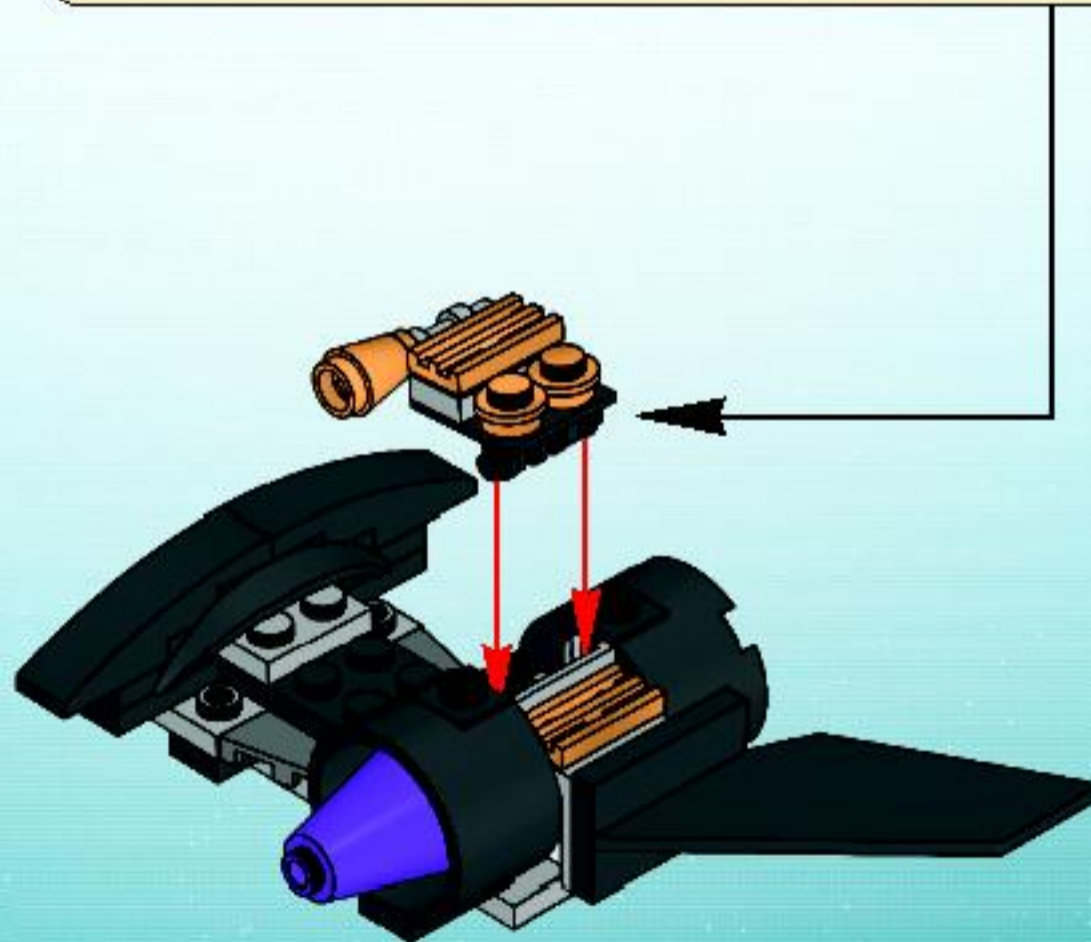



13

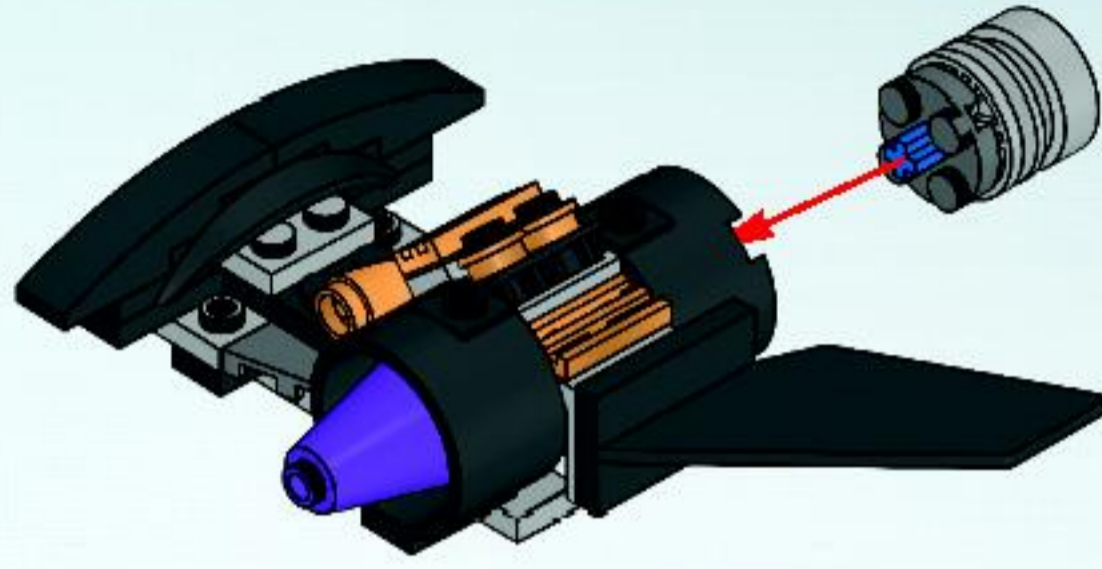
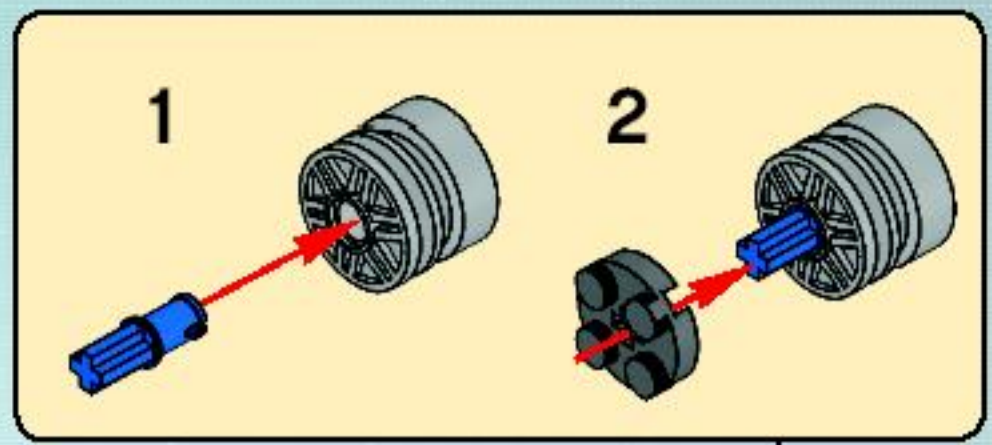

14

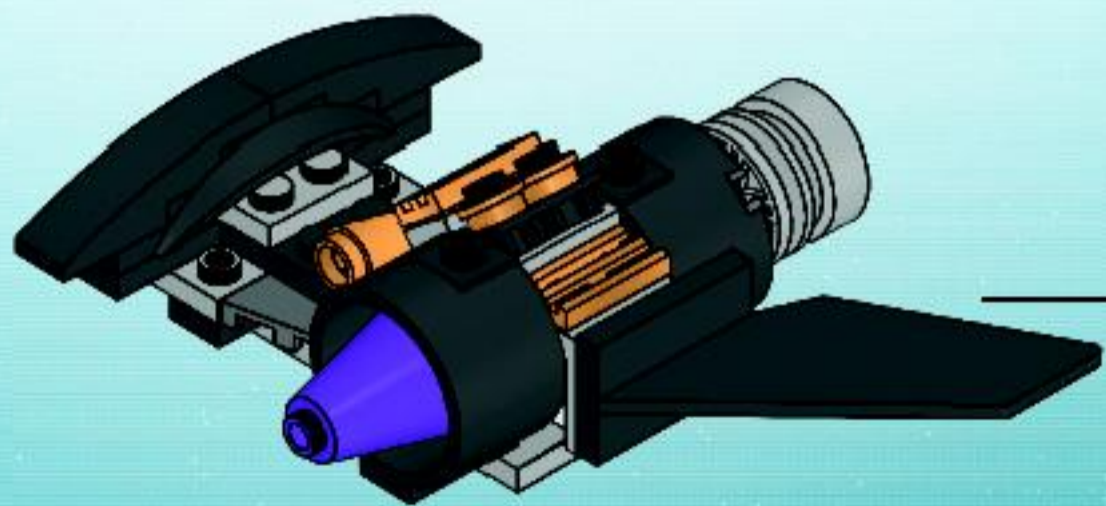

21

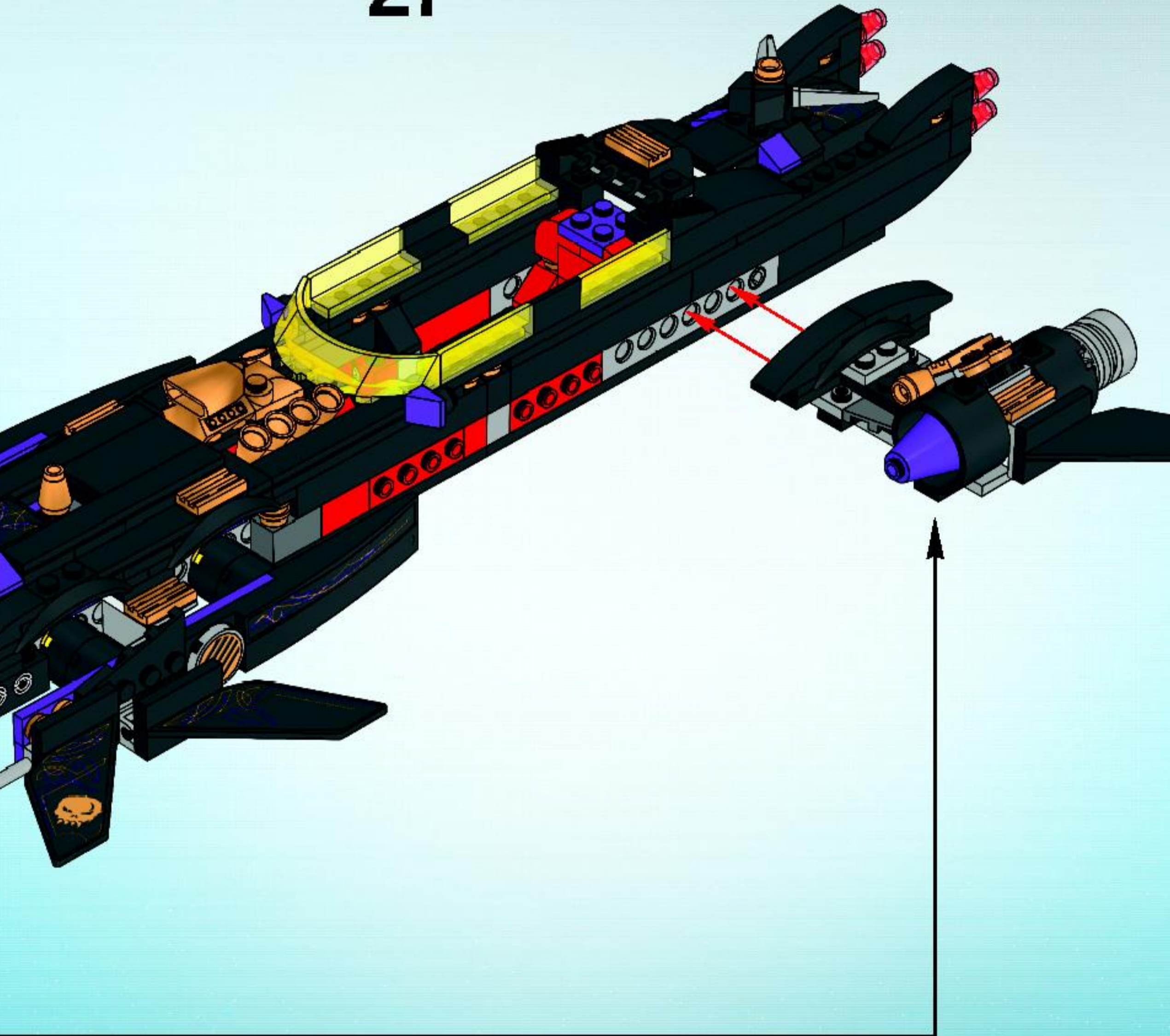



22

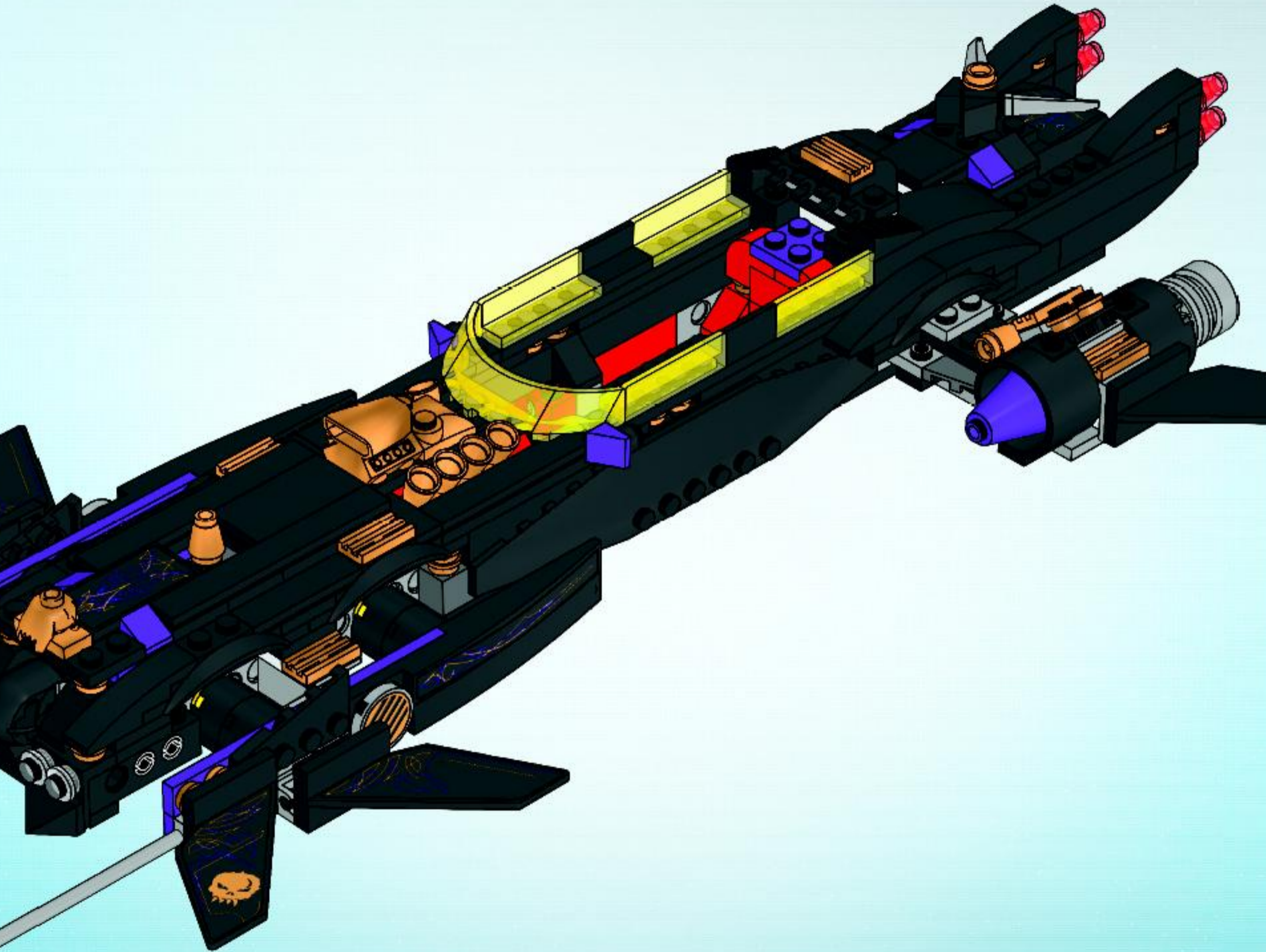

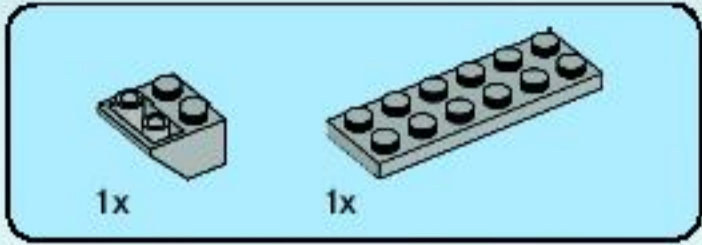
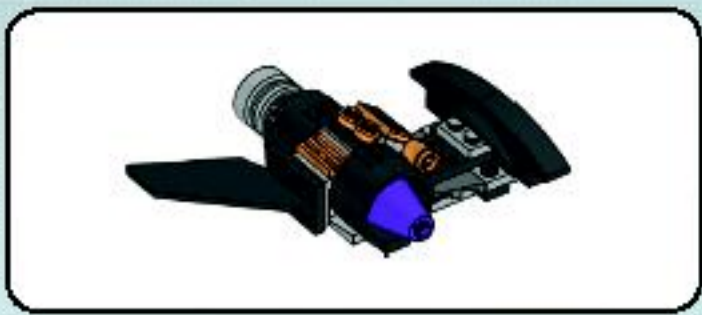

1

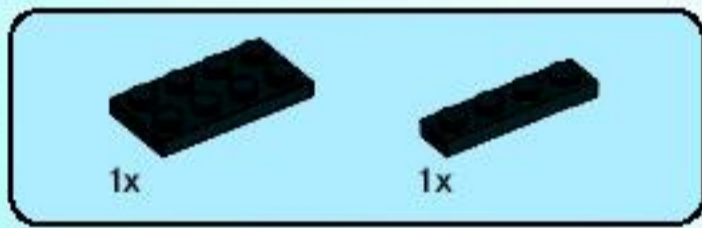
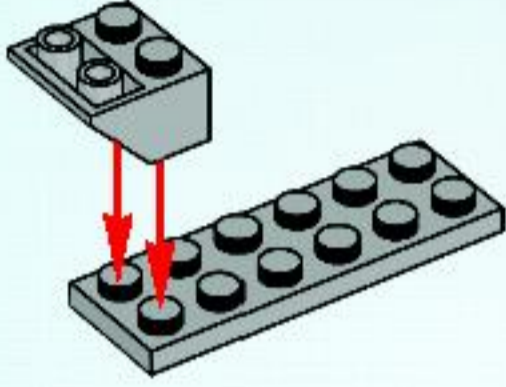

2

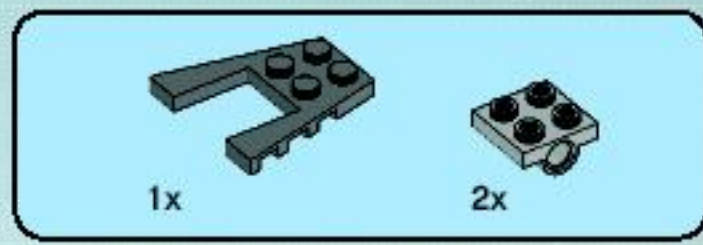
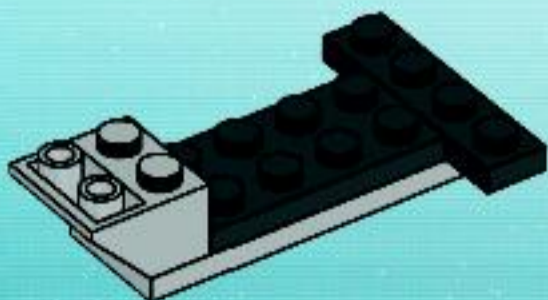

3



4

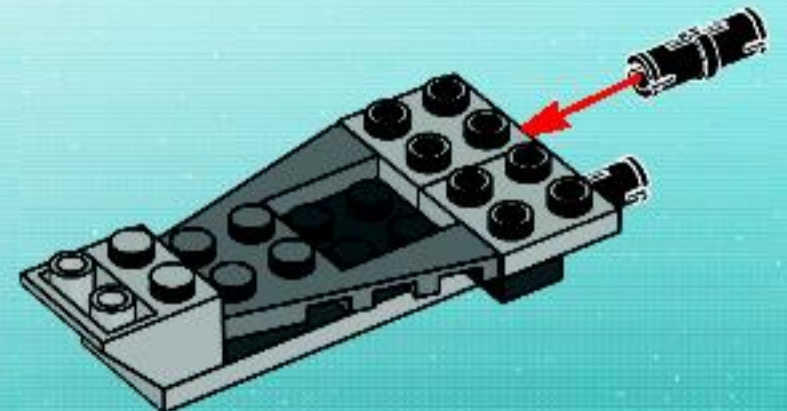

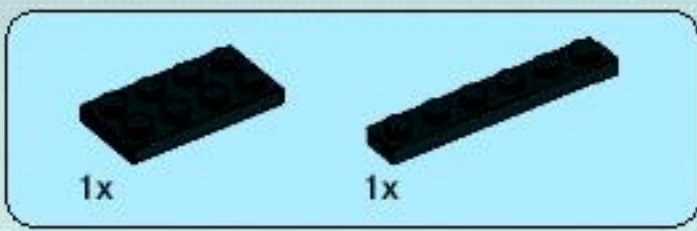

5

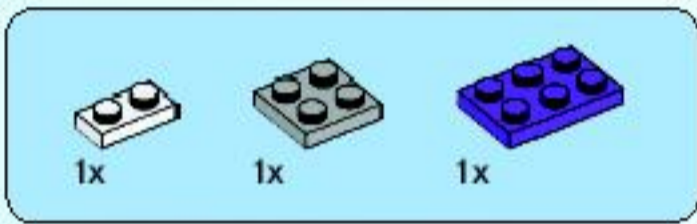
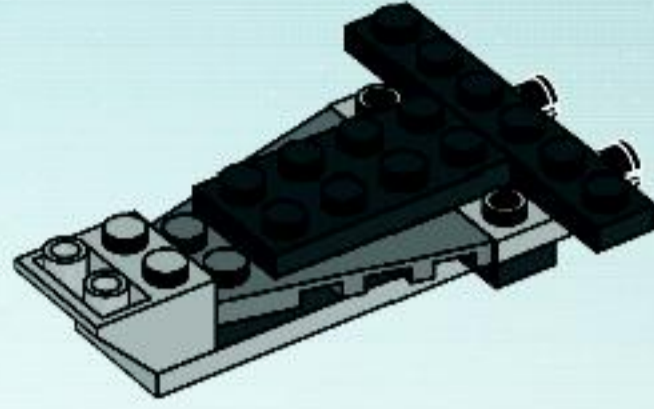

6

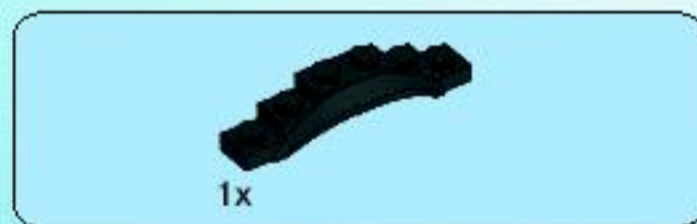
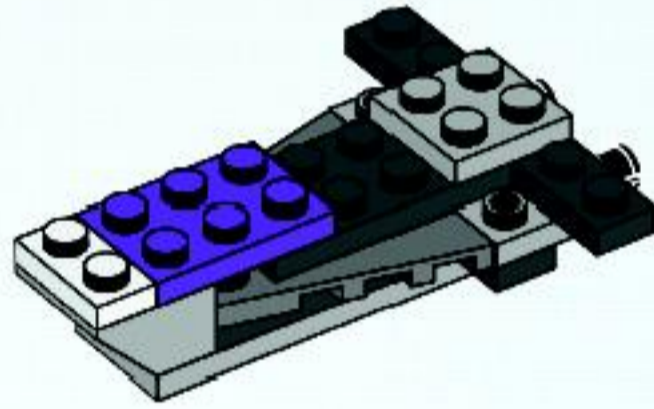

7

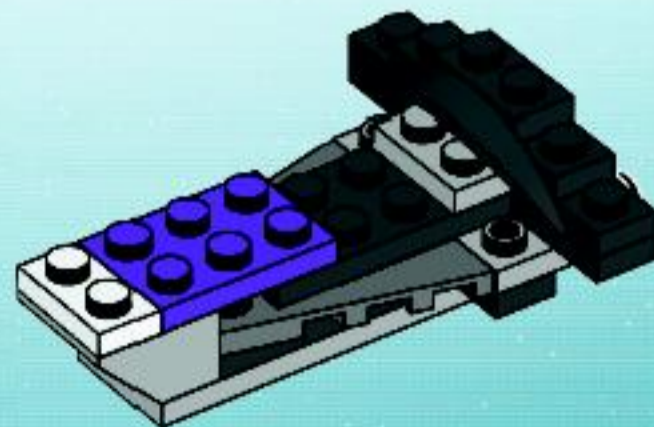

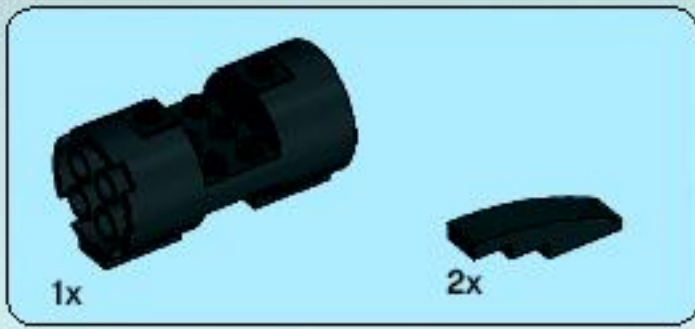

8

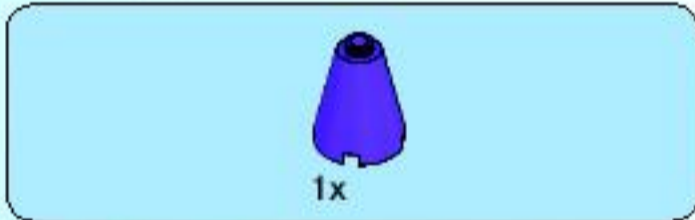
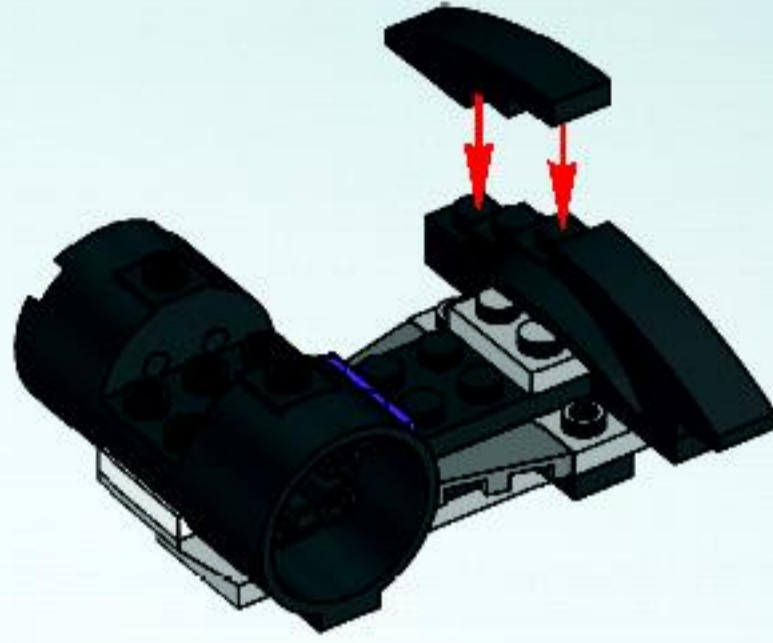

9

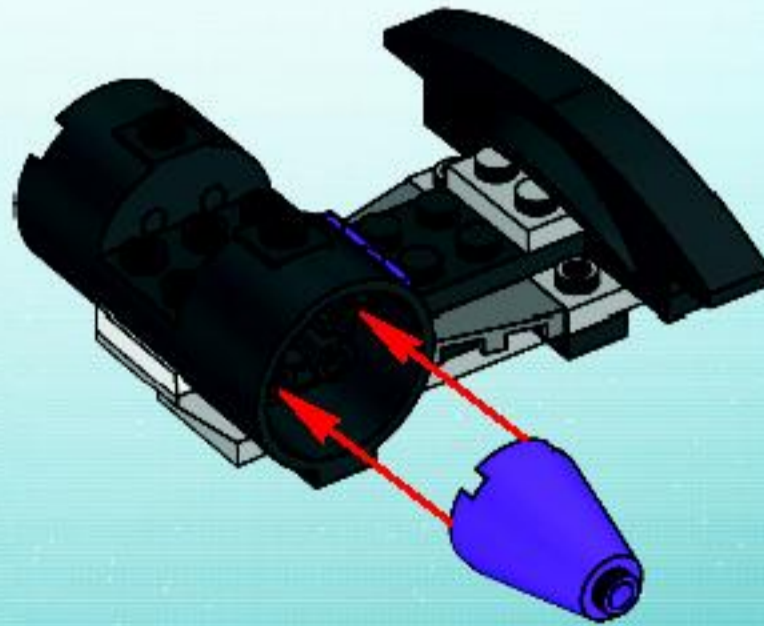

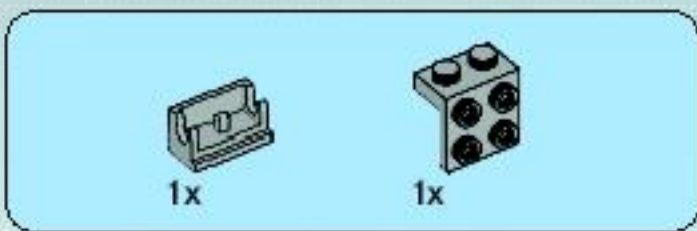

10

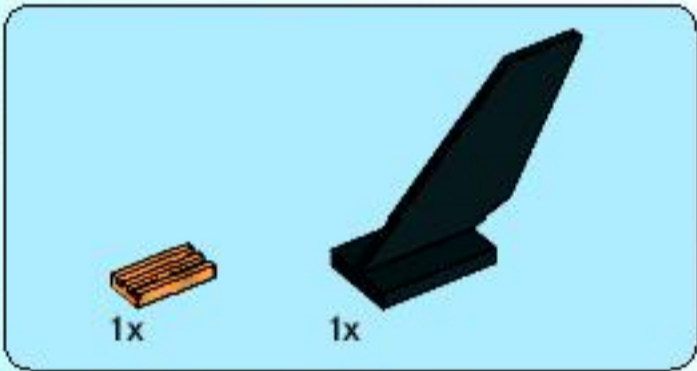
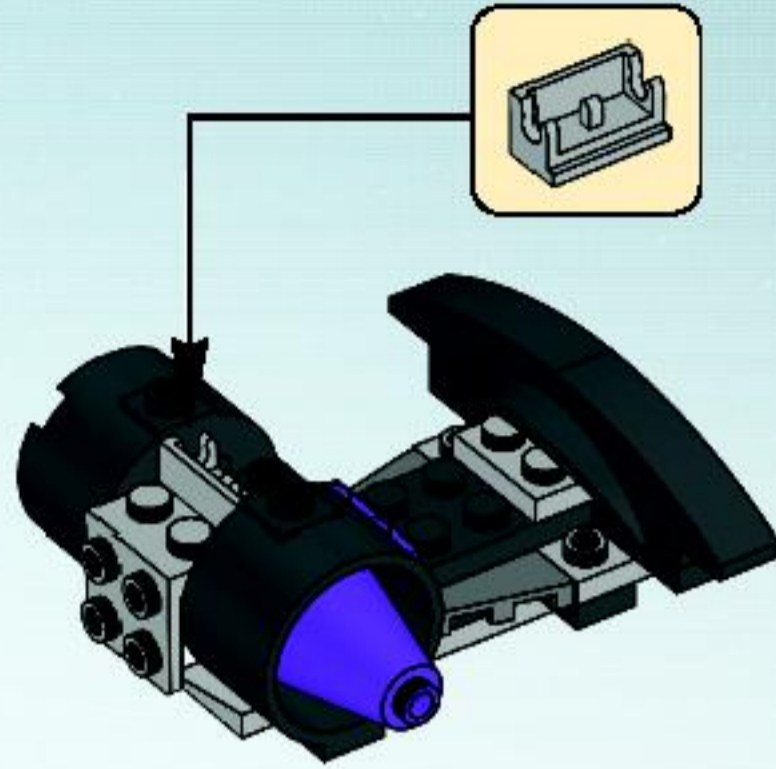

11

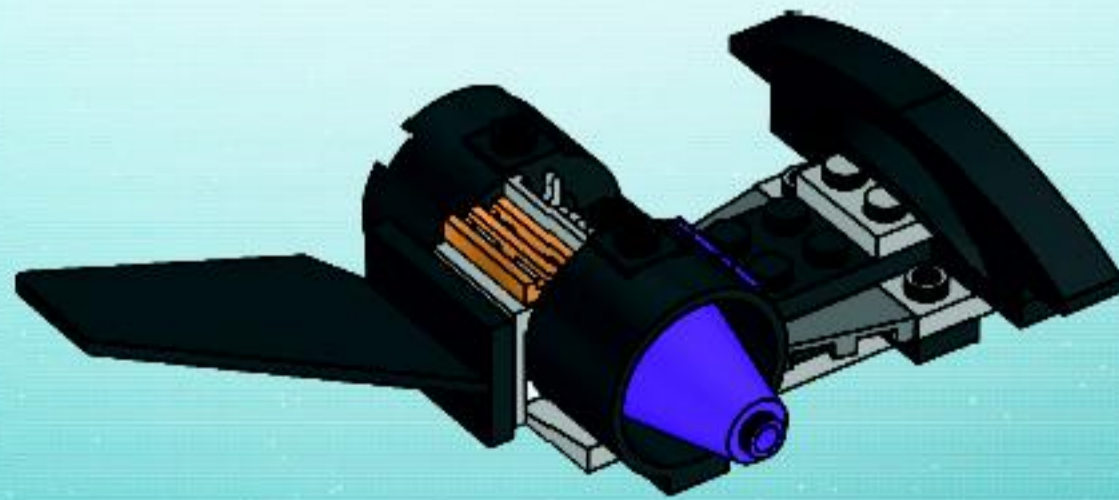

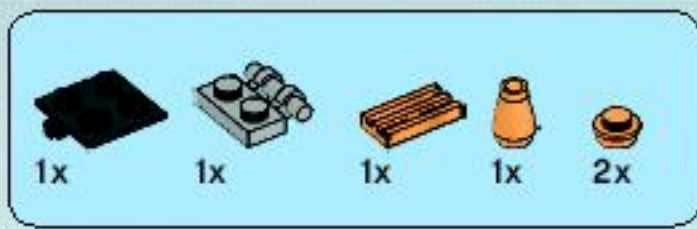

12

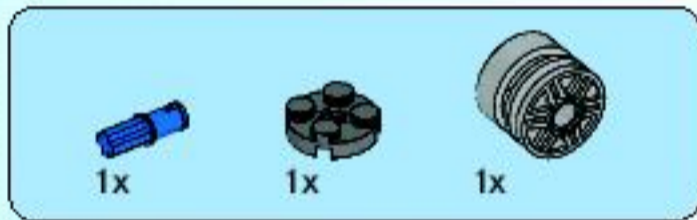
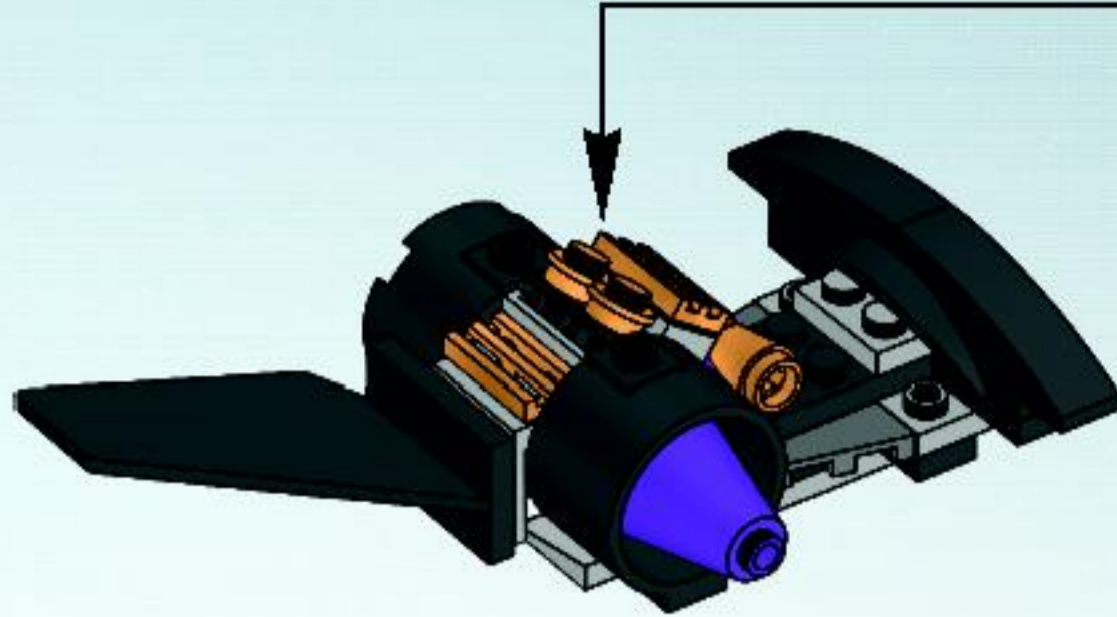

13

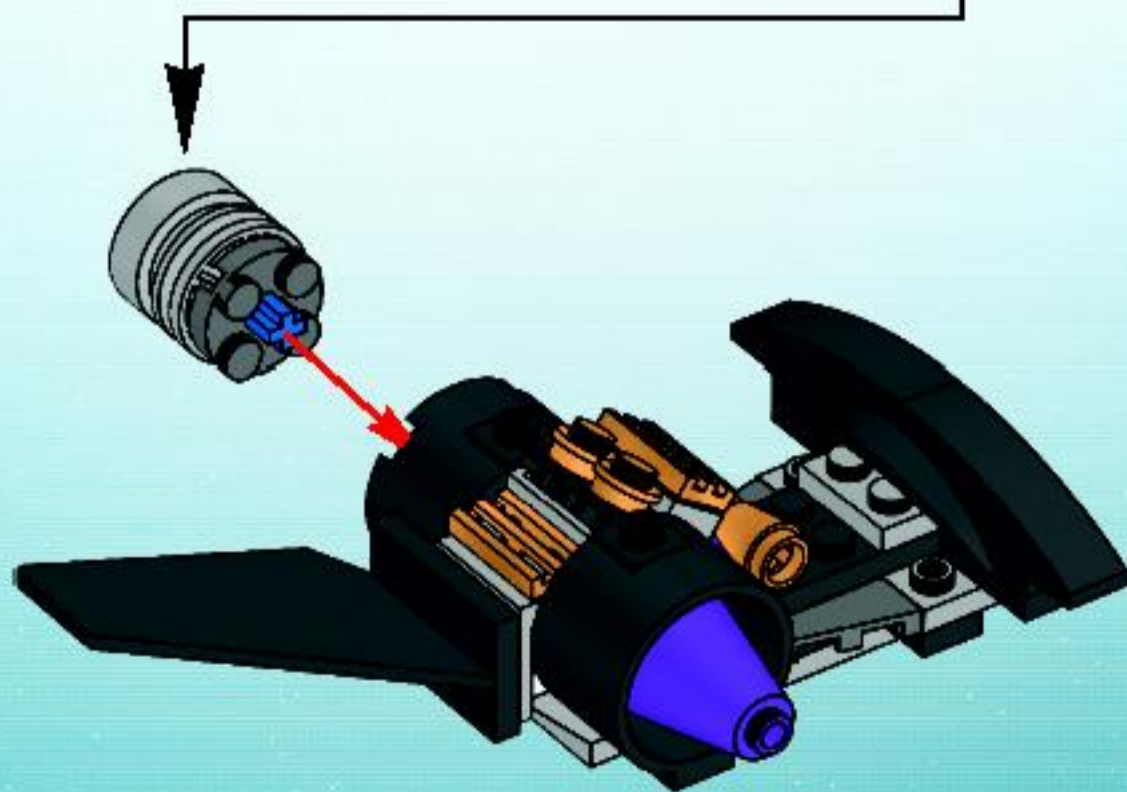
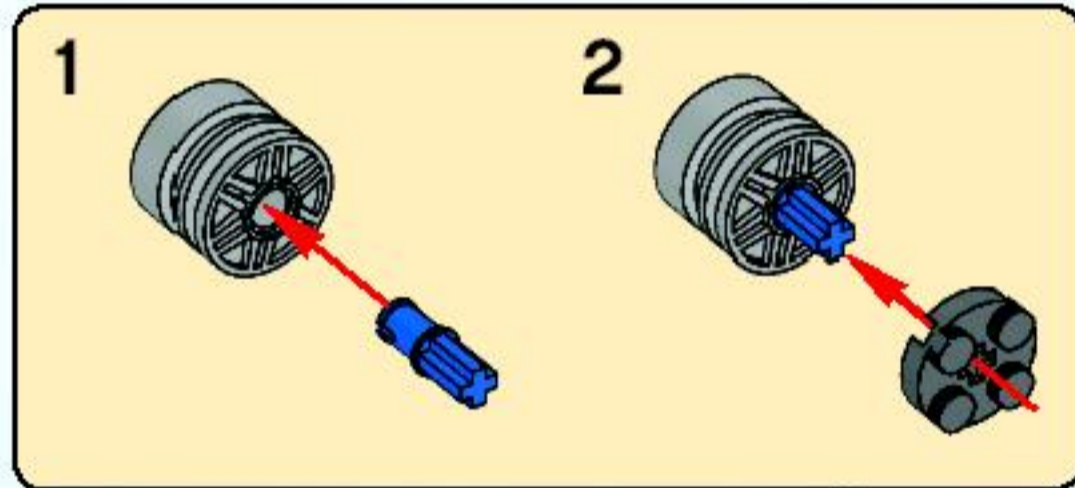

23

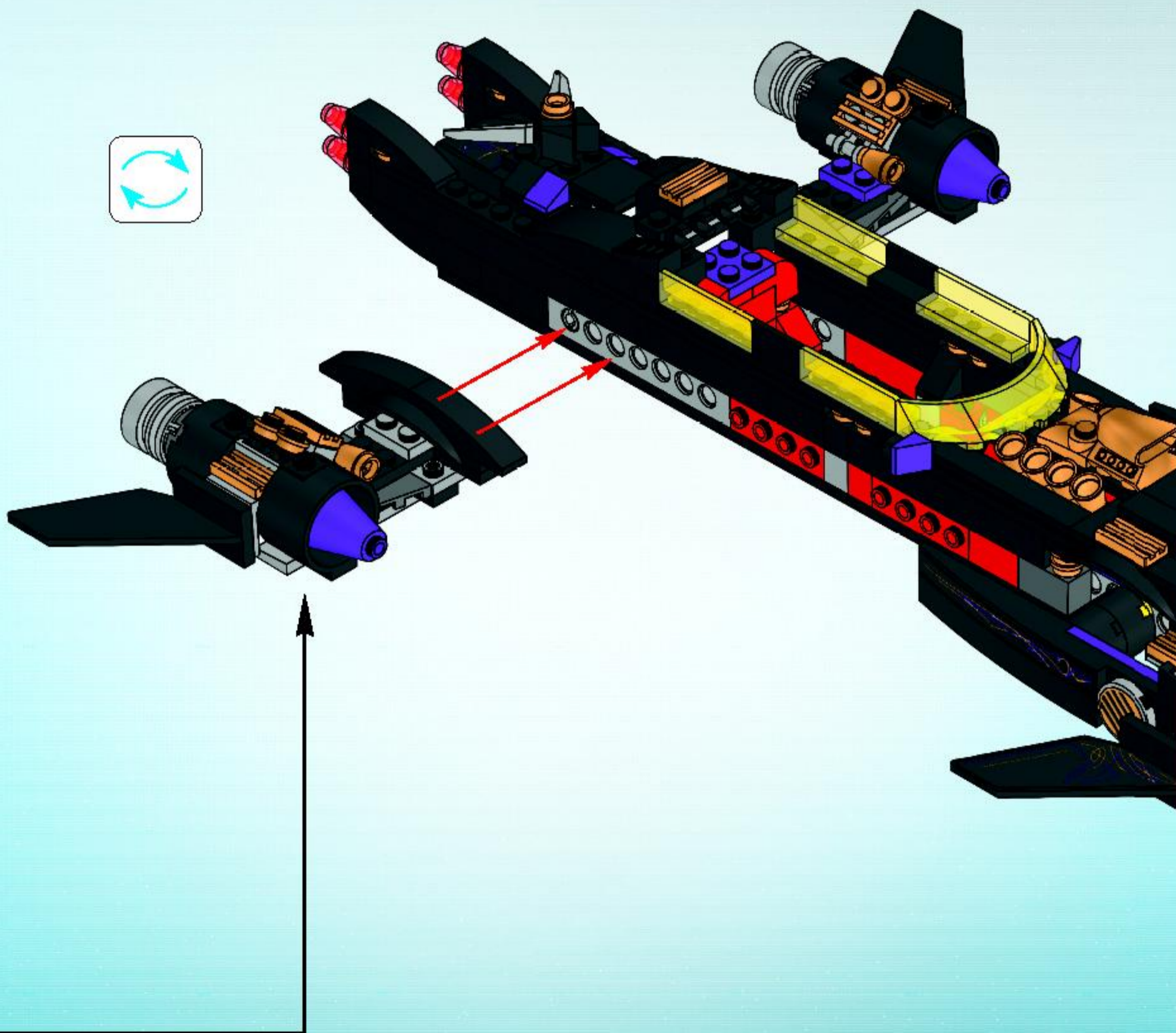

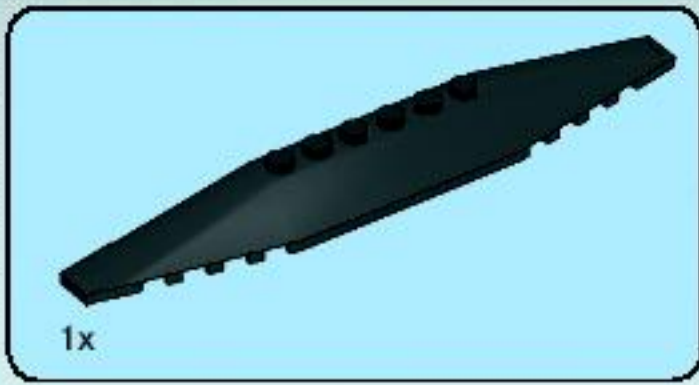

24

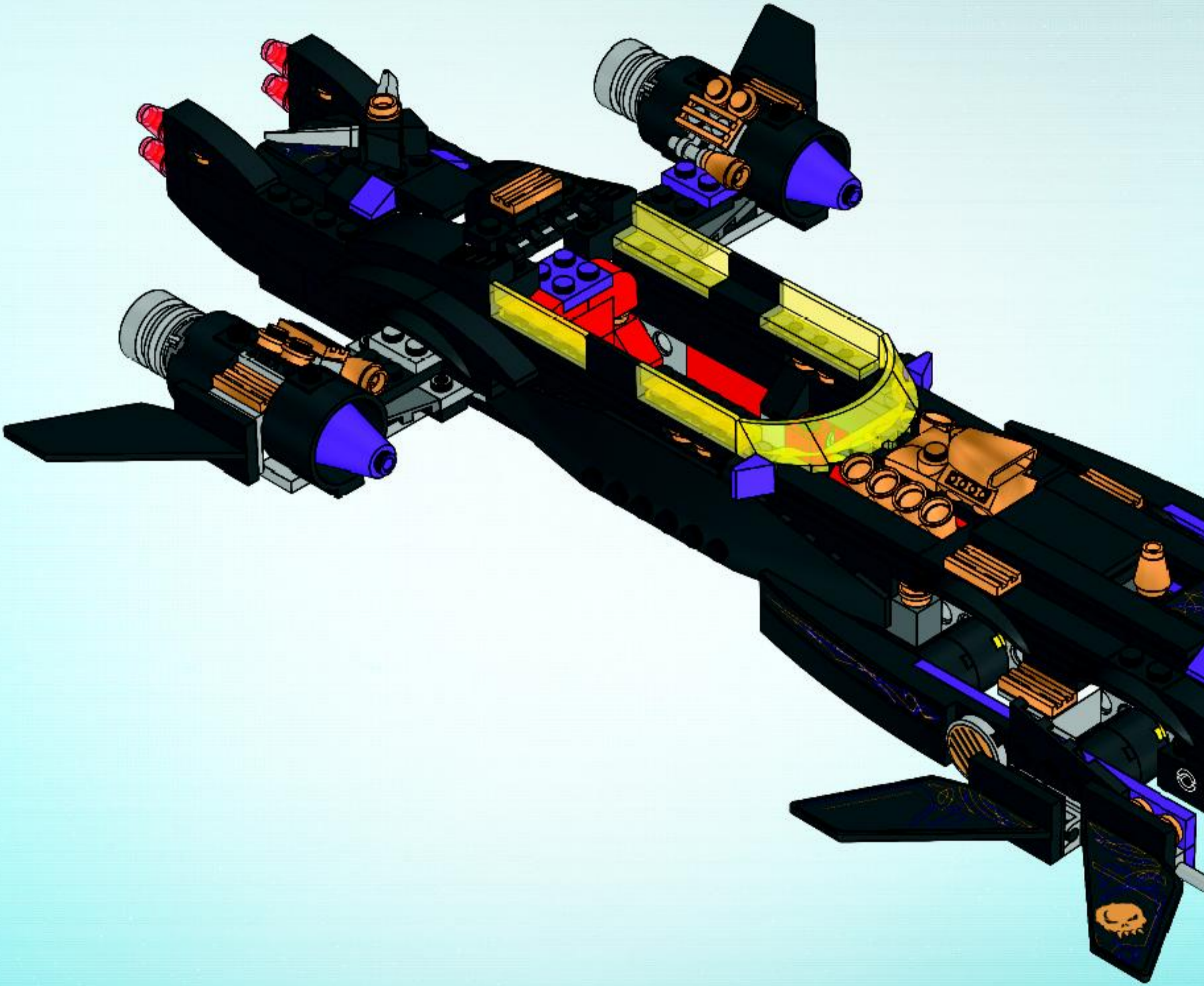

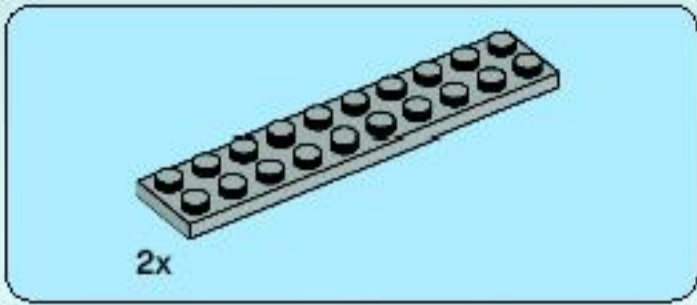

1

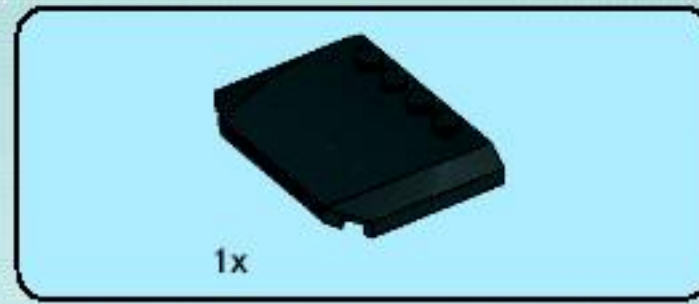
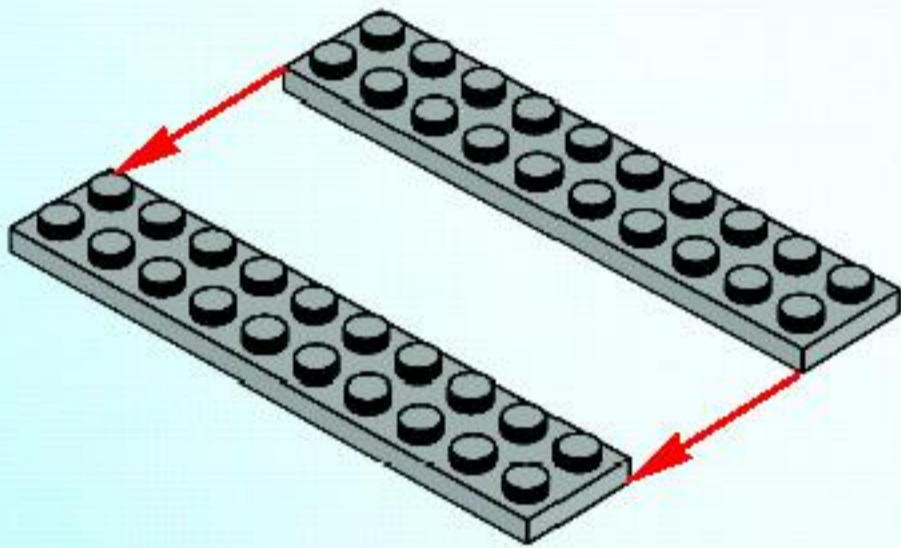

2

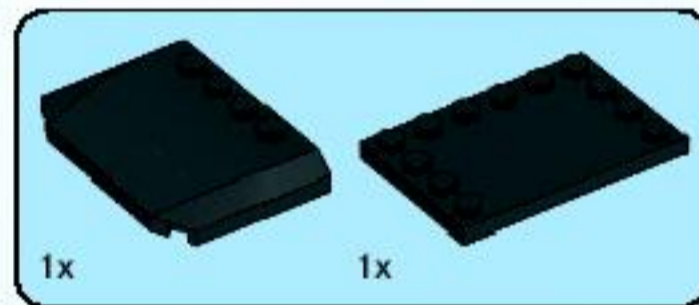
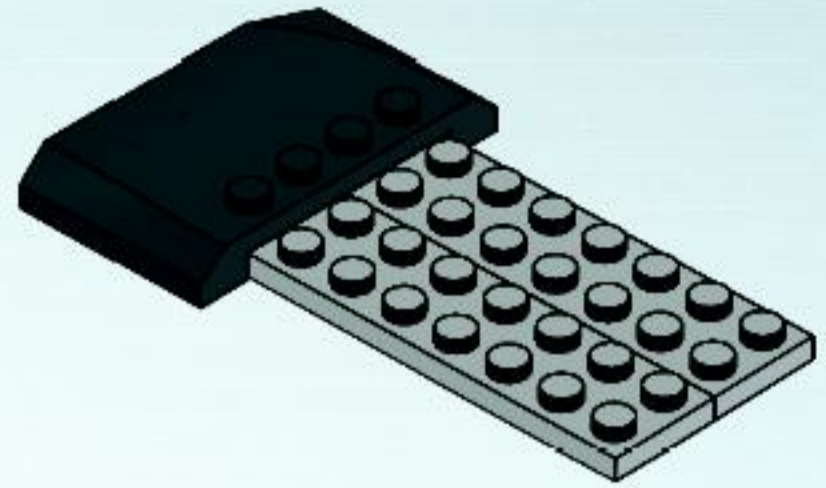

3

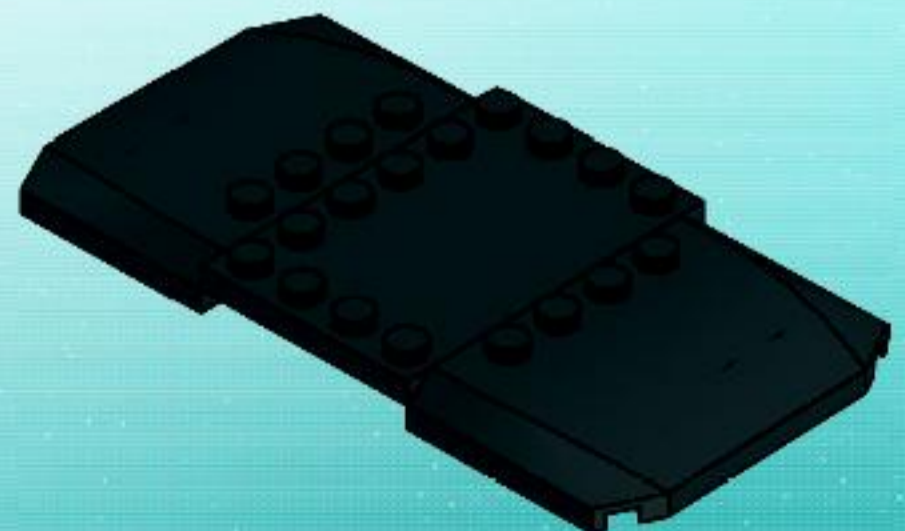

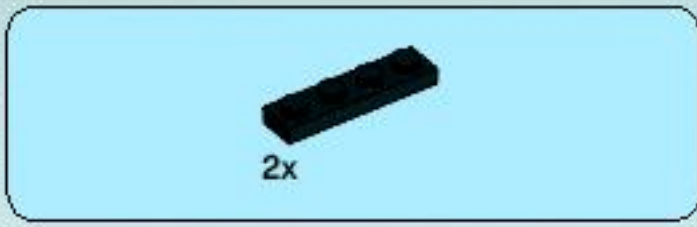

4

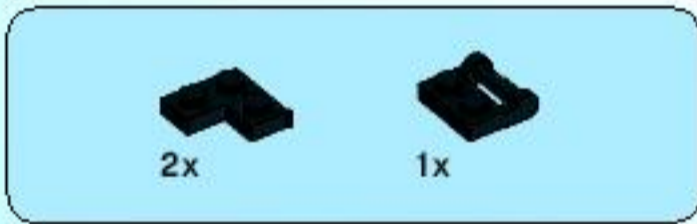
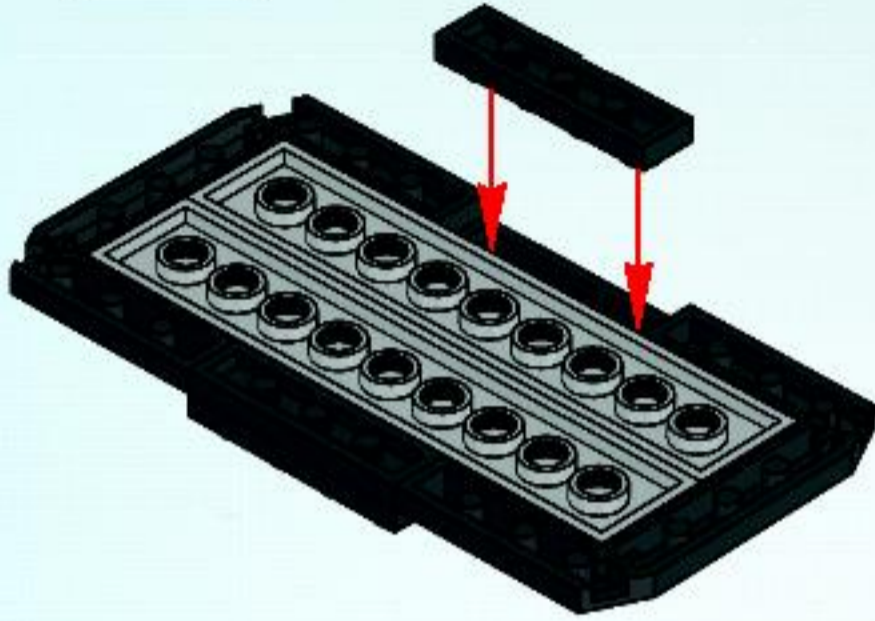

5

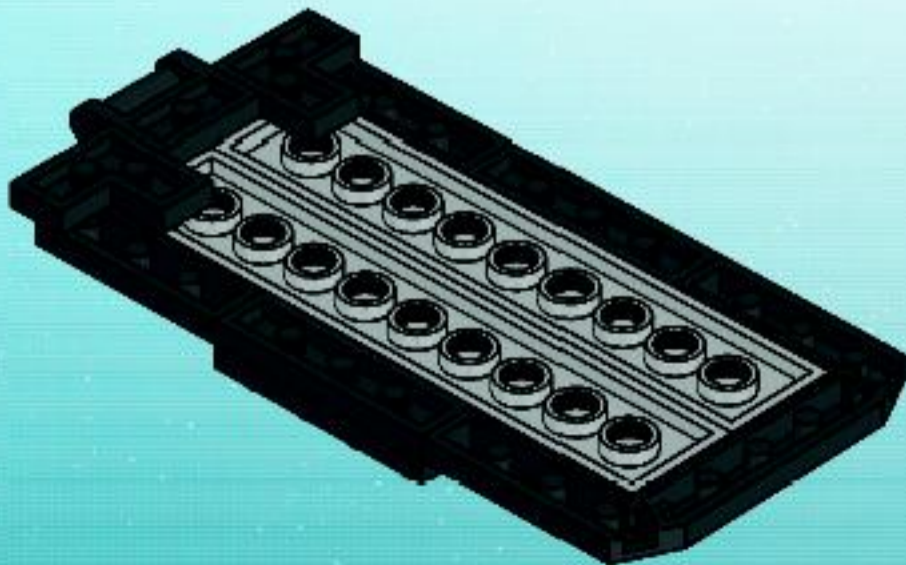

6

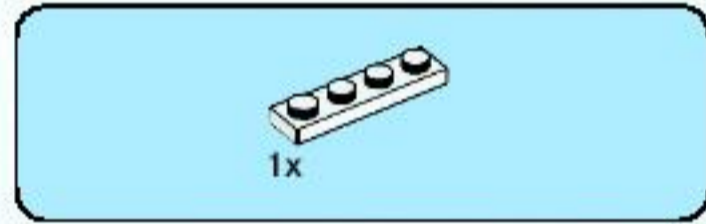
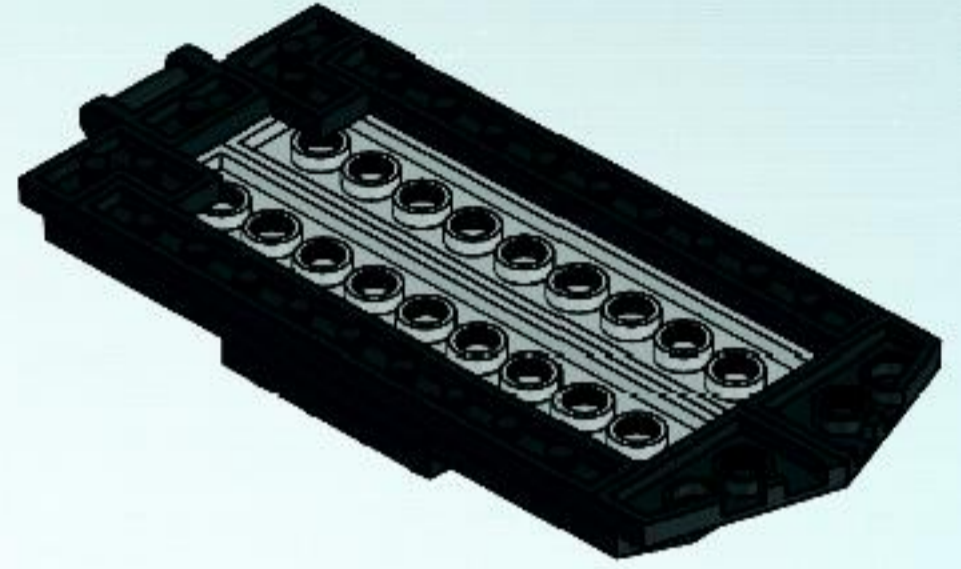

7

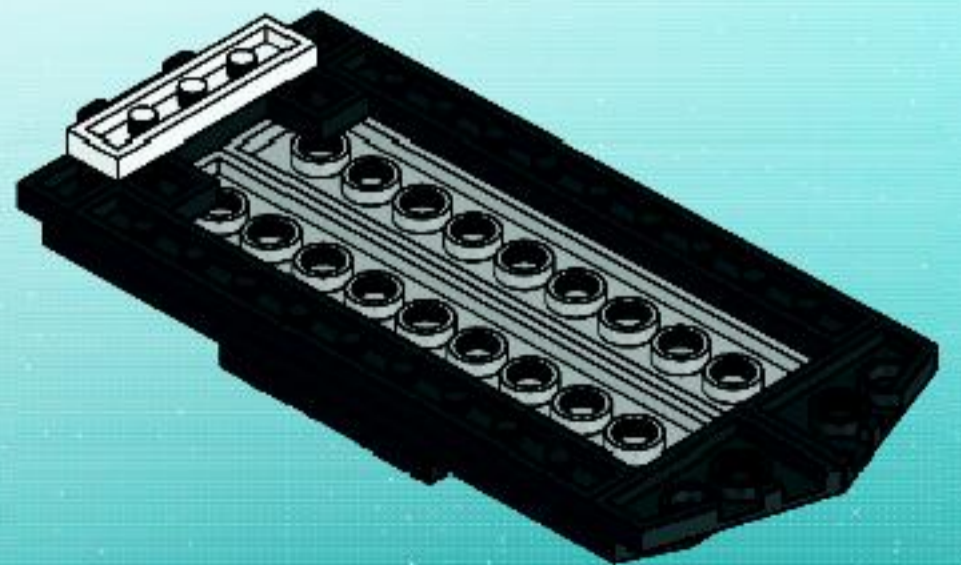

8

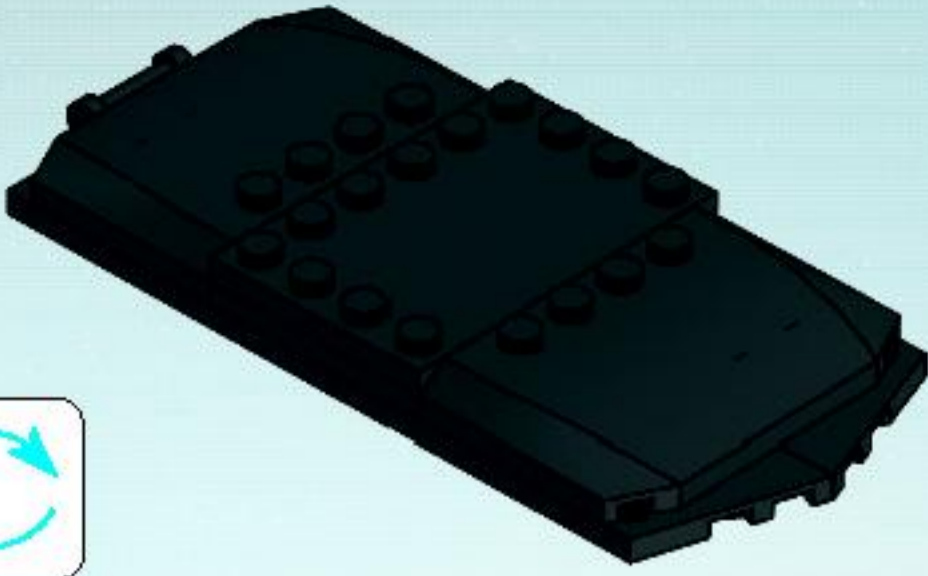

25

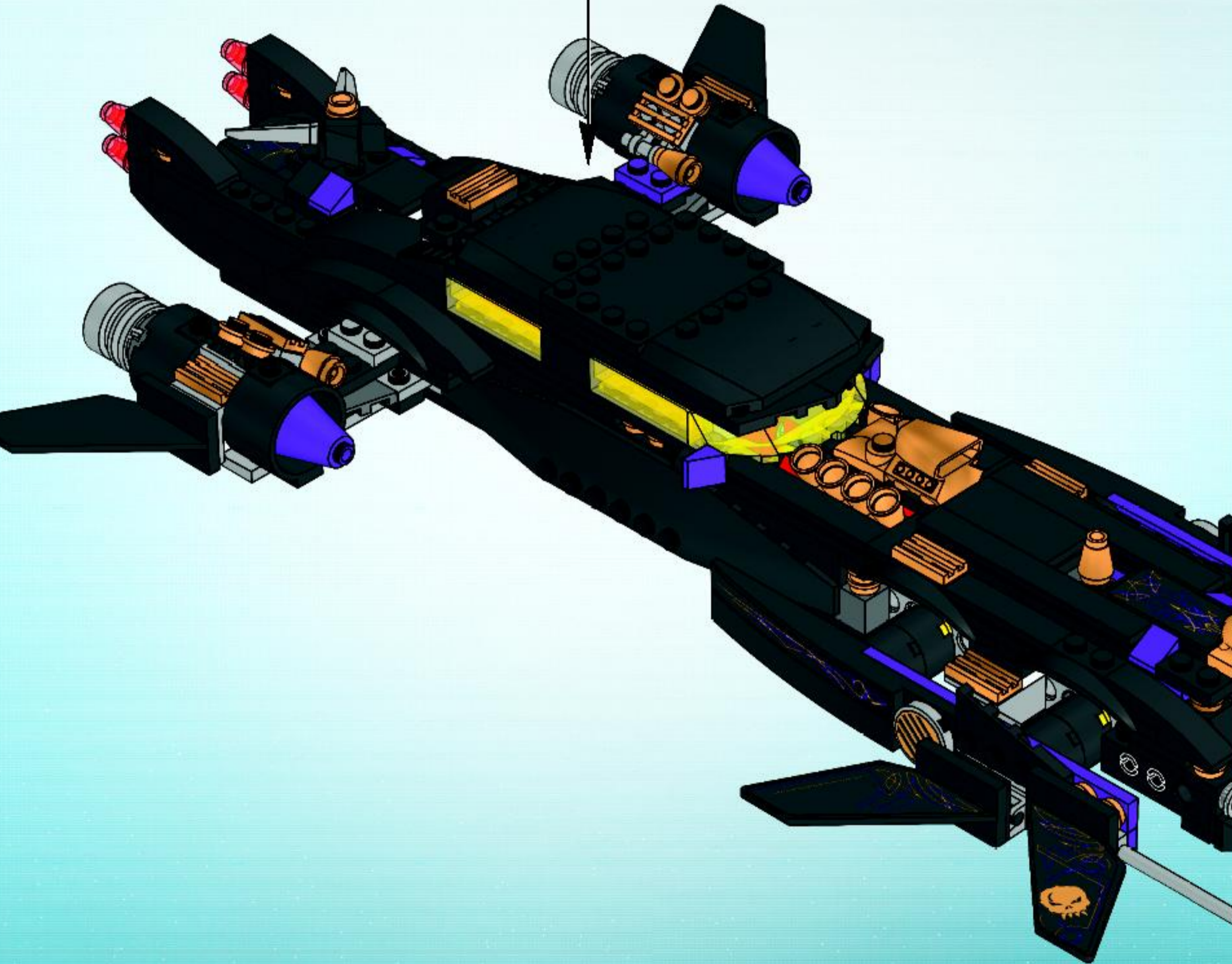



26

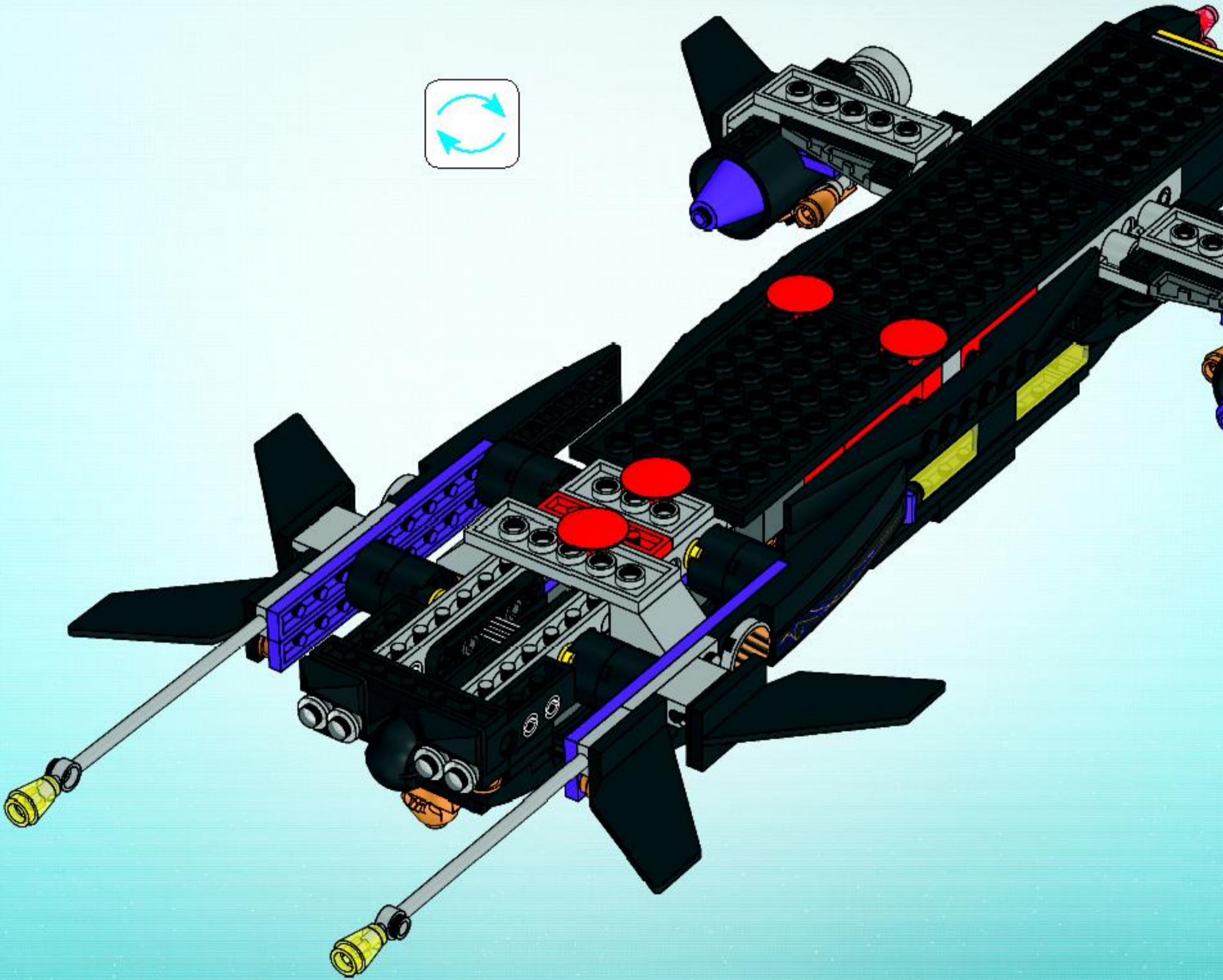



27

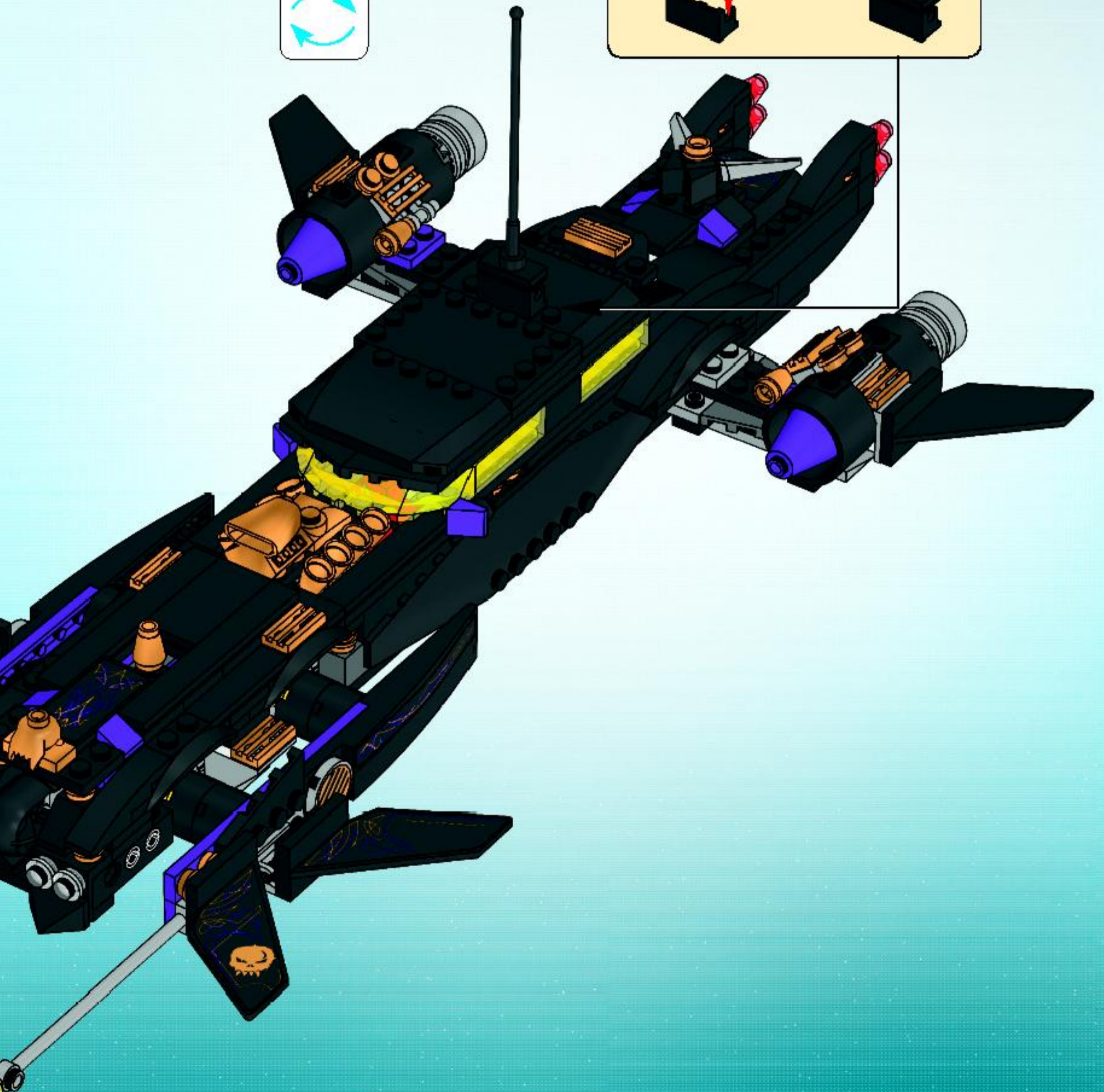
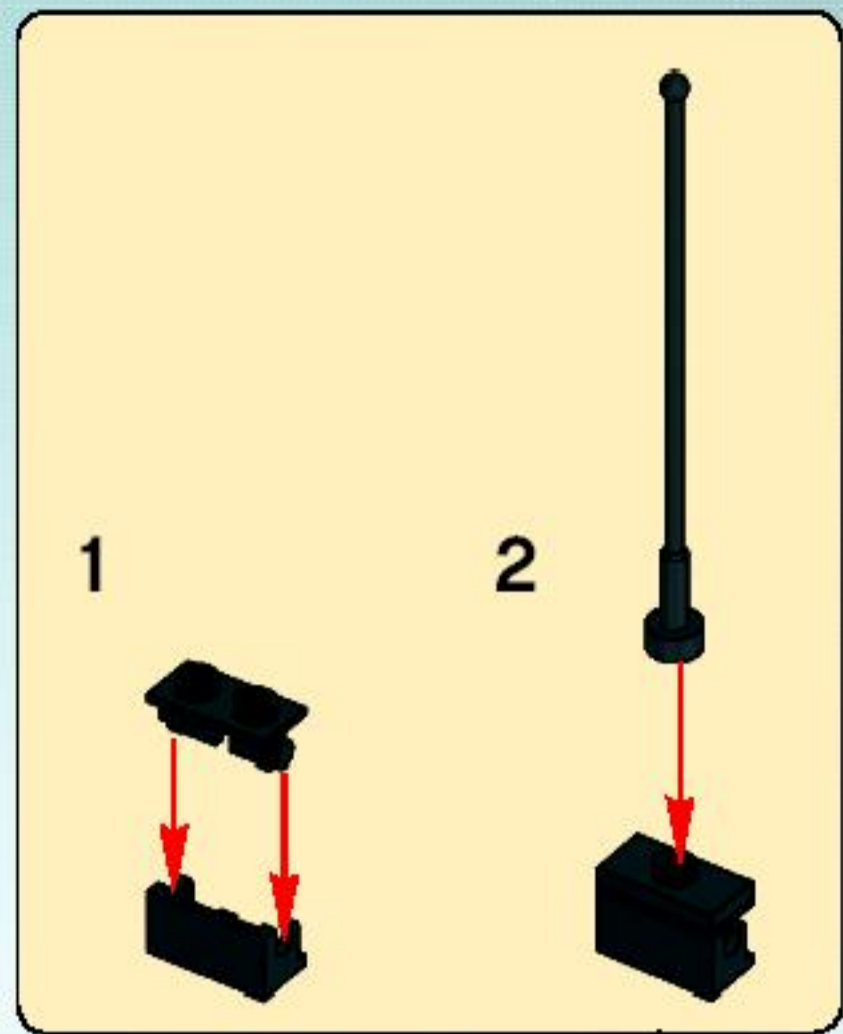
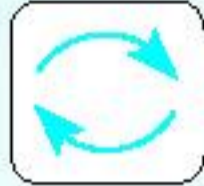





FREE! GRATIS! GRATUIT!



club
MAGAZINE™

www.LEGOclub.com



00800 5346 5555*



1-866-534-6258 • 1-877-518-5346

US & Canada only

Canada seulement

* FreePhone, Mobile charges may apply. * Numéri sans Frais, Les Frais peuvent s'appliquer avec les téléphones cellulaires. * Gebührenfrei, Kosten für Anrufe von Mobilfunknetzen können anfallen. * gratis telefonnummer vooPostcode. * Numéro gratuit, par de régler par Postcode. * De tar gratis, når du ringer fra en Postcode. * De tar gratis, når du ringer fra en Postcode.



**VISIT THE WORLD'S
BIGGEST LEGO® SHOP!**

www.LEGOshop.com

LEGO

SPACE POLICE

5981



5982



5983



5984





5985



0'2"

0'1"

- 6x 302301
- 1x 302201
- 1x 371001
- 1x 302001
- 2x 235721
- 2x 300121
- 4x 4157223
- 3x 370021
- 1x 4195004
- 4x 4121934
- 1x 4251818
- 2x 609121
- 4x 371021
- 4x 4278275
- 2x 4233484
- 1x 243124
- 1x 302024
- 1x 4506812
- 4x 4239601
- 2x 362226

- 4x 300826
- 2x 611226
- 4x 4558954
- 2x 473326
- 1x 4253815
- 8x 614326
- 2x 4547765
- 2x 370126
- 4x 4504382
- 2x 4541191
- 2x 304826
- 6x 4121966
- 2x 4584332
- 2x 609126
- 8x 4522034
- 2x 4160409
- 2x 4180548
- 4x 4567440
- 8x 302326

- 2x 306826
- 3x 302226
- 2x 242026
- 2x 243126
- 4x 371026
- 2x 4560182
- 10x 302026
- 3x 366626
- 3x 663626
- 2x 346026
- 2x 416226
- 1x 4100378
- 8x 447726
- 1x 303626
- 2x 303326
- 1x 379426
- 1x 4569733

- 2x 4277932
- 4x 4556158
- 2x 4225201
- 1x 4184813
- 1x 4180508
- 1x 4161332
- 1x 4180536
- 1x 4160869
- 1x 403226
- 2x 486526
- 1x 256926
- 1x 4550642
- 6x 4531192
- 1x 4191191
- 6x 4547625
- 2x 4542671

- 2x 408126
- 4x 4124096
- 1x 393826
- 1x 393726
- 6x 4121715
- 2x 370726
- 1x 4518409
- 4x 4544720
- 1x 4569898
- 4x 3005740
- 1x 3005748
- 1x 4586113
- 1x 4585877
- 1x 4211394
- 4x 4211364
- 2x 4211442
- 2x 4211705
- 4x 4211436
- 3x 4211445
- 1x 4211395
- 4x 4211452
- 2x 4211462
- 2x 4277927
- 2x 4211632
- 4x 4211359
- 2x 4515369
- 2x 4211759
- 2x 4211480
- 2x 4221775
- 2x 4539187
- 2x 4299119
- 6x 4211469
- 2x 4211470
- 1x 4299625
- 1x 4211398
- 2x 4211397
- 2x 4211088
- 2x 4211107
- 2x 4211042
- 2x 4561036
- 1x 4551179
- 1x 4551188
- 1x 4568359
- 4x 4211051
- 1x 4566028
- 1x 4261908
- 4x 4211050
- 2x 4297454
- 6x 4567509
- 3x 4225142
- 8x 4566532
- 1x 4585647
- 1x 4586410
- 1x 4587043
- 3x 4529247
- 1x 4523160
- 9x 4490599
- 2x 4523157
- 27x 4523159
- 8x 4505990
- 1x 4286597
- 1x 4584031
- 1x 4586584
- 1x 4584753
- 1x 4595276
- 2x 4567332
- 4x 4581795
- 1x 4581798
- 1x 4143005
- 2x 4206482



Customer Service
Kundenservice
Service Consommateurs
Servicio Al Consumidor

www.lego.com/service or dial

: 00800 5346 5555
: 1-800-422-5346



WIN!

Go to www.nielsen.com/LEGO to fill out a survey for a chance to win a cool LEGO® Product. No purchase necessary. Open to all residents where not prohibited.

 www.LEGO.com



www.nielsen.com/LEGO

GEWINNE!

Nimm an der Umfrage auf www.nielsen.com/LEGO teil und hab die Chance ein cooles LEGO® Produkt zu gewinnen!

Die Teilnahme am Gewinnspiel führt zu keinerlei Kaufverpflichtungen. Teilnahme in allen nicht ausgeschlossenen Ländern möglich.

WIN!

Ga naar www.nielsen.com/LEGO, vul een enquêteformulier in en maak kans op een cool LEGO® product.

Geen aankoopverplichting. Iedereen mag deelnemen, uitgezonderd ingezeten den van landen waar een enquêteverbod geldt.

GAGNE!

Visite www.nielsen.com/LEGO pour répondre à un questionnaire et avoir une chance de gagner un produit LEGO® très cool!

Aucune obligation d'achat. Ouvert à tous les résidents des pays autorisés.

当てよう!

www.nielsen.com/LEGOにアクセスして、アンケートにご記入ください。当選者にはレゴ製品を差し上げます。

お買い上げの必要はありません。禁止されていない限り、すべての情報にご利用いただけます。